



# SC 410 2.0

BUILDING  
INSTRUCTIONS

# Introduction



Thank you for purchasing the Tekno RC SCT410 2.0 1/10th 4WD competition electric SC kit. We are always working on new projects, so please check our website regularly at [www.teknorc.com](http://www.teknorc.com) or visit us on Facebook at [www.facebook.com/teknorc](http://www.facebook.com/teknorc) for all the latest news, parts, and kits.

Take your time! When you work your way through these building instructions, keep an eye out for the following important indicators below:

- **RED TEXT** - *This indicates important areas of the build process that should be observed.*



## Thread Lock icons

*Thread lock is always used when a screw is inserted into any metal part. (Included with kit)*



## Grease icons

*Grease is usually used on areas with movement and for sealing. (Included with kit)*

- **YOUTUBE** - *We also have many useful build videos on Youtube, so be sure to check these out!*  
<https://www.youtube.com/c/teknorc>

## Additional equipment and parts needed:

- 2+ channel radio transmitter and receiver
- Body
- Paint for body
- 1/10th scale ESC and motor system
- High torque steering servo (at least 250 oz/in)
- 2s (2 cell, 7.4v) LiPo battery (at least 5000mAh)
- 1/10th scale SCT tires, wheels & CA glue (or premounts)
- MOD1 Pinion 16 tooth - 20 tooth (TKR4176 - TKR4180)

## Tools needed:

- Hex drivers 1.5mm, 2.0mm, 2.5mm
- Nut drivers 5.0mm (TKR1107), 5.5mm (TKR1108), 7.0mm (TKR1109), 8.0mm (TKR1110)
- Hobby knife
- Needle-nose pliers
- Shock tool (TKR1115) OR adjustable (Crescent) wrench (for shock assembly)
- 4mm turnbuckle wrench (TKR1103) - 5.5/7.0 two sided wrench (TKR1119)

**Disclaimer:** Tekno RC is not responsible or liable for any property or personal damage, loss, or injury incurred as a result of using this product. This kit is meant for use by persons 14 years of age or older and in the strict confines of a legally permitted RC track or facility.

**Warnings:** Always double-check that your radio gear is working properly before operating vehicle. Never operate the vehicle indoors (unless the RC track is an indoor facility). Use caution while operating vehicle so as not to collide with people who may be turn marshalling or who might otherwise not be aware that a fast moving RC vehicle is in the vicinity.

**Warranty:** We warrant that the parts included in this kit are free from defects. If you find a defective part in your kit, please contact us at [info@teknorc.com](mailto:info@teknorc.com) and we will help to resolve the issue. If you modify any part prior to contacting us, the warranty claim will be void. We do not warranty parts that may be broken during operation of the vehicle or otherwise. Refer to the end of this instruction manual for a listing of spare/replacement and option parts. All spare parts and other info are available on our website ([www.teknorc.com](http://www.teknorc.com)) and through our network of domestic and international dealers and distributors.

# Bag A

## Center Differential

### (overview)

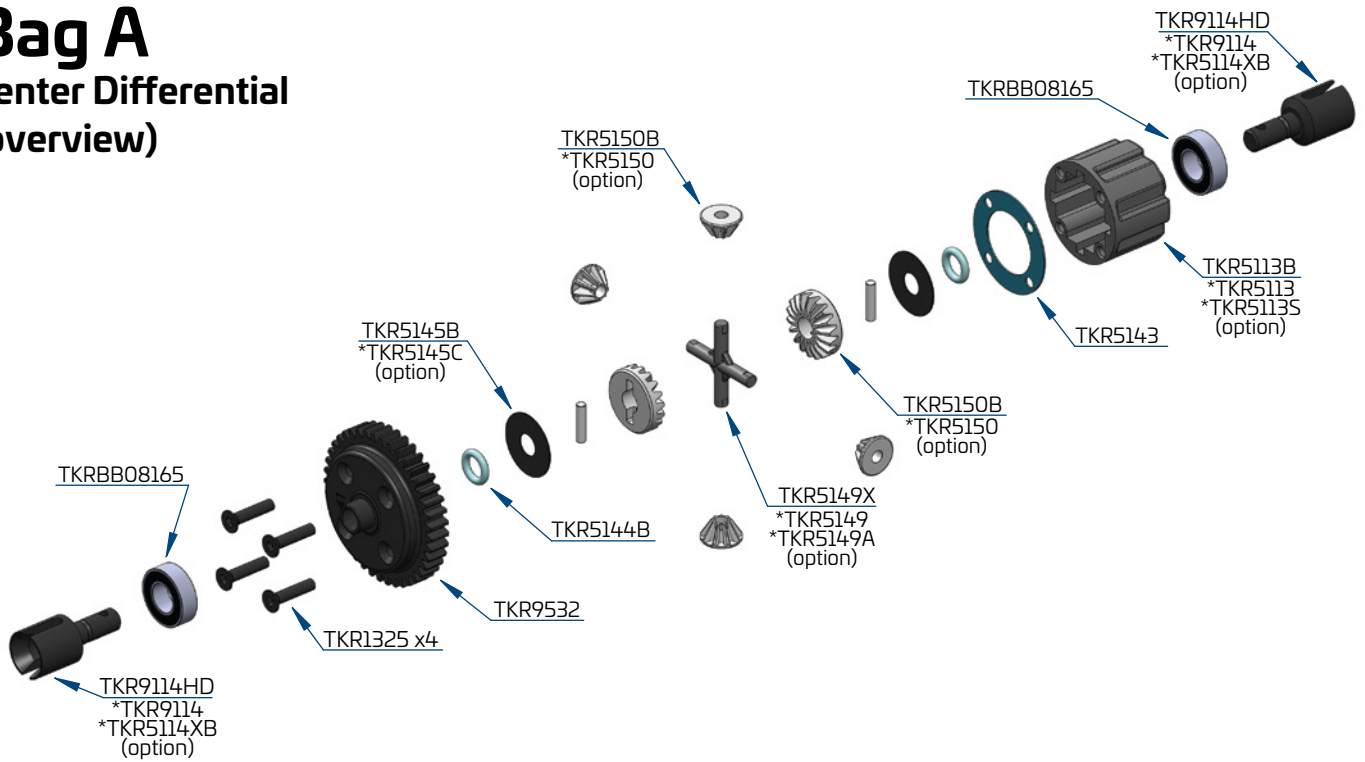

#### Step A-1

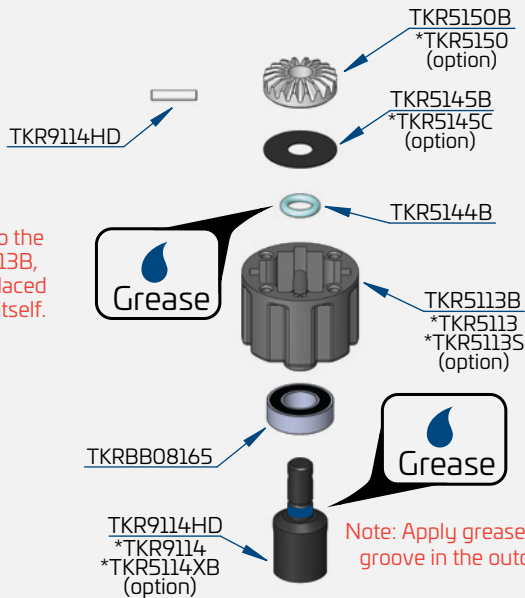

#### Step A-2

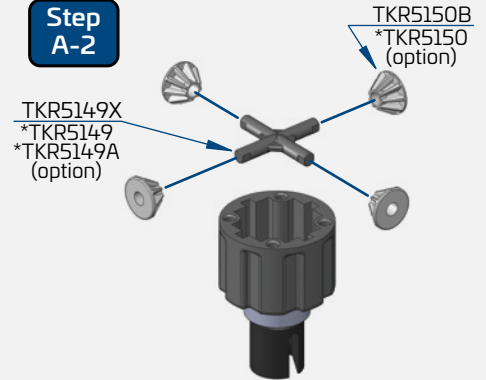

#### Step A-4

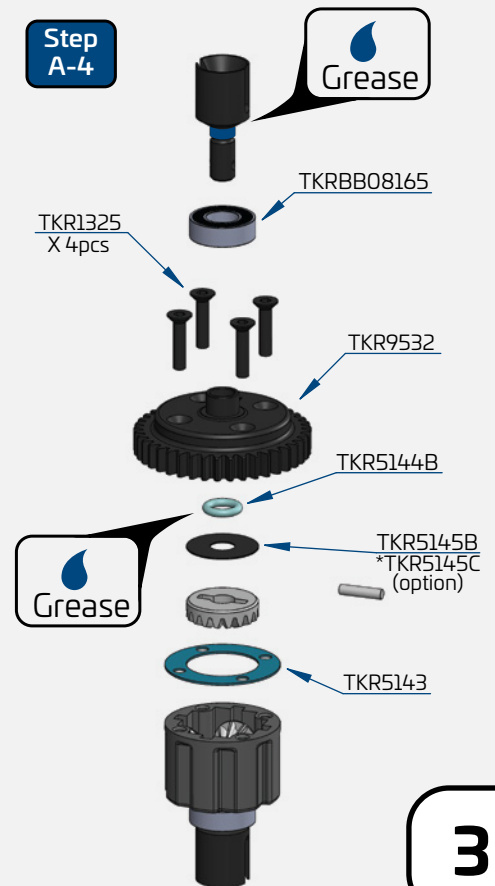

x4  
TKR1325  
M3x14mm Flat Head Screw

x2  
TKR5144B  
Differential O-rings

x2  
TKR5145B  
Differential Shims (6x17mm)

x2  
TKRBB08165  
Ball Bearing (8x16x5)

#### Step A-3



Fill with #15,000 CST oil to 1mm below full  
DO NOT OVER FILL



# Bag C Front Gearbox (overview)

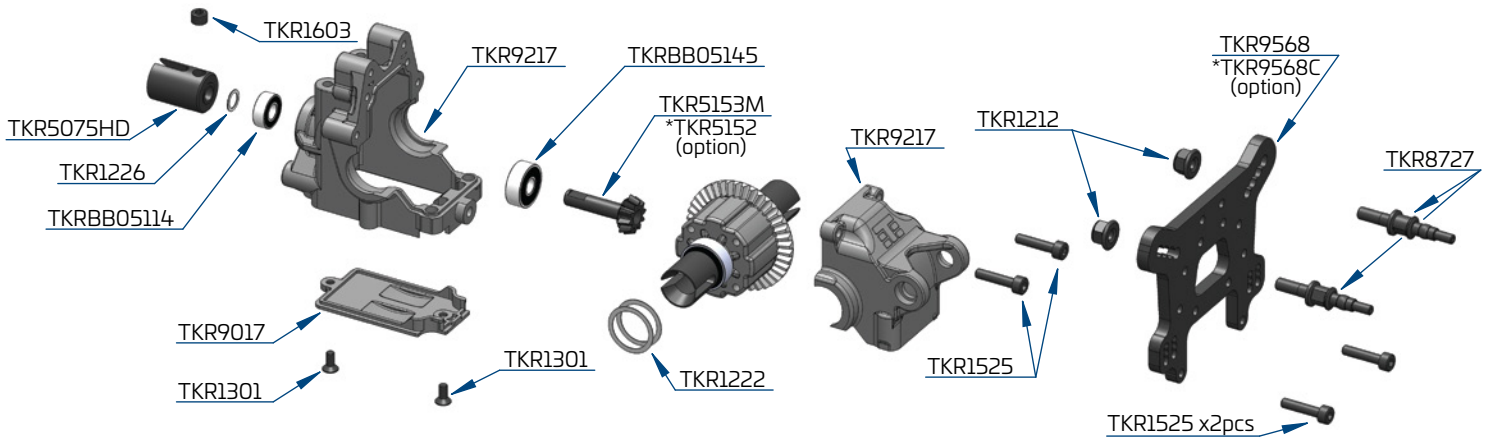



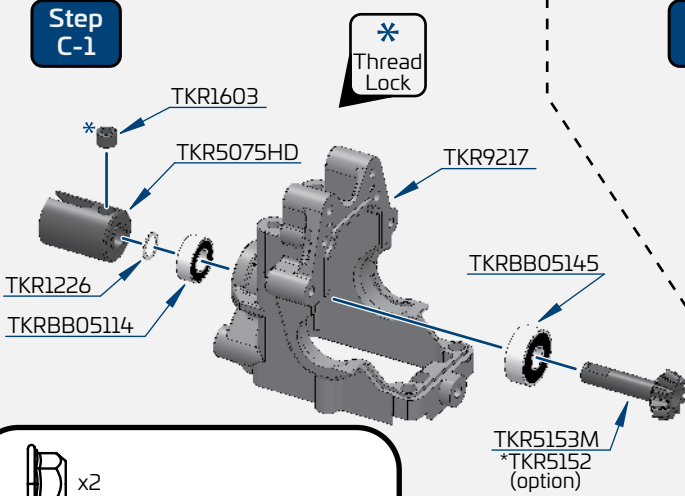

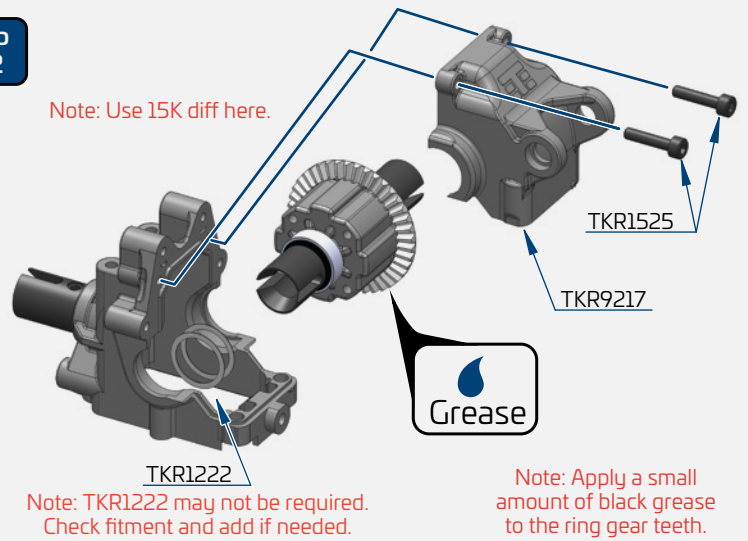

## Step C-1

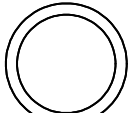

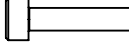
## Step C-2



-  x2  
TKR1212  
M4 Lock Nut Flange
-  x2  
TKR1222  
13x16x.1mm Shim
-  x1  
TKR1226  
M5x7x.2mm Shim
-  x2  
TKR1301  
M2.5x6mm Flat Head Screw
-  x4  
TKR1525  
M3x14mm Cap Head Screw
-  x1  
TKR1603  
M5x4mm Set Screw
-  x1  
TKRBB05114  
Ball Bearing (5x11x4)
-  x1  
TKRBB05145  
Ball Bearing (5x14x5)

## Step C-3

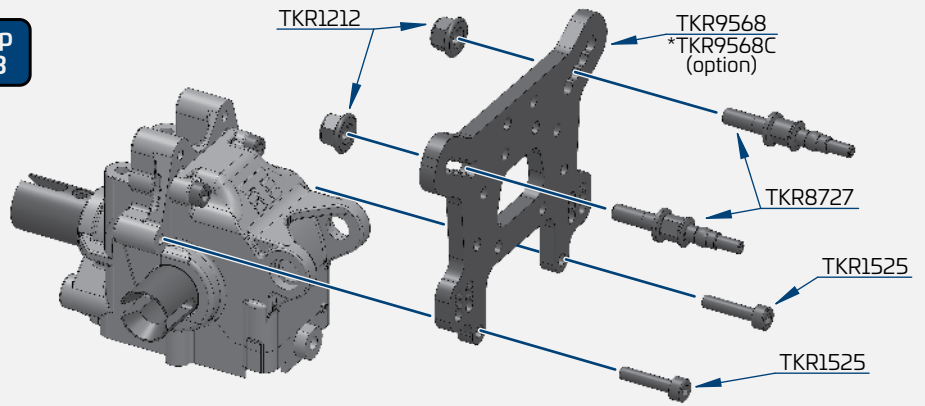

## Step C-4

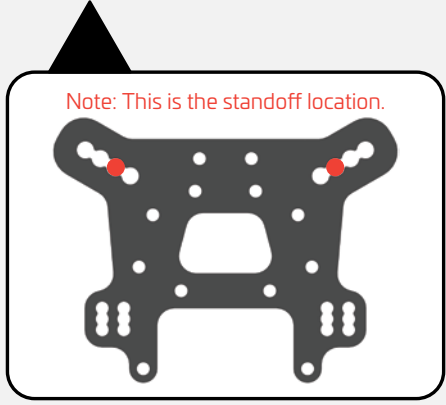
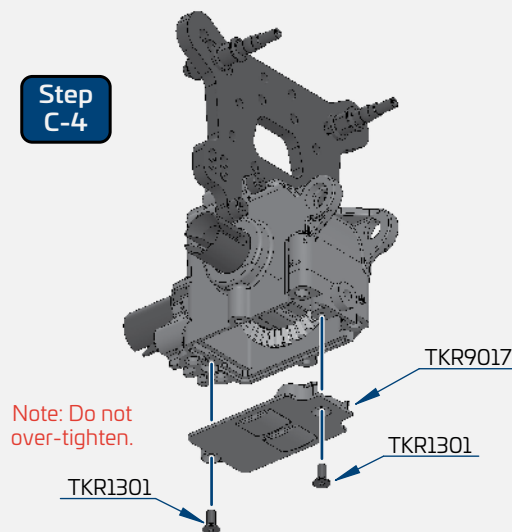

# Bag D Rear Gearbox (overview)

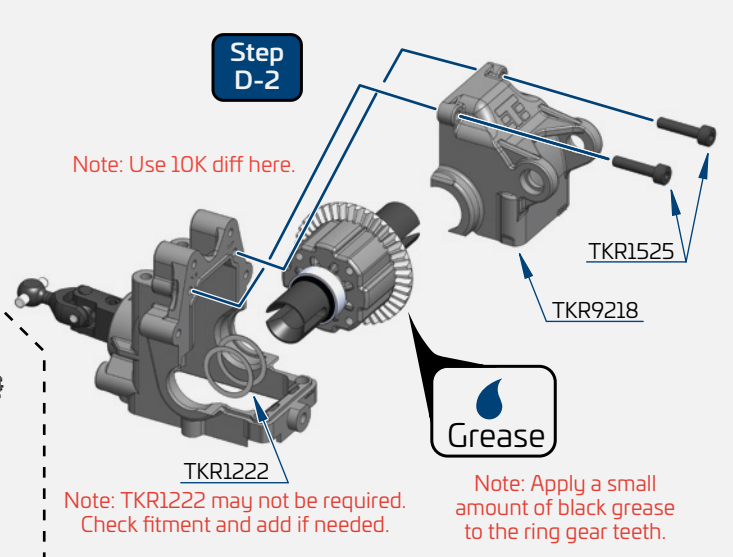
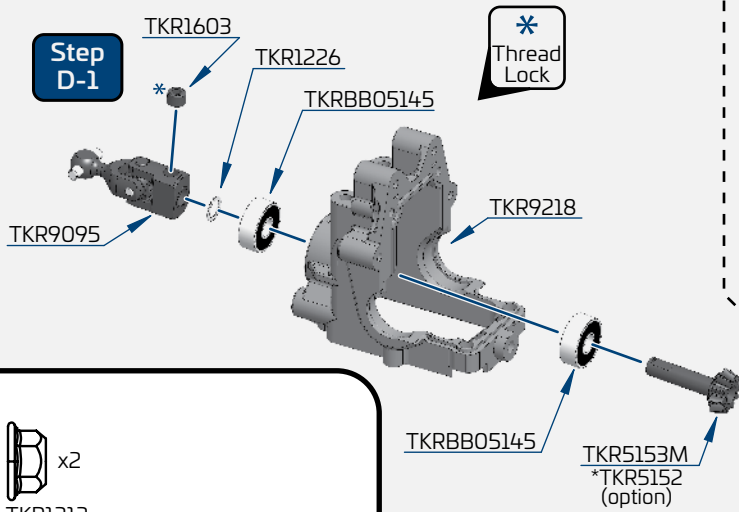
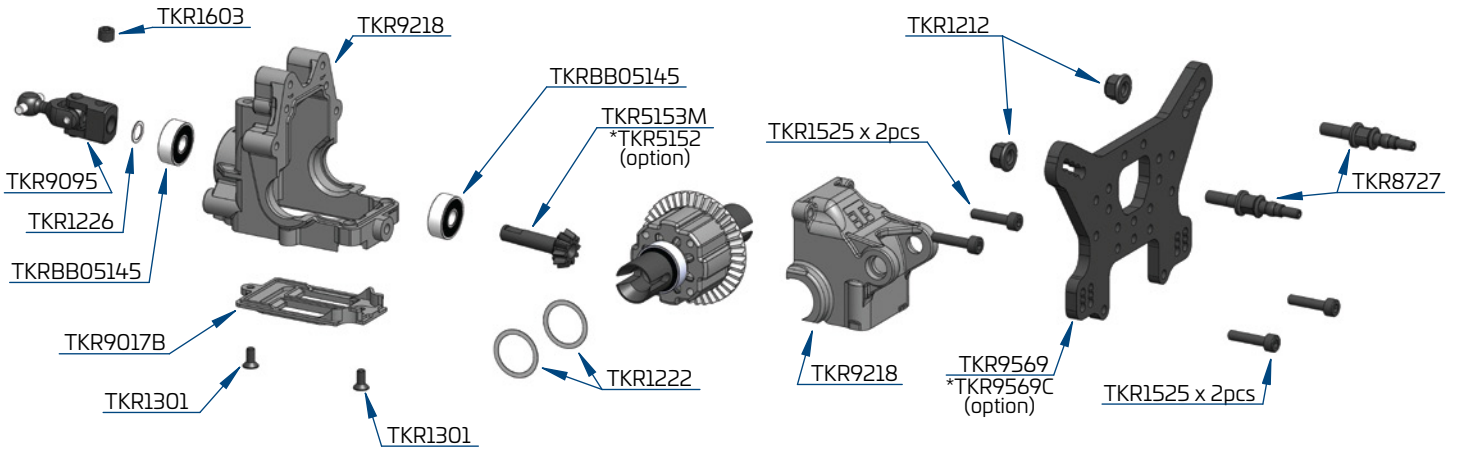

x2  
TKR1212  
M4 Lock Nut Flange

x2  
TKR1222  
13x16x.1mm Shim

x1  
TKR1226  
M5x7x.2mm Shim

x2  
TKR1301  
M2.5x6mm Flat Head Screw

x4  
TKR1525  
M3x14mm Cap Head Screw

x1  
TKR1603  
M5x4mm Set Screw

x2  
TKRBB05145  
Ball Bearing (5x14x5)

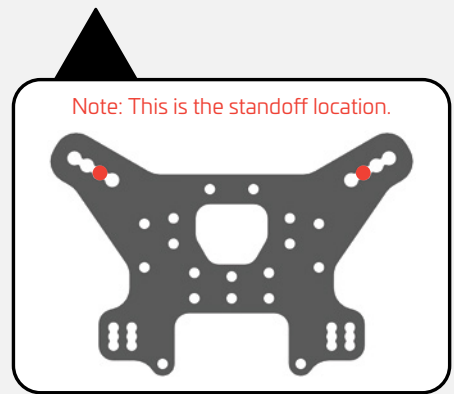
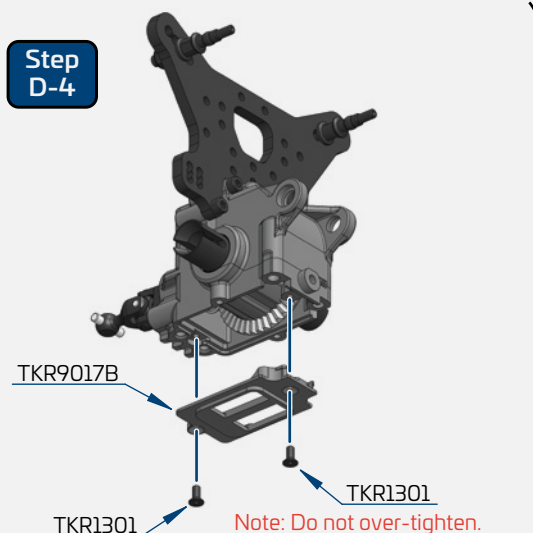
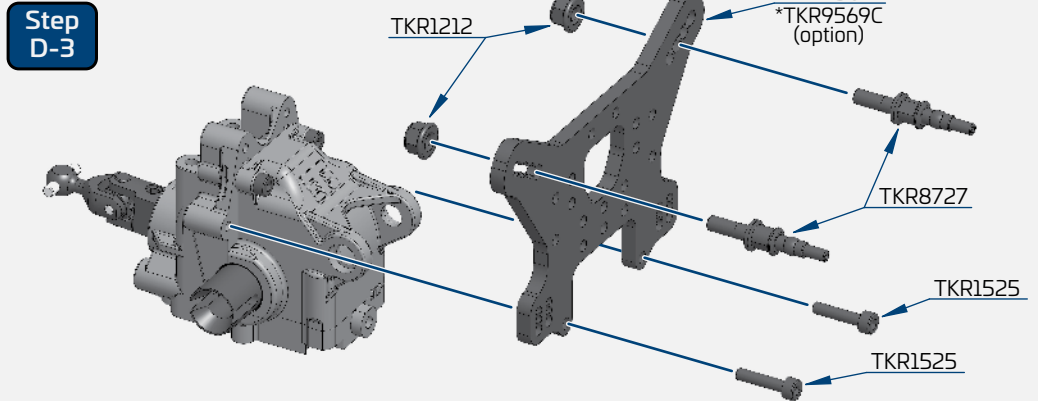

# Bag E Rear End Assembly

Optional Sway Bars  
(sold separately)  
\*TKR9593 - 2.2mm  
\*TKR9593 - 2.3mm  
\*TKR9593 - 2.4mm  
\*TKR9593 - 2.5mm  
\*TKR9594 - 2.6mm  
\*TKR9594 - 2.7mm  
\*TKR9594 - 2.8mm  
\*TKR9594 - 2.9mm  
\*TKR9594 - 3.0mm

**Step  
E-1**

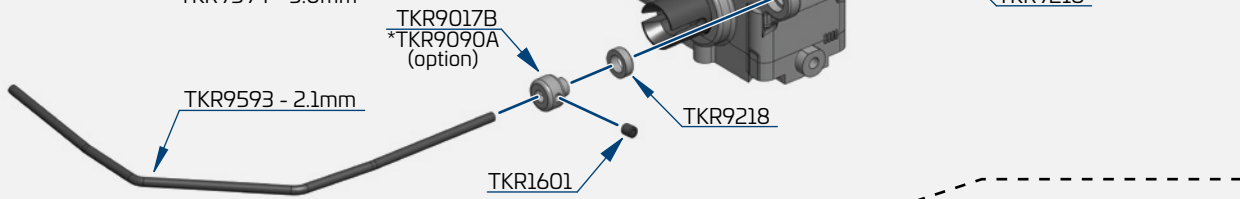

**Step  
E-2**

\*  
Thread  
Lock

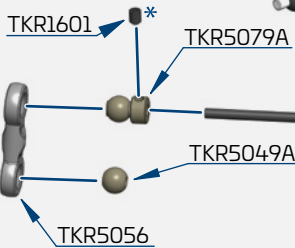

Note: Repeat this step for the other side.

**Step  
E-3**

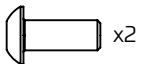
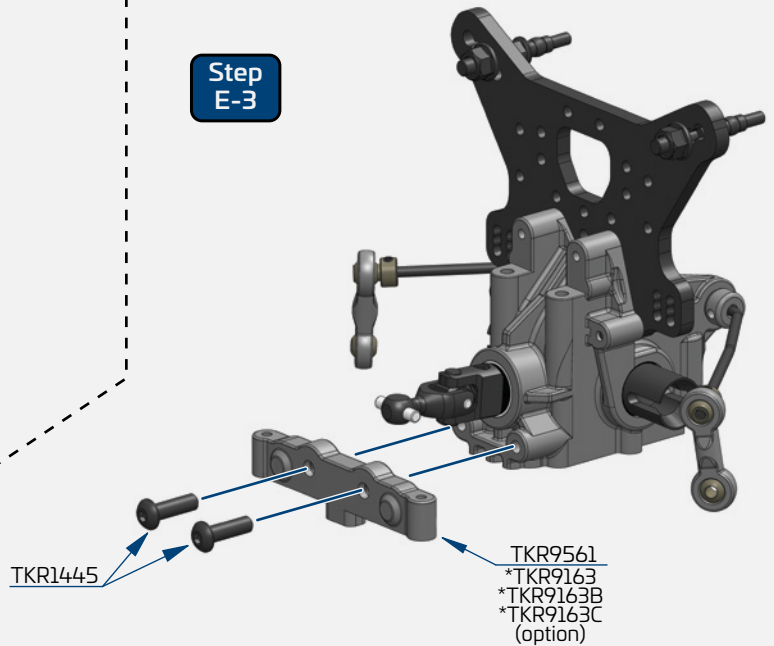

TKR1238  
M4x10mm Droop Screw

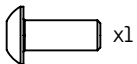

TKR1443  
M4x10mm Button Head Screw

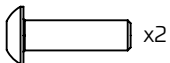

TKR1445  
M4x14mm Button Head Screw

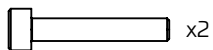

TKR1528  
M3x18mm Cap Head Screw



TKR1601  
M3x4mm Set Screw

**Step  
E-4**

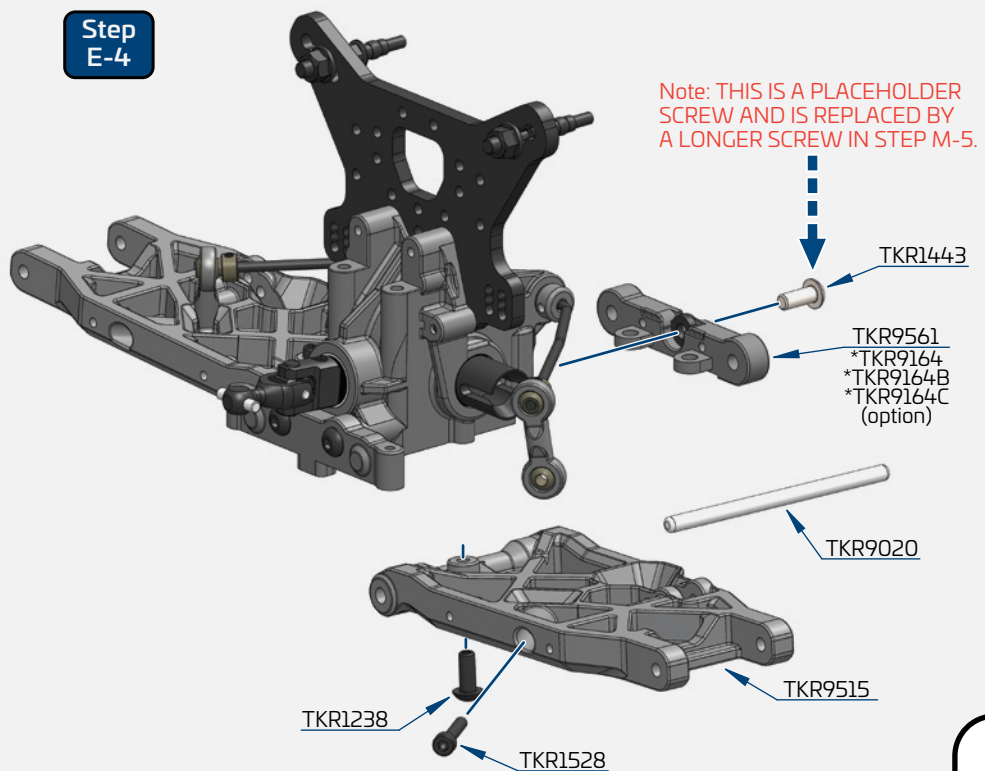

Note: THIS IS A PLACEHOLDER  
SCREW AND IS REPLACED BY  
A LONGER SCREW IN STEP M-5.

Note: Repeat this step for the other side.

# Bag F

## Rear Hub

Step  
F-1

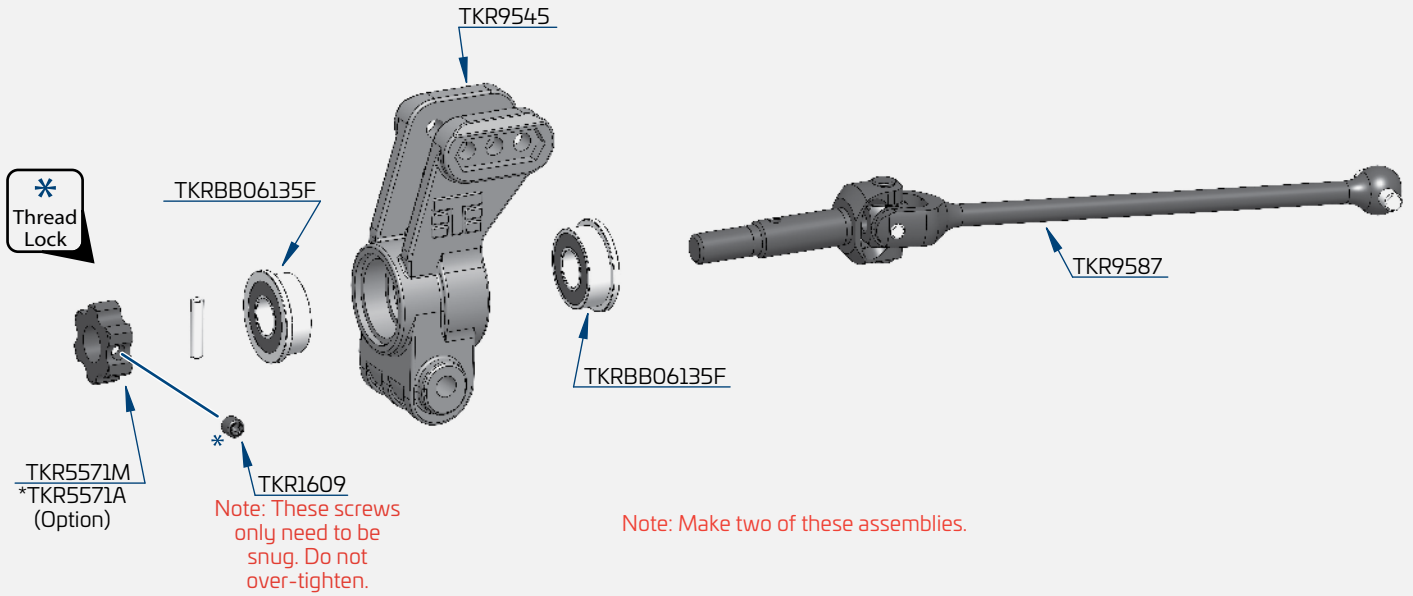

Step  
F-2

### Wheelbase Shims

(Shims)  
 (Thick - 2mm)
  (Thin - 1mm)

0mm  
FRONT

3mm  
REAR

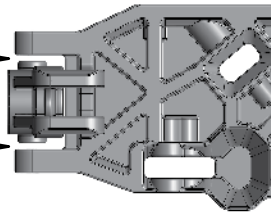

-  x4  
TKR1201  
M3 Locknut Black
-  x2  
TKR1609  
M3x3mm Set Screw
-  x4  
TKRBB06135F  
Flanged Ball Bearing (6x13x5)

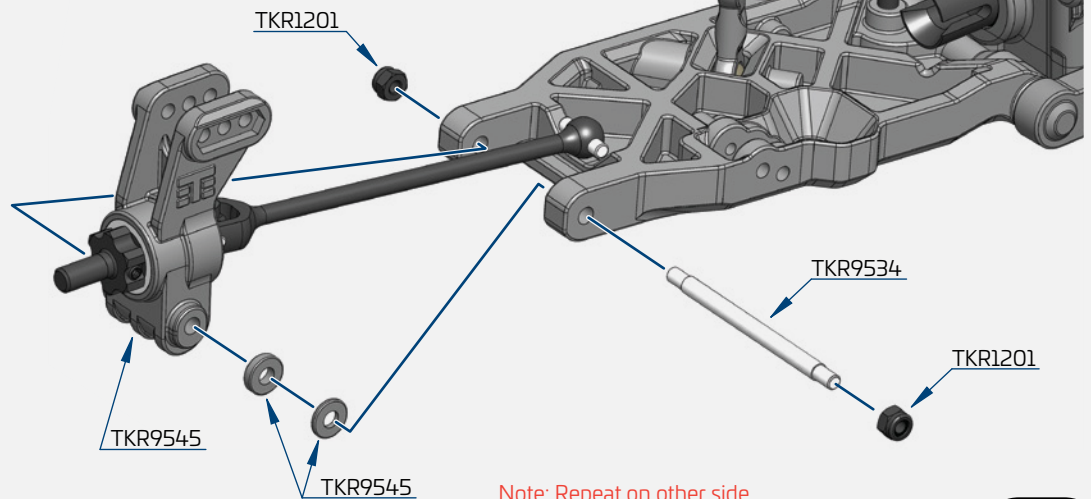

# Bag F

## Rear Camber Links

Step F-3

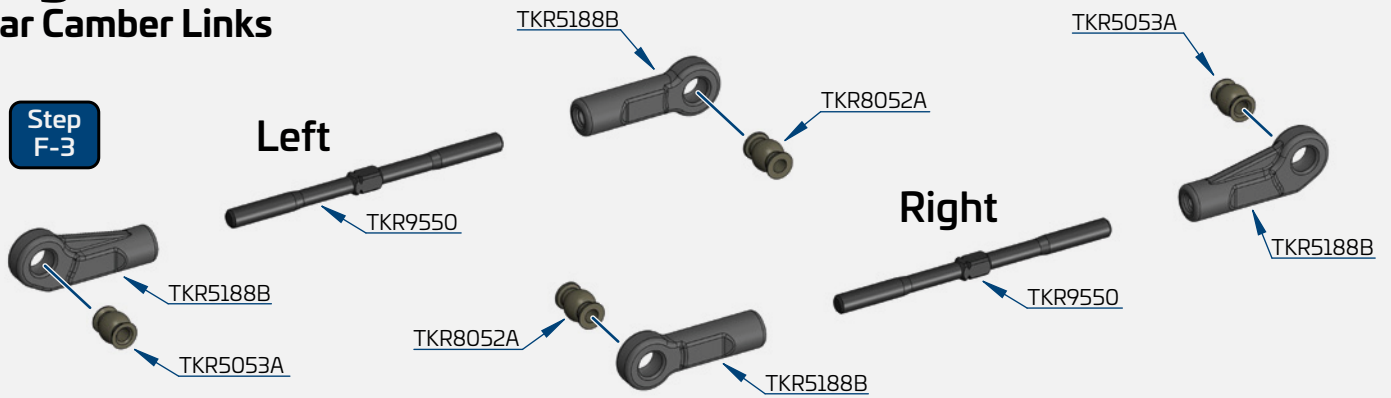

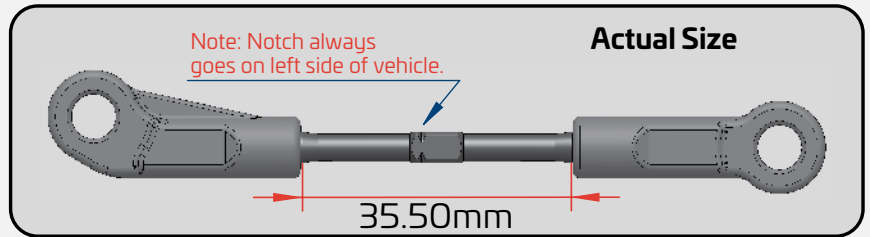

**Build Tip:** Use some grease or Chapstick on the threads to help prevent "pop-off" when adjustments are being made.

**Build Note:** Hold the turnbuckle stationary with pliers and push the rod end hard onto the turnbuckle while turning at the same time. Keep in mind that one end of the turnbuckle has normal threads and the other has reverse threads. Start the rod end straight and it will thread on straight.



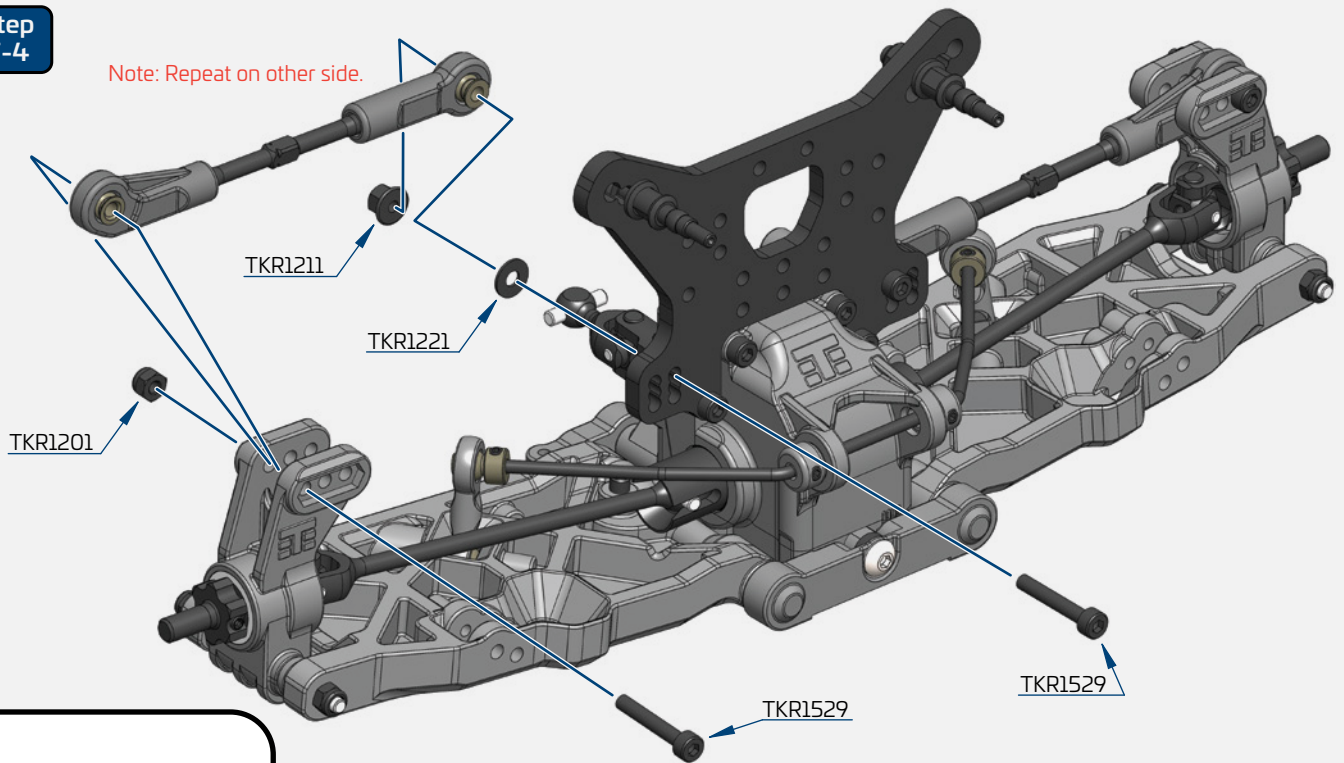

Step F-4



 x4  
TKR1201  
M3 Locknut Black

 x2  
TKR1221  
M3 Lock Nut Flange Black

 x2  
TKR1221  
M3x8mm Washer

 x4  
TKR1529  
M3x20mm Cap Head Screw

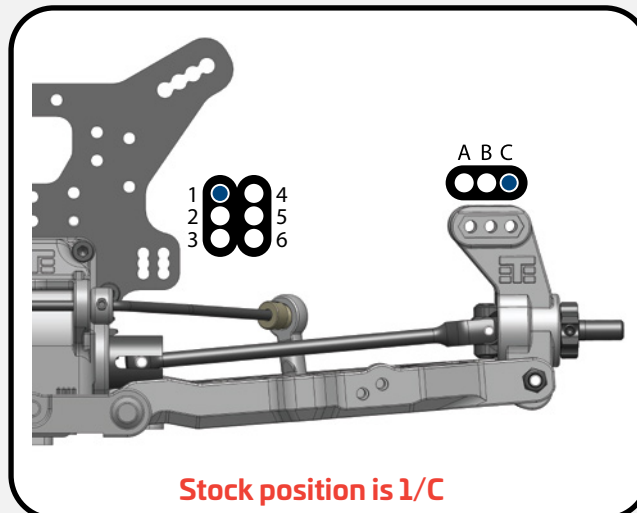

# Bag G Front End Assembly

Optional Sway Bars  
(sold separately)  
\*TKR9577 - 2.2mm  
\*TKR9577 - 2.3mm  
\*TKR9577 - 2.4mm  
\*TKR9577 - 2.5mm  
\*TKR9578 - 2.6mm  
\*TKR9578 - 2.7mm  
\*TKR9578 - 2.8mm  
\*TKR9578 - 2.9mm  
\*TKR9578 - 3.0mm

## Step G-1

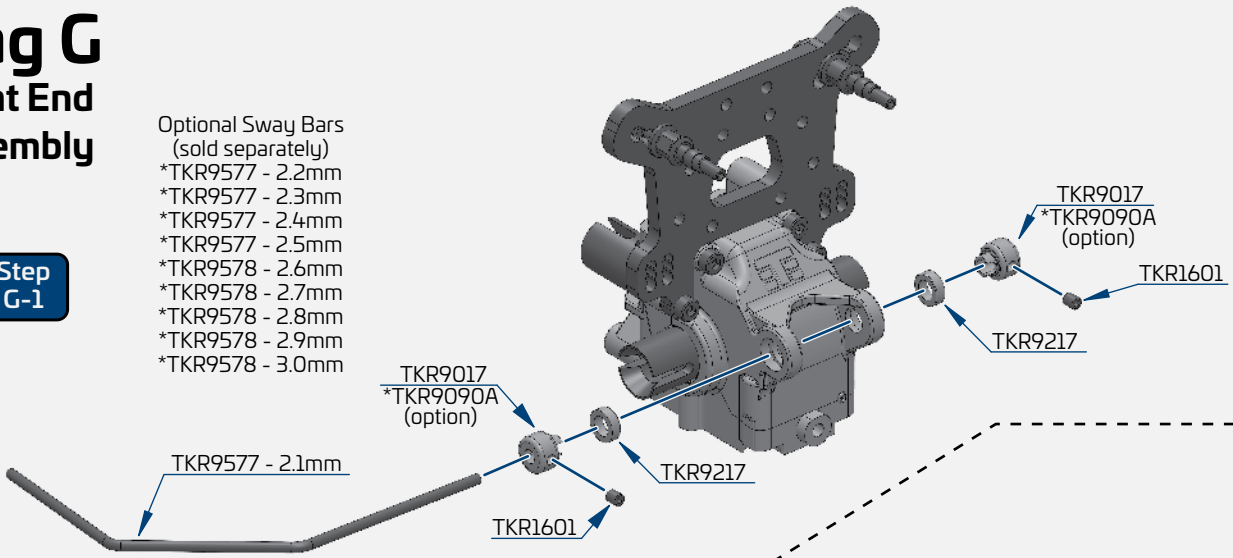

## Step G-2

\*  
Thread  
Lock

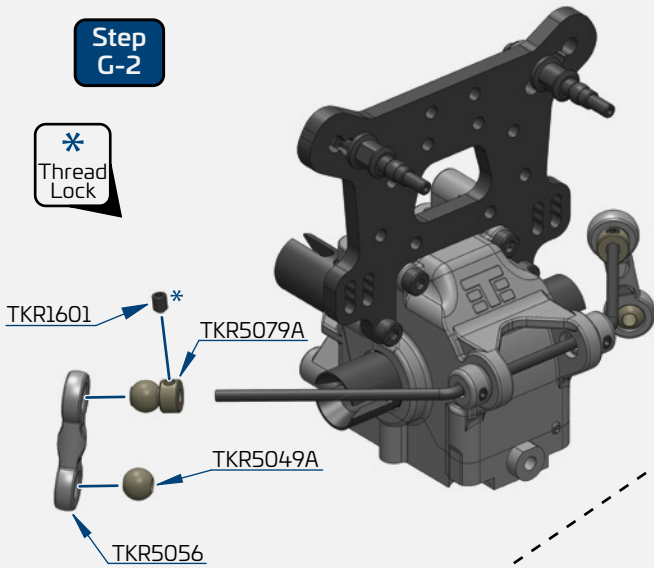

Note: Repeat this step for the other side.

## Step G-3

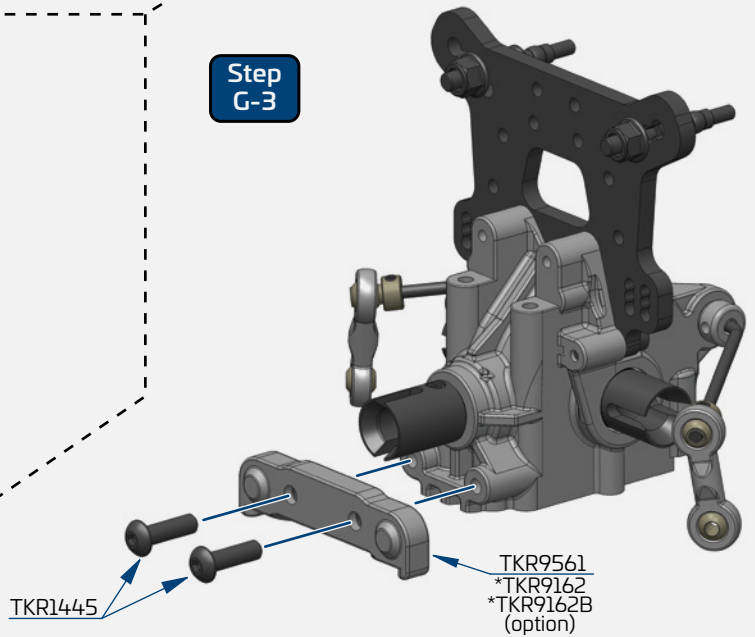

## Step G-4



TKR1238  
M4x10mm Droop Screw

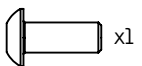

TKR1443  
M4x10mm Button Head Screw

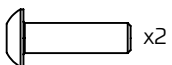

TKR1445  
M4x14mm Button Head Screw

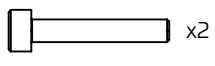

TKR1528  
M3x18mm Cap Head Screw

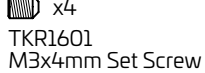

TKR1601  
M3x4mm Set Screw

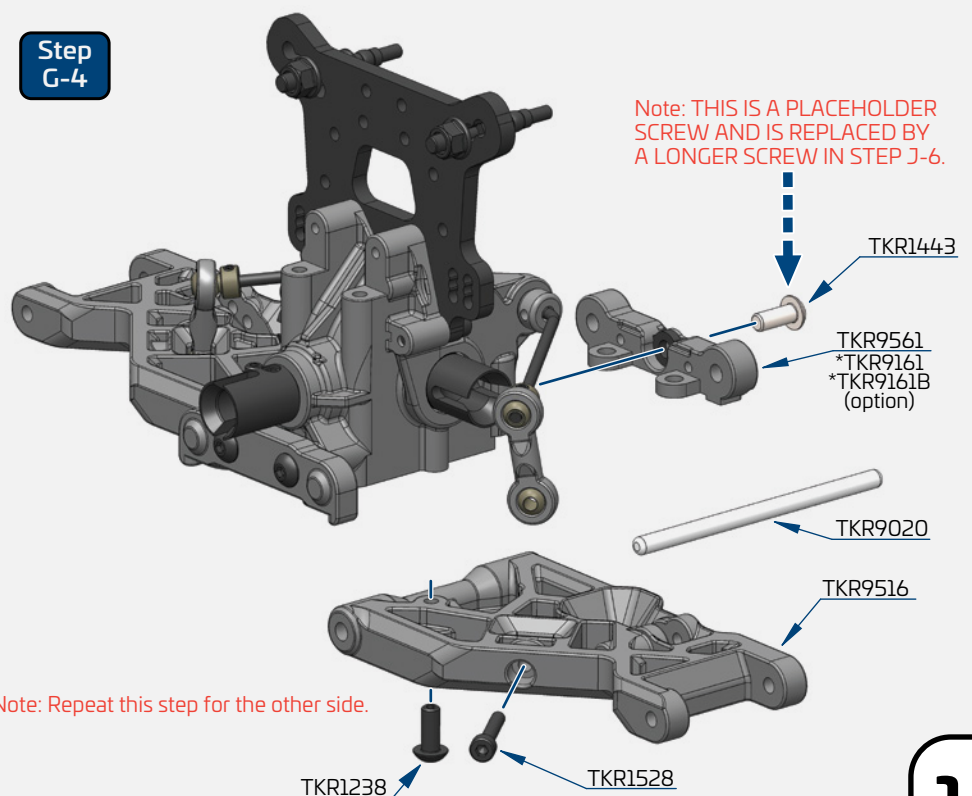

Note: Repeat this step for the other side.

Note: THIS IS A PLACEHOLDER  
SCREW AND IS REPLACED BY  
A LONGER SCREW IN STEP J-6.

# Bag H

## Front Spindle & Carrier Assembly

Step H-1

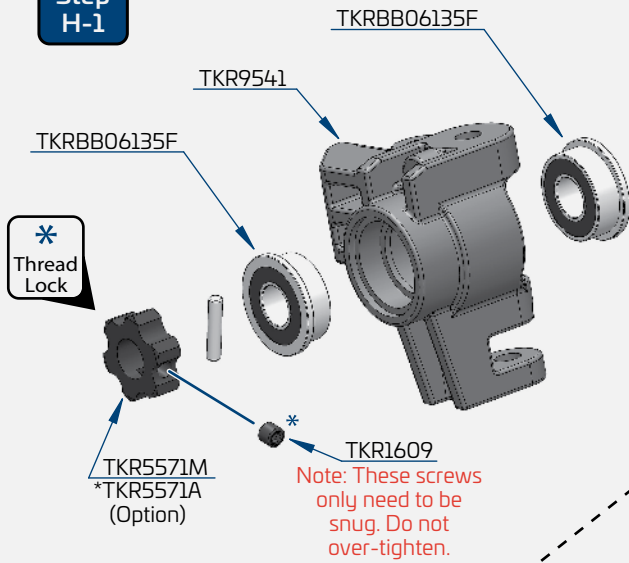

Note: Make two of these assemblies.

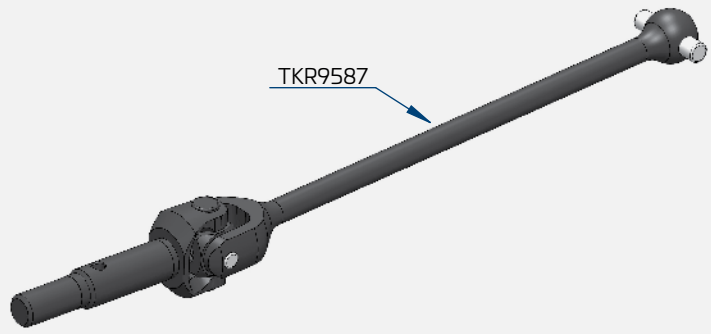

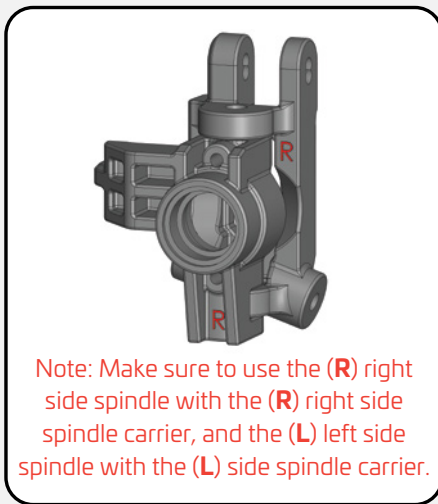

Step H-2

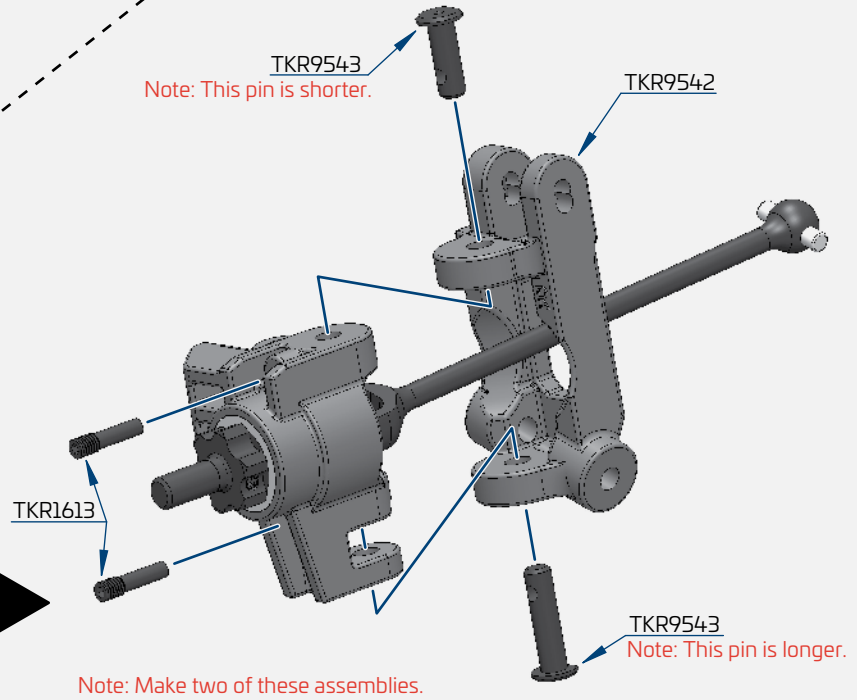

Note: This pin is shorter.

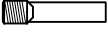
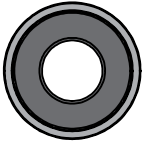

-  x4  
TKR1201  
M3 Locknut Black
-  x2  
TKR1609  
M3x3mm Set Screw
-  x4  
TKR1613  
M3x12mm Screw Pin
-  x4  
TKRBB06135F  
Flanged Ball Bearing (6x13x5)

Step H-3

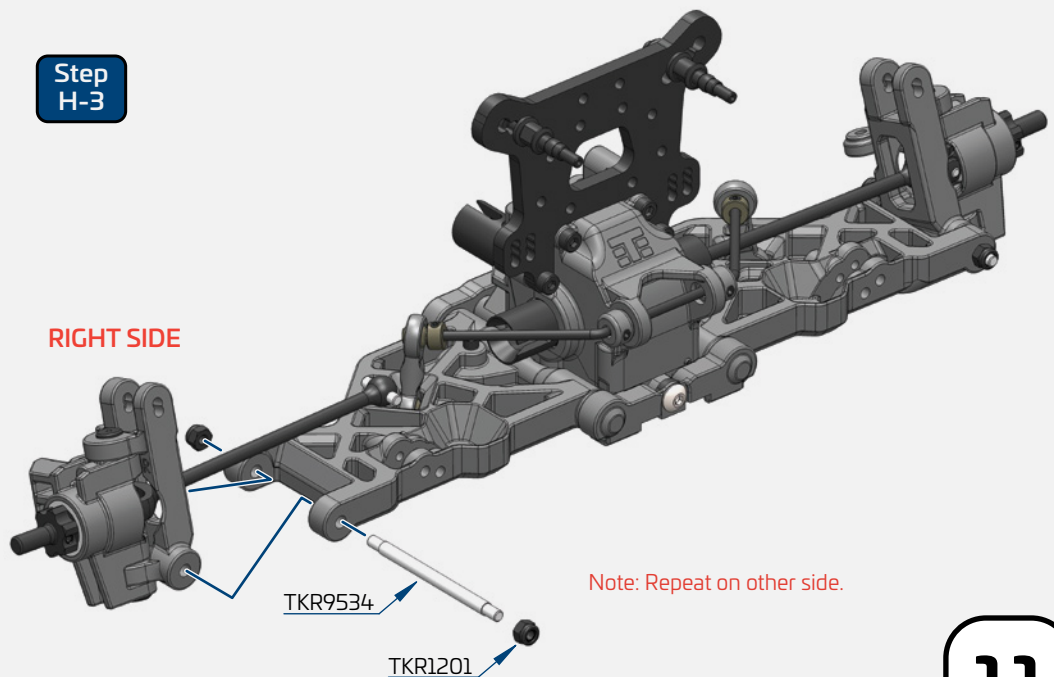

# Bag H

## Front Camber Links

Step H-4

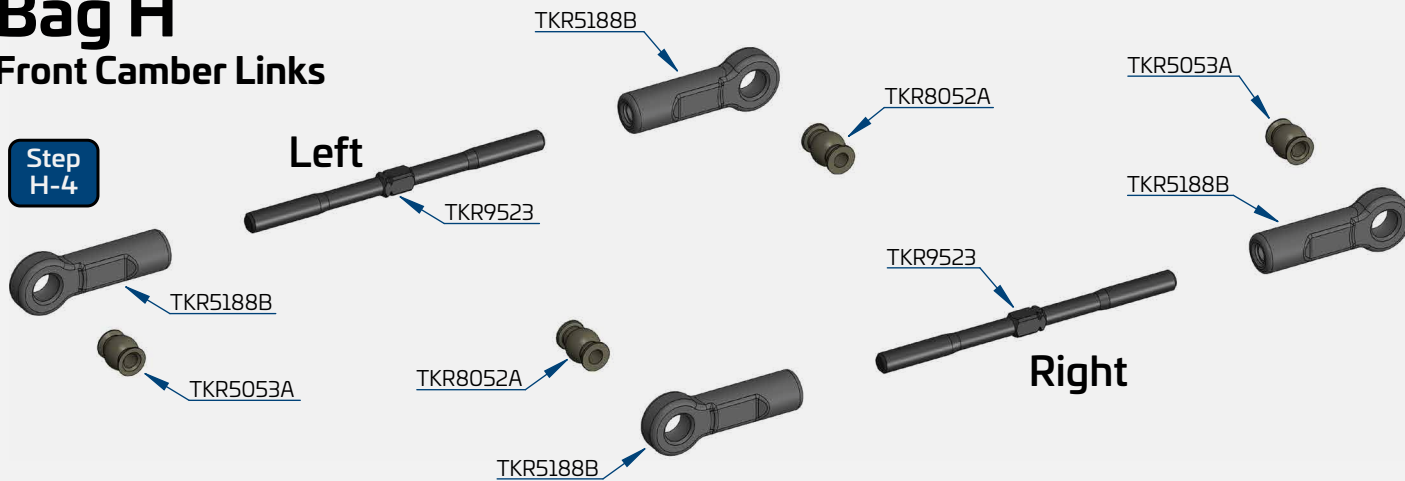

**Build Tip:** Use some grease or Chapstick on the threads to help prevent "pop-off" when adjustments are being made.

**Build Note:** Hold the turnbuckle stationary with pliers and push the rod end hard onto the turnbuckle while turning at the same time. Keep in mind that one end of the turnbuckle has normal threads and the other has reverse threads. Start the rod end straight and it will thread on straight.

## Front Camber Links

Note: Notch always goes on left side of vehicle.

Actual Size

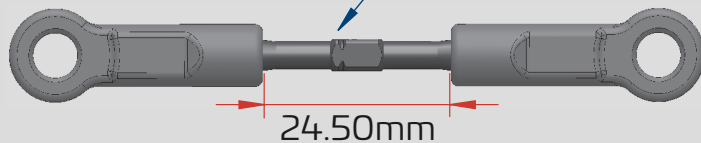

Step H-5

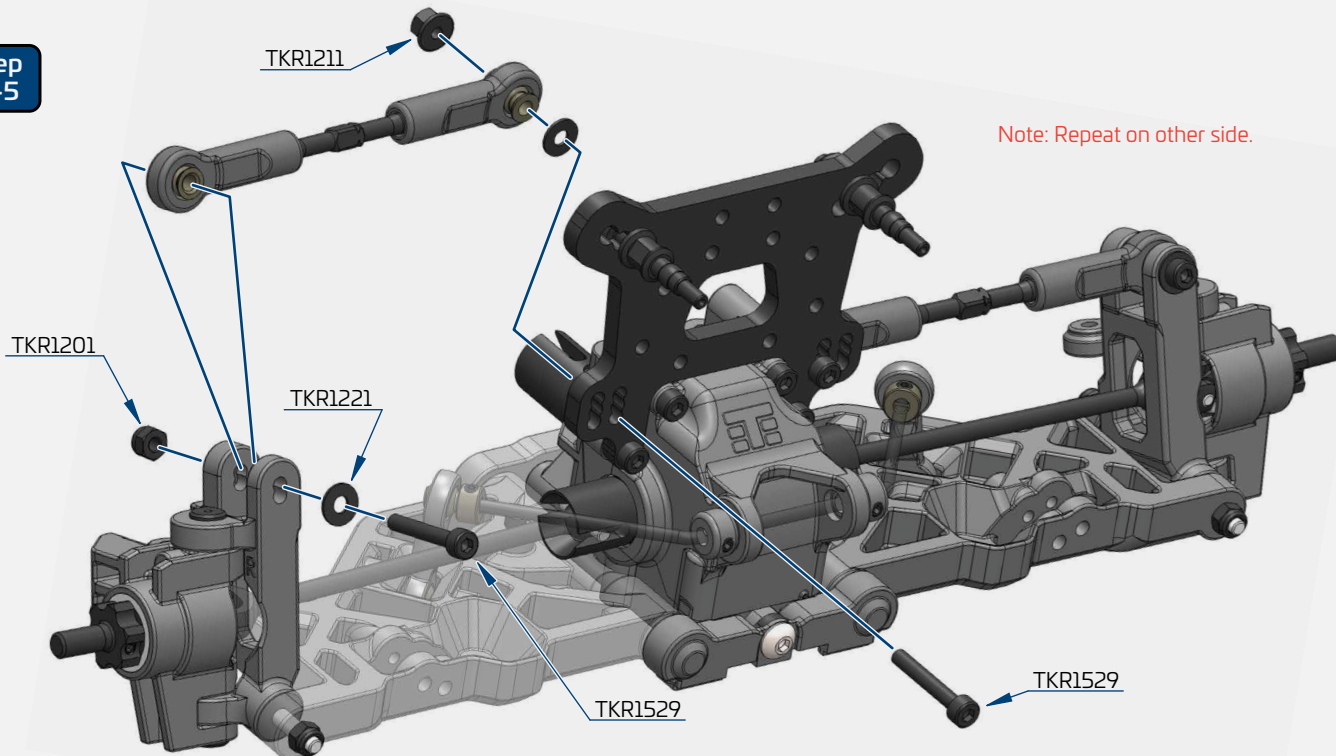

Note: Repeat on other side.

 x2  
TKR1211  
M3 Lock Nut Flange Black

 x2  
TKR1201  
M3 Locknut Black

 x4  
TKR1221  
M3x8mm Washer

 x4  
TKR1529  
M3x20mm Cap Head Screw

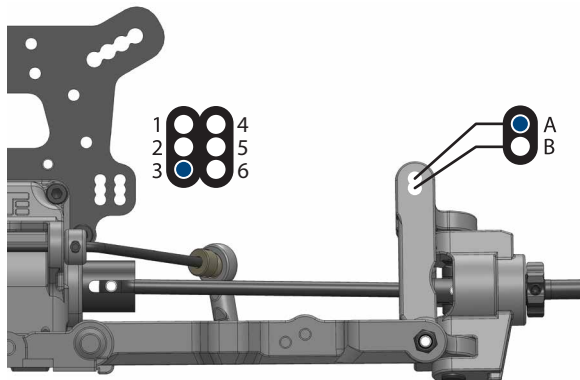

Stock position is 3/A



# Bag J

## Front End Assembly

### Step J-1

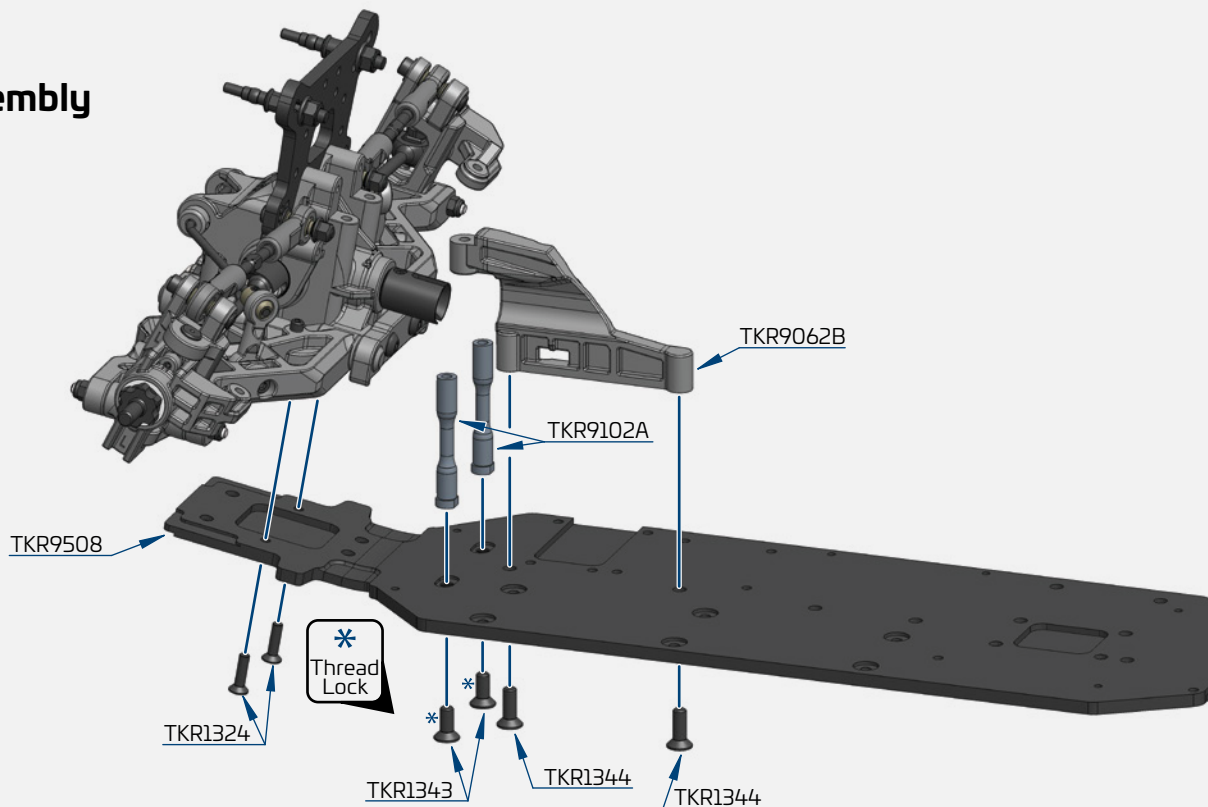

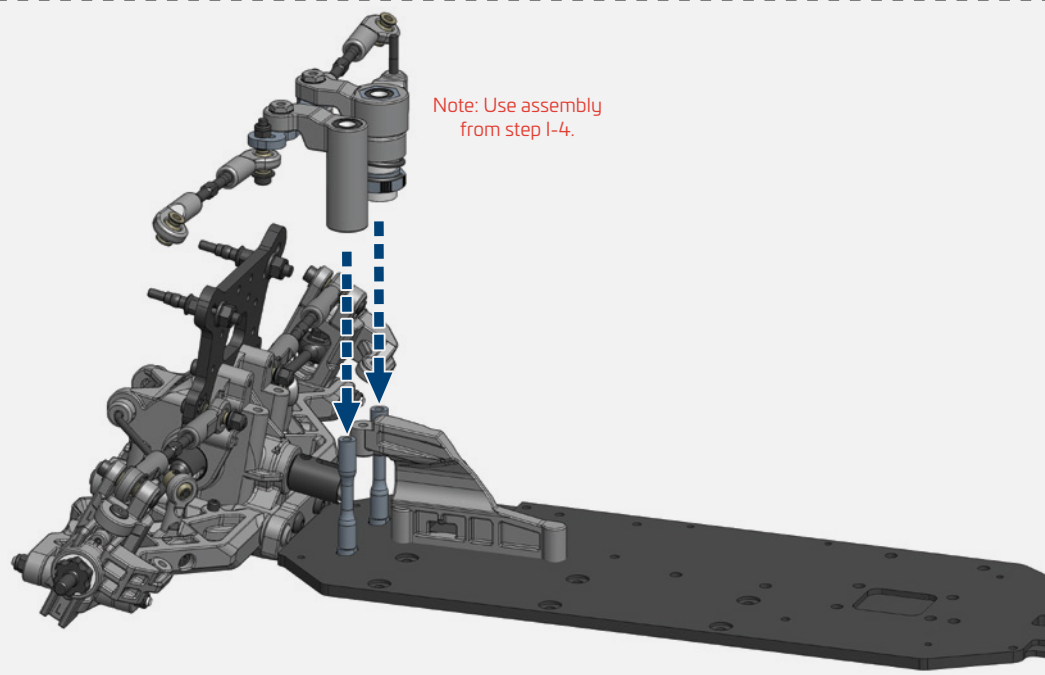

### Step J-2

Note: Use assembly from step I-4.





 x2  
TKR1324  
M3x12mm Flat Head Screw

 x2  
TKR1343  
M4x10mm Flat Head Screw

 x2  
TKR1344  
M4x12mm Flat Head Screw

 x2  
TKR1443  
M4x10mm Button Head Screw

 x2  
TKR1444  
M4x12mm Button Head Screw

 x1  
TKR1447  
M4x16mm Button Head Screw

 x2  
TKR1525  
M3x14mm Cap Head Screw

### Step J-3

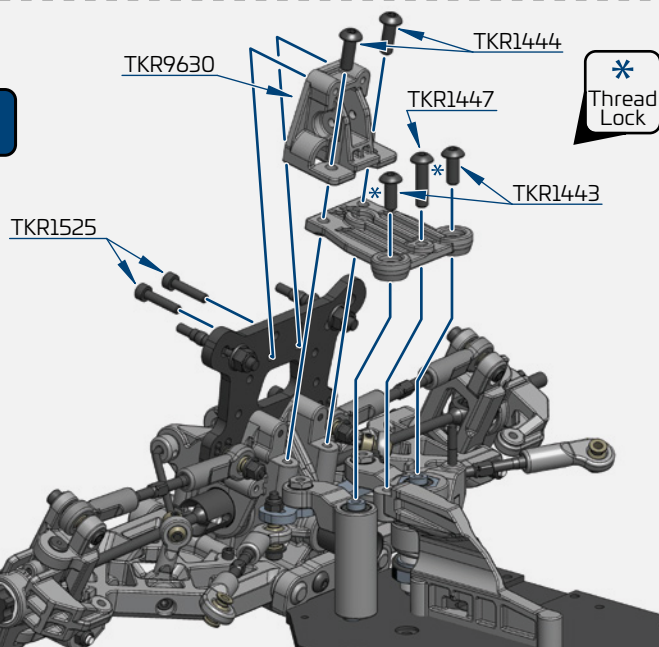

# Bag J

## Front/Rear Assembly

### Step J-4

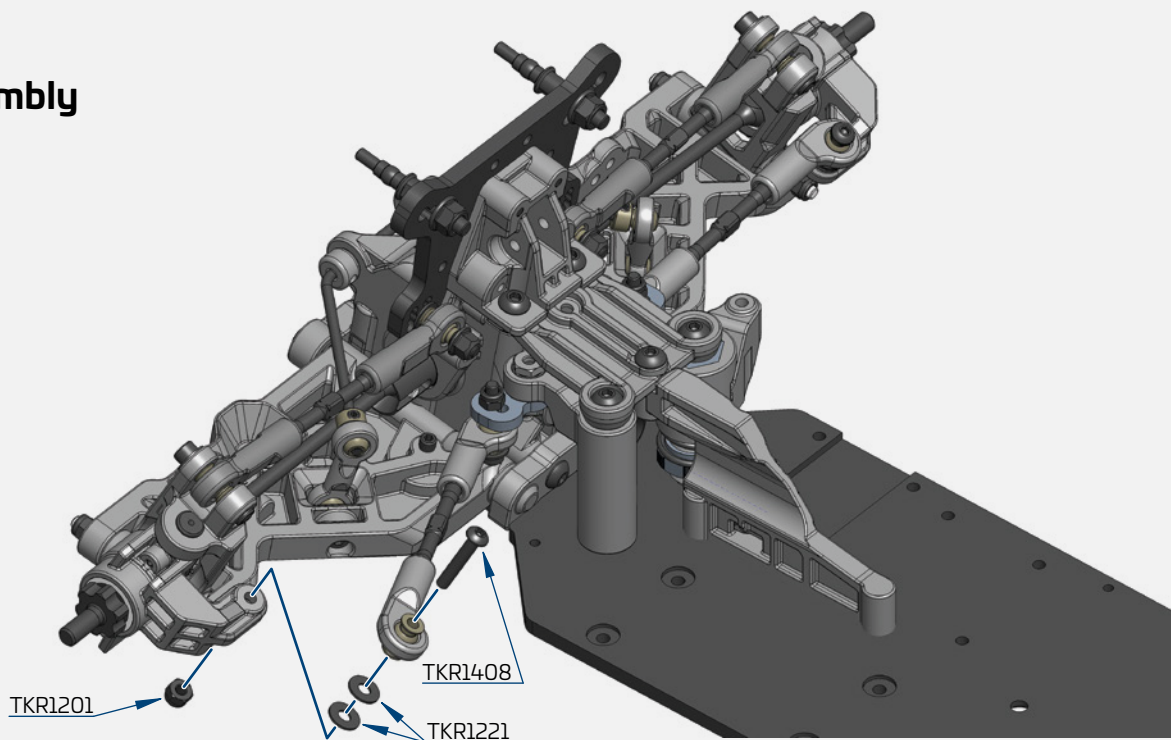

### Step J-5

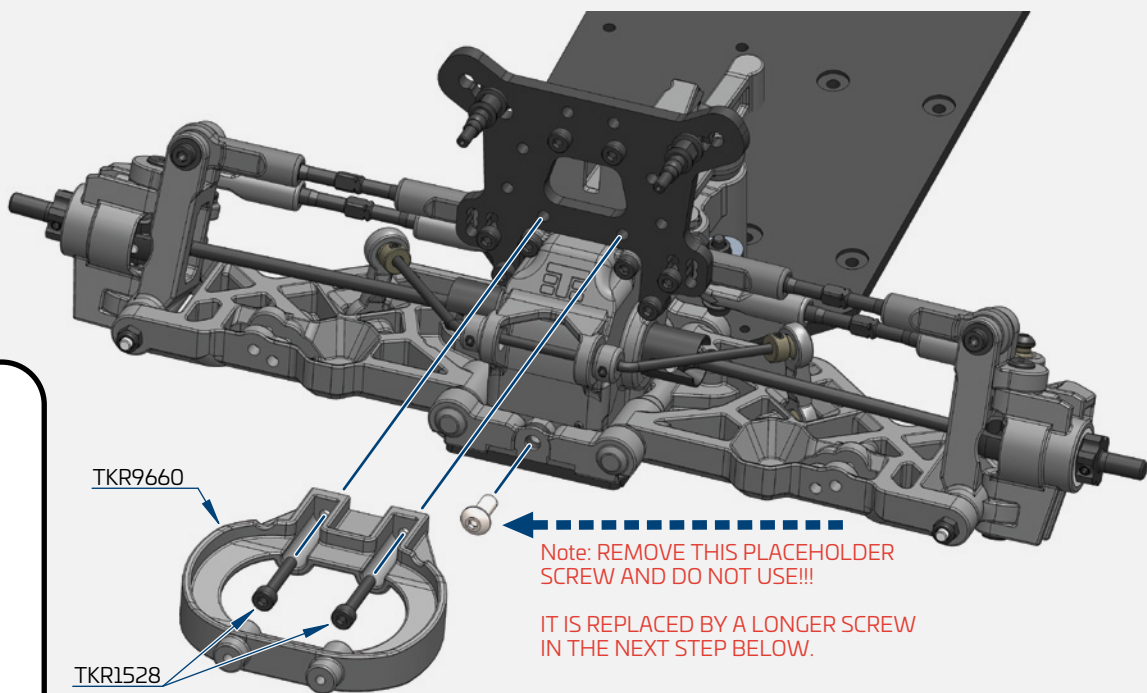

 x2  
TKR1201  
M3 Locknut Black

 x4  
TKR1221  
M3x8mm Washer

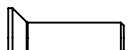
 x2  
TKR1346  
M4x15mm Flat Head Screw

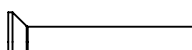
 x2  
TKR1350  
M4x25mm Flat Head Screw

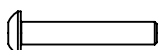
 x2  
TKR1408  
M3x18mm Button Head Screw

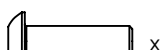
 x1  
TKR1445  
M4x14mm Button Head Screw

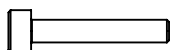
 x2  
TKR1528  
M3x18mm Cap Head Screw

### Step J-6

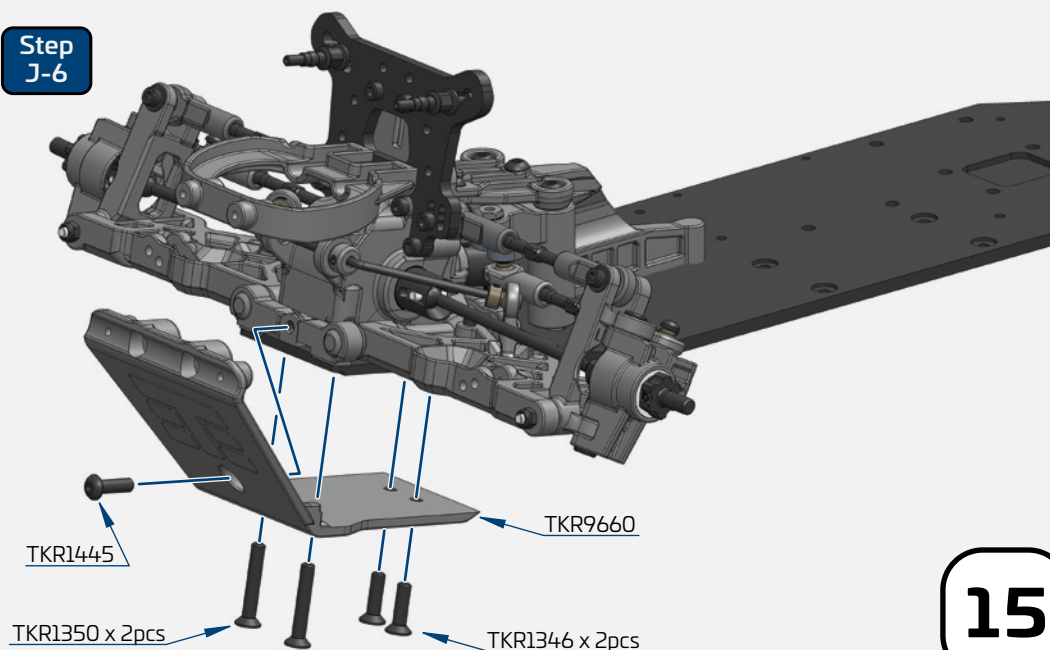

# Bag K Motor/Servo

Step  
K-1

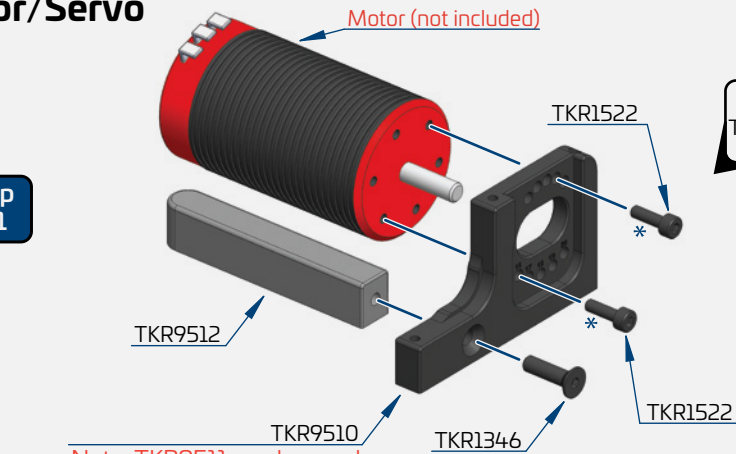

Note: TKR9511 can be used here if using any pinion below 16 tooth.  
\*Sold separately.

\*  
Thread  
Lock

## 1 Piece Motor Mount

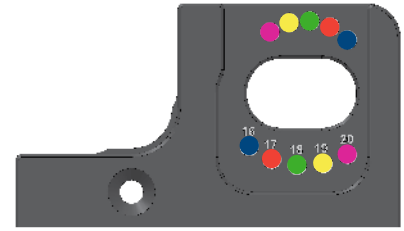

Note: Laser etched numbers indicates what MOD 1 pinion is to be used with each set of holes. Match the corresponding color for the second hole.

## MOD 1 Gearing Recommendations

Note: Gearing recommendations in **RED** require the use of TKR9511 motor mount. This mount is not included and sold separately.

Motor 550/3660 4-Pole	Battery	Small Track (pinion)	Large Track (pinion)
		(50-120 ft Straight)	(120-180 ft Straight)
4600kv	2 Cell	<b>14 tooth</b>	<b>15 tooth</b>
4300kv	2 Cell	<b>15 tooth</b>	16 tooth
4000kv	2 Cell	16 tooth	17 tooth
3800kv	2 Cell	17 tooth	18 tooth
3500kv	2 Cell	18 tooth	20 tooth
3200kv	2 Cell	20 tooth	(not recommended)
3200kv	3 Cell	<b>13 tooth</b>	<b>14 tooth</b>
3000kv	3 Cell	<b>14 tooth</b>	16 tooth
2800kv	3 Cell	16 tooth	17 tooth
2400kv	3 Cell	18 tooth	19 tooth

Note: These gearing recommendations are just starting points. Each user might have to adjust based on batteries used, individual preferences, and specific tracks.

Step  
K-2

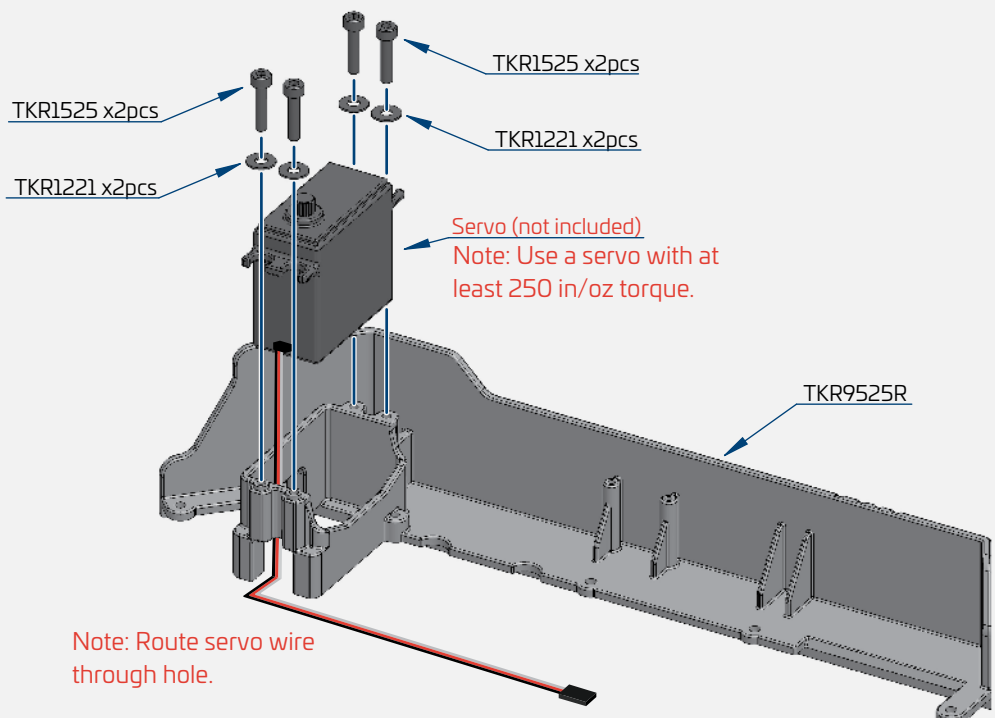

Note: Route servo wire through hole.

x4  
TKR1221  
M3x8mm Washer

x1  
TKR1346  
M4x15mm Flat Head Screw

x2  
TKR1522  
M3x8mm Cap Head Screw

x4  
TKR1525  
M3x14mm Cap Head Screw



# Bag L

## Battery Tray/ Servo Link

Step  
L-1

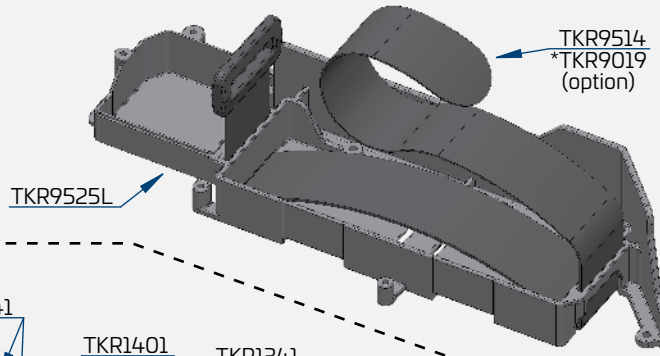

Note: Install battery strap as show in the image. Do this before moving to the next step.

Step  
L-2

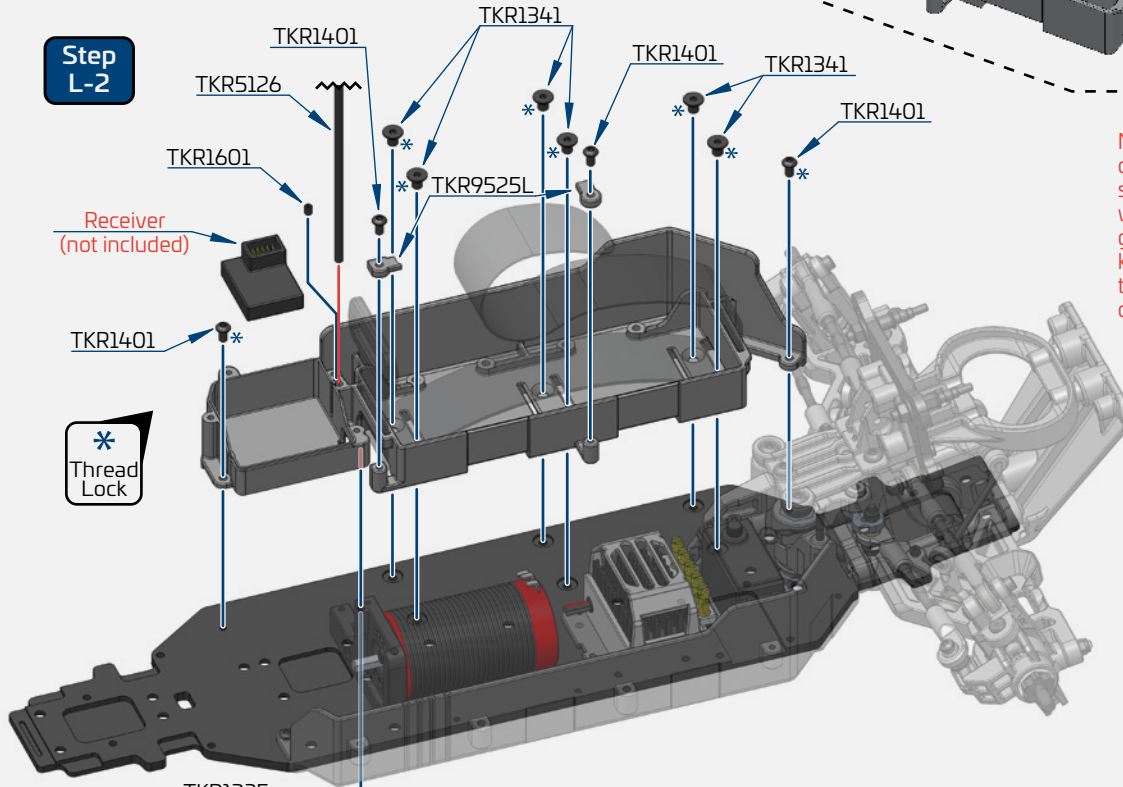

Note: Refer to the Wiring Diagram on the previous page during this step. Wires from the ESC and servo will be routed beneath the small wire guides in this step. It is important to keep all loose wires carefully routed to avoid being damaged by the center driveshaft.

Step  
L-3

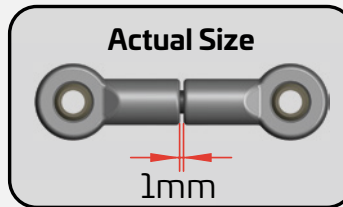

x2  
TKR1211  
M3 Lock Nut Flange Black

x2  
TKR1221  
M3x8mm Washer

x1  
TKR1325  
M3x14mm Flat Head Screw

x1  
TKR1327  
M3x16mm Flat Head Screw

x6  
TKR1341  
M4x6mm Flat Head Screw

x7  
TKR1401  
M3x6mm Button Head Screw

x1  
TKR1601  
M3x4mm Set Screw

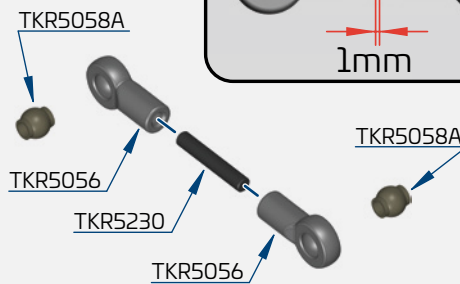

Step  
L-4

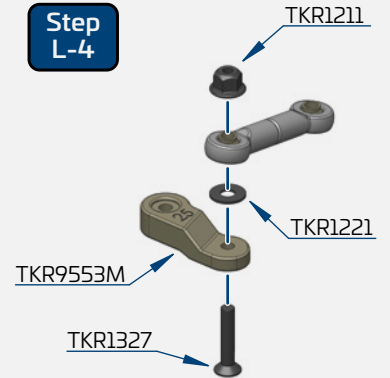

Step  
L-5

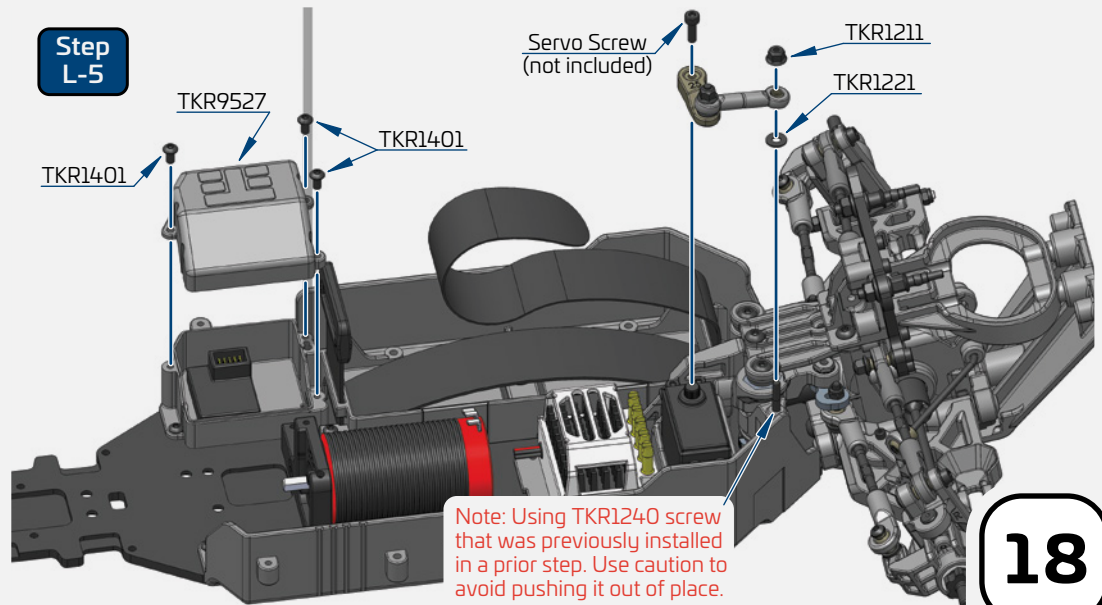

Note: Using TKR1240 screw that was previously installed in a prior step. Use caution to avoid pushing it out of place.

# Bag M

## Center Diff/ Rear End

Step  
M-1

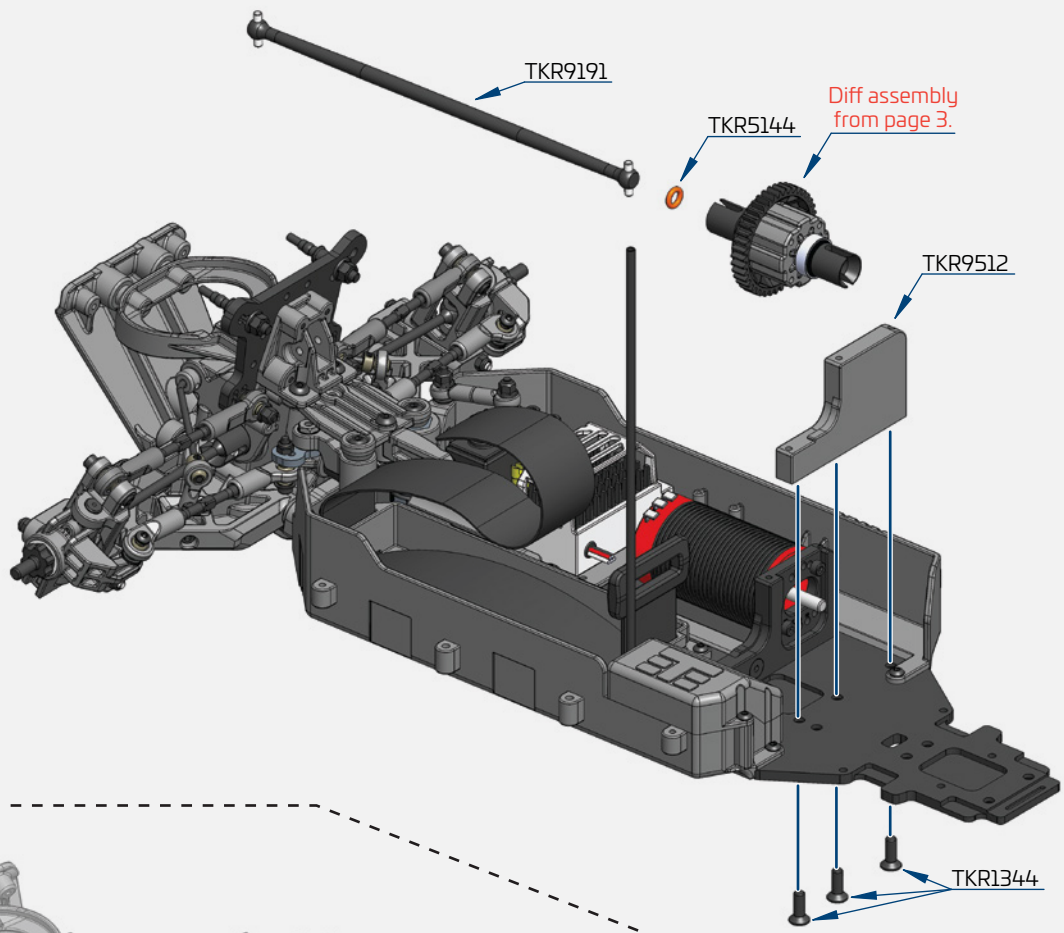

Step  
M-2

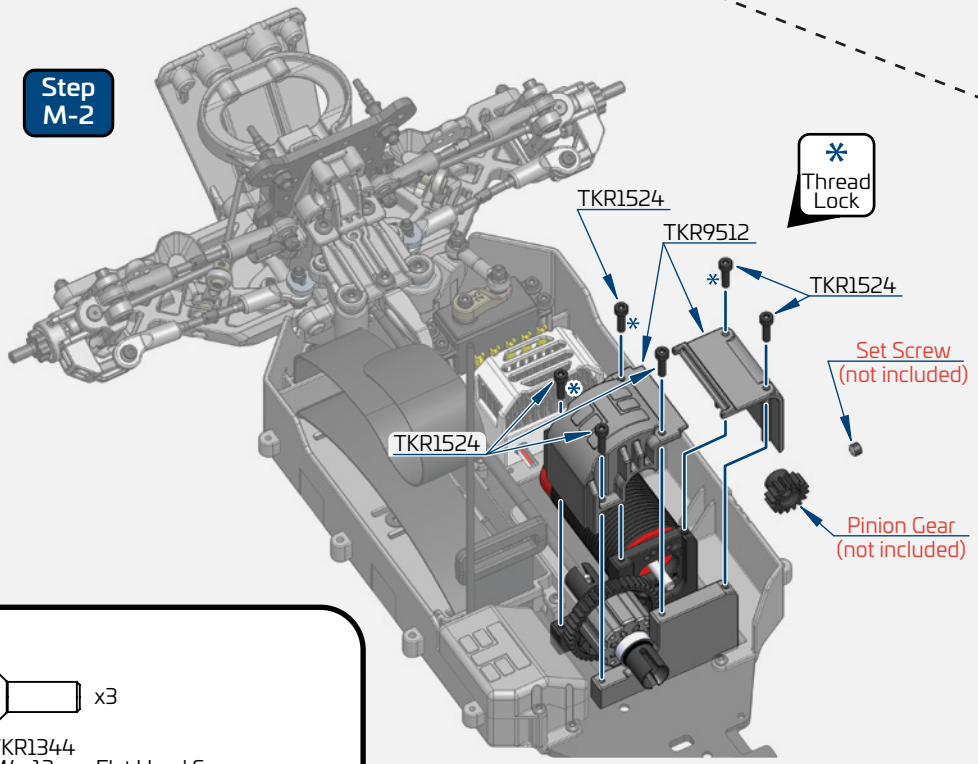

Step  
M-3

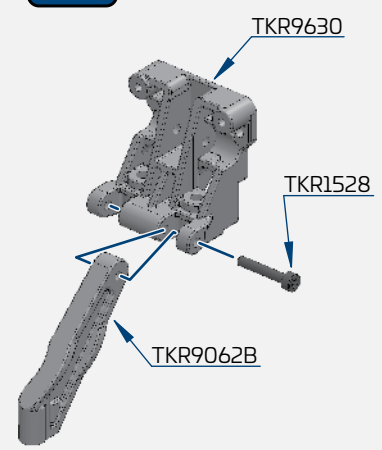

### TKR9585 - Optional Center Brace

(all parts can also be purchased separately)

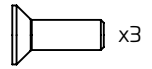
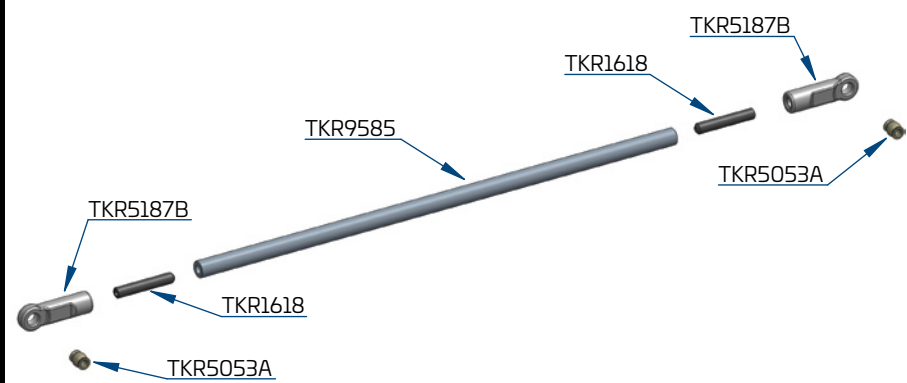

x3  
TKR1344  
M4x12mm Flat Head Screw

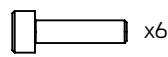

x6  
TKR1524  
M3x12mm Cap Head Screw

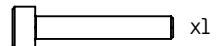

x1  
TKR1528  
M3x18mm Cap Head Screw



x1  
TKR5144  
Differential O-rings







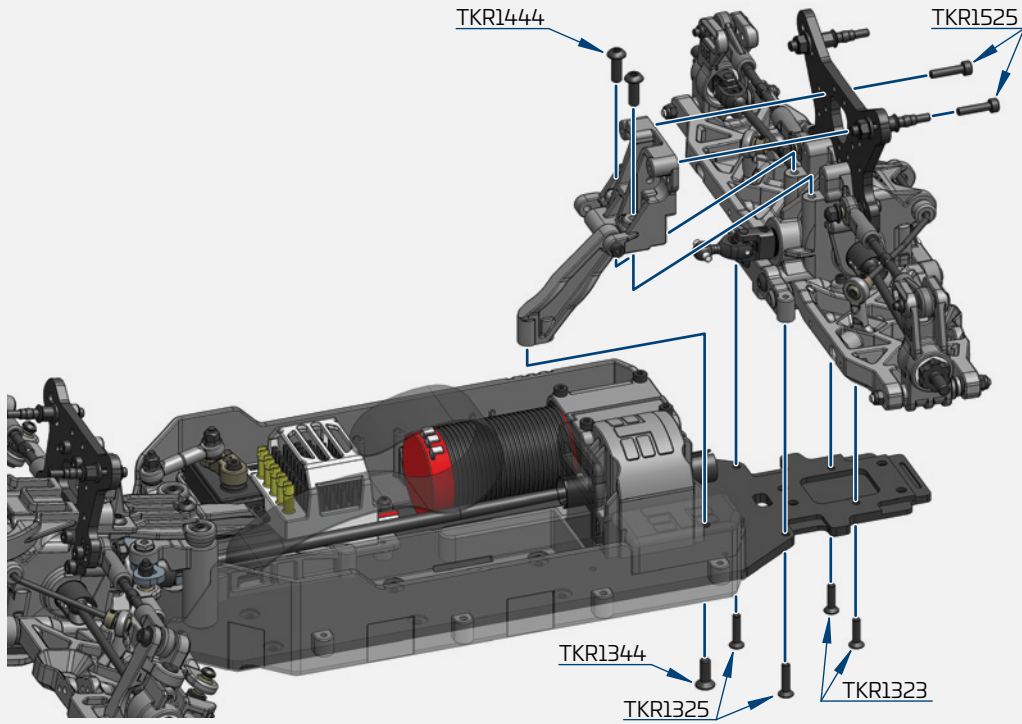

# Bag M

## Rear End

### Step M-4



### Step M-5

-  x2  
TKR1323  
M3x10mm Flat Head Screw
-  x2  
TKR1325  
M3x14mm Flat Head Screw
-  x1  
TKR1344  
M4x12mm Flat Head Screw
-  x2  
TKR1346  
M4x15mm Flat Head Screw
-  x2  
TKR1350  
M4x25mm Flat Head Screw
-  x2  
TKR1444  
M4x12mm Button Head Screw
-  x1  
TKR1445  
M4x14mm Button Head Screw
-  x2  
TKR1525  
M3x14mm Cap Head Screw
-  x2  
TKR1528  
M3x18mm Cap Head Screw

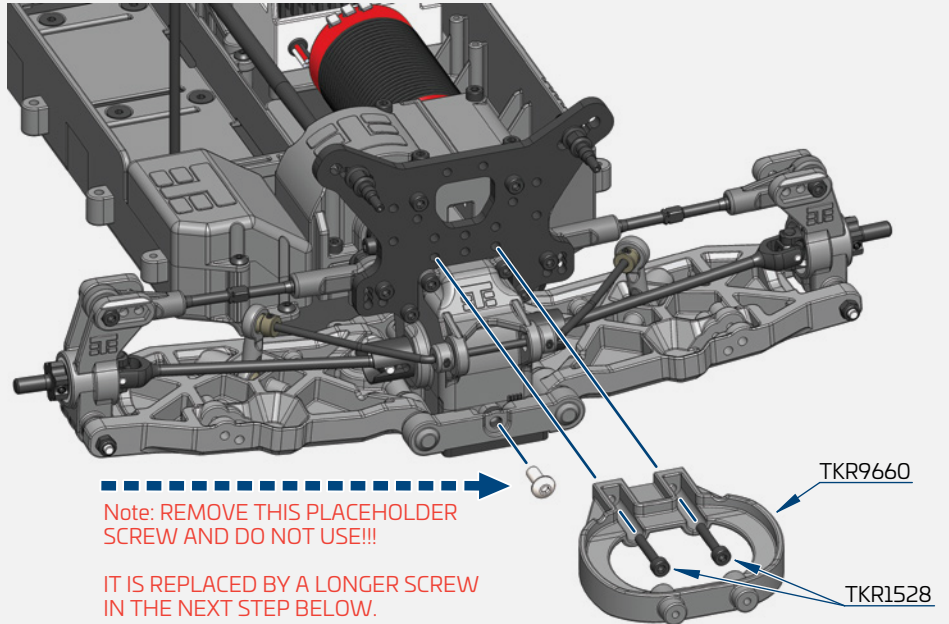

### Step M-6

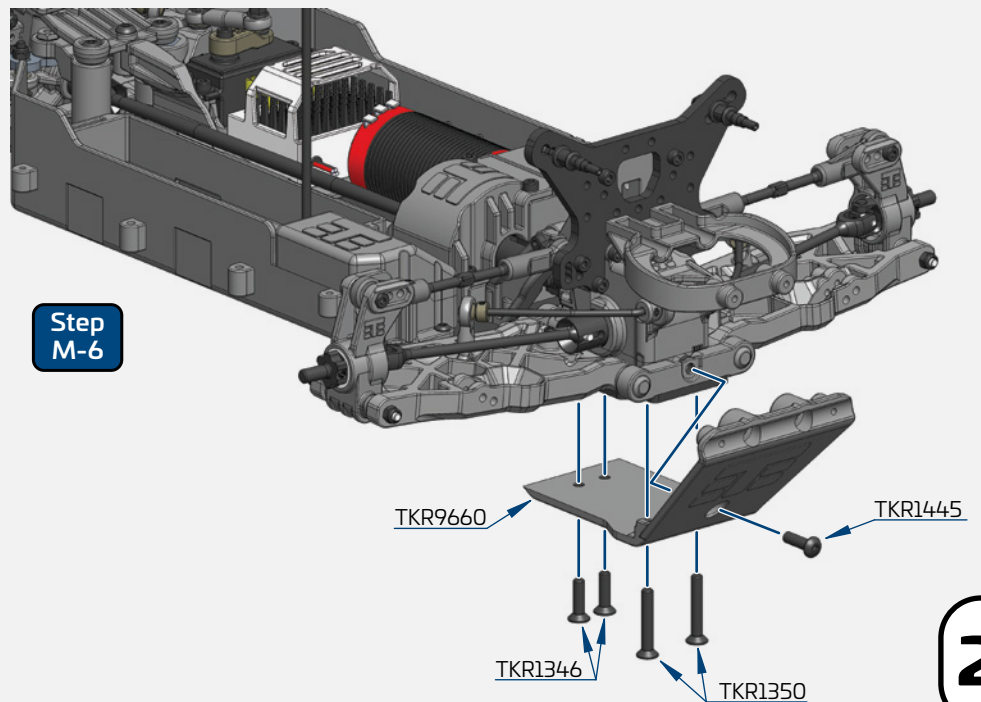

# Bag N Front Shock Assembly

## Step N-1

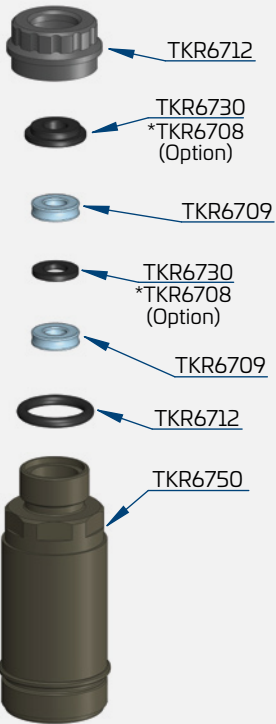
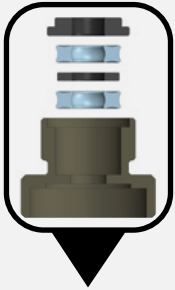

## Step N-2



## Step N-3



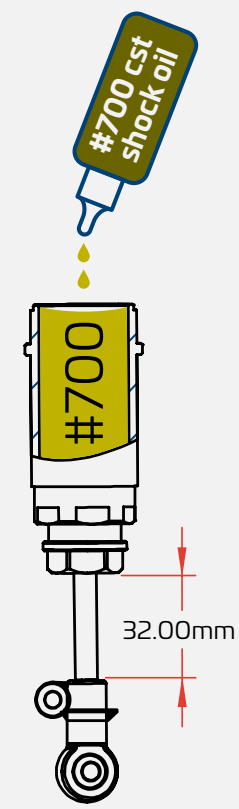

Refer to filling instructions on page 23 during this step.

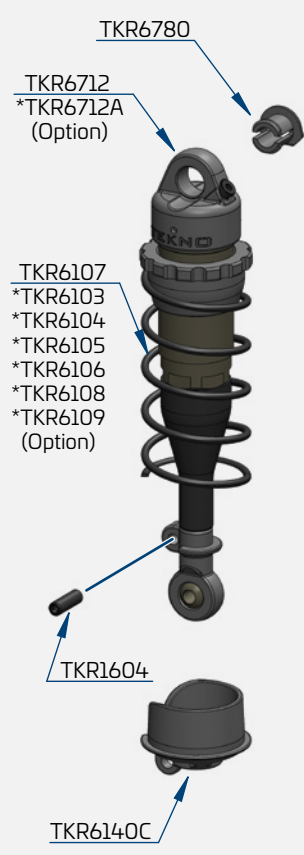

Note: Screw rod end on until distance measures 32mm at full extension.

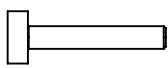
## Step N-4



-  x2  
TKR1211  
M3 Lock Nut Flange Black
-  x2  
TKR1240  
M3x18mm Shock Mnt Screw
-  x2  
TKR1248  
M2x4mm Emulsion Screw
-  x2  
TKR1265  
M2x6mm Emulsion Screw
-  x2  
TKR1266  
M2.5x5x.5mm Washer
-  x2  
TKR1604  
M3x8mm Set Screw

## Step N-5

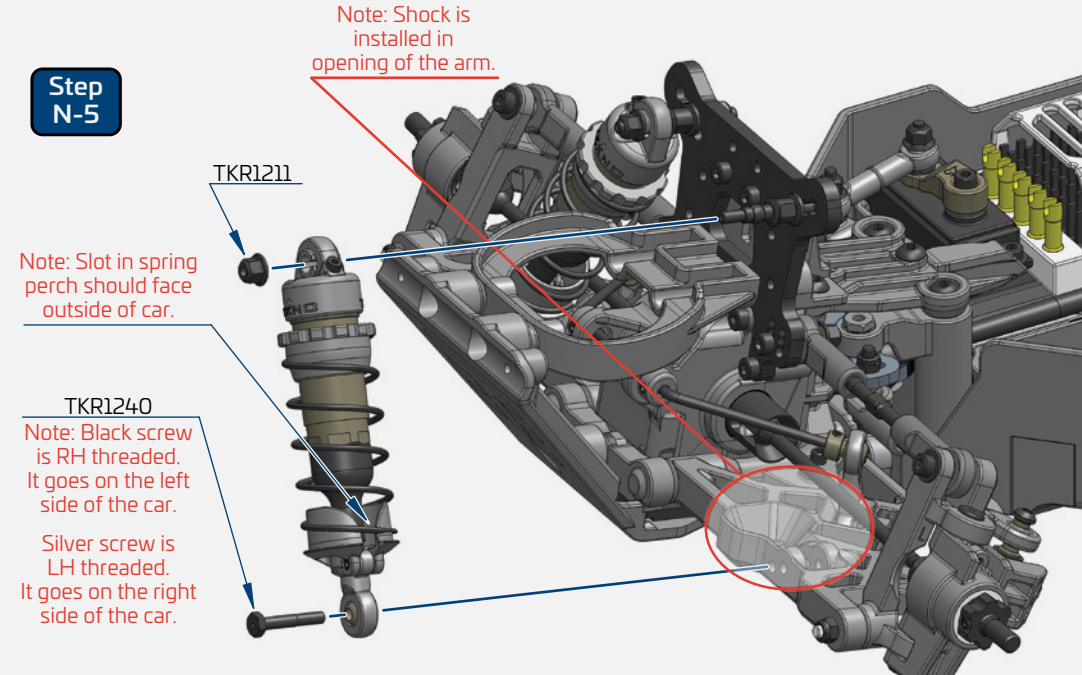

- Stock shock position is second front inside hole on the tower and inside hole on the arm (2/B)
- Shock length (droop) is 98mm
- Stock front ride height is 24mm

# Bag 0 Rear Shock Assembly

## Step 0-1

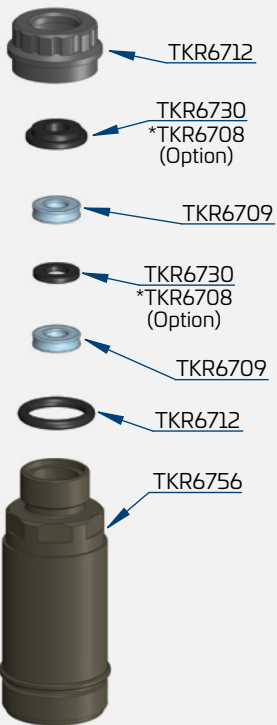
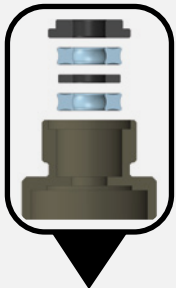

## Step 0-2

\* Thread Lock



Note: 1.1mm piston with writing up.

Note: Use green slime or oil on shock shaft threads AND O-rings to prevent tearing and leaking.

## Step 0-3

Refer to filling instructions and oil recommendation on page 23 during this step.

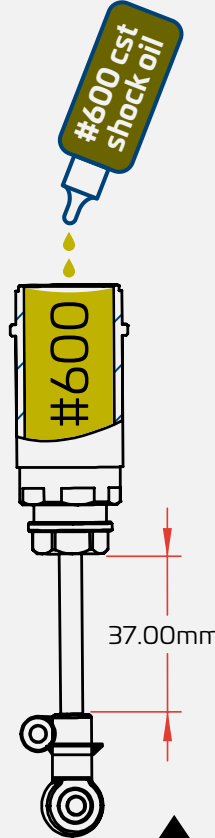

Note: Screw rod end on until distance measures 37mm at full extension.

## Step 0-4

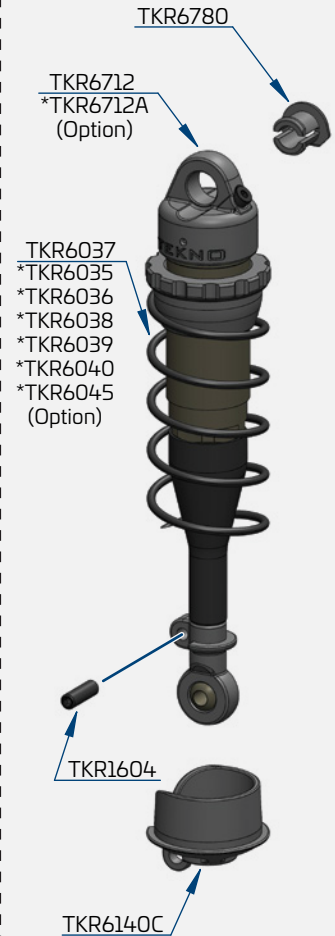

x2  
TKR1211  
M3 Lock Nut Flange Black

x2  
TKR1240  
M3x18mm Shock Mnt Screw

x2  
TKR1248  
M2x4mm Emulsion Screw

x2  
TKR1265  
M2x6mm Emulsion Screw

x2  
TKR1266  
M2.5x5x.5mm Washer

x2  
TKR1604  
M3x8mm Set Screw

## Step 0-5

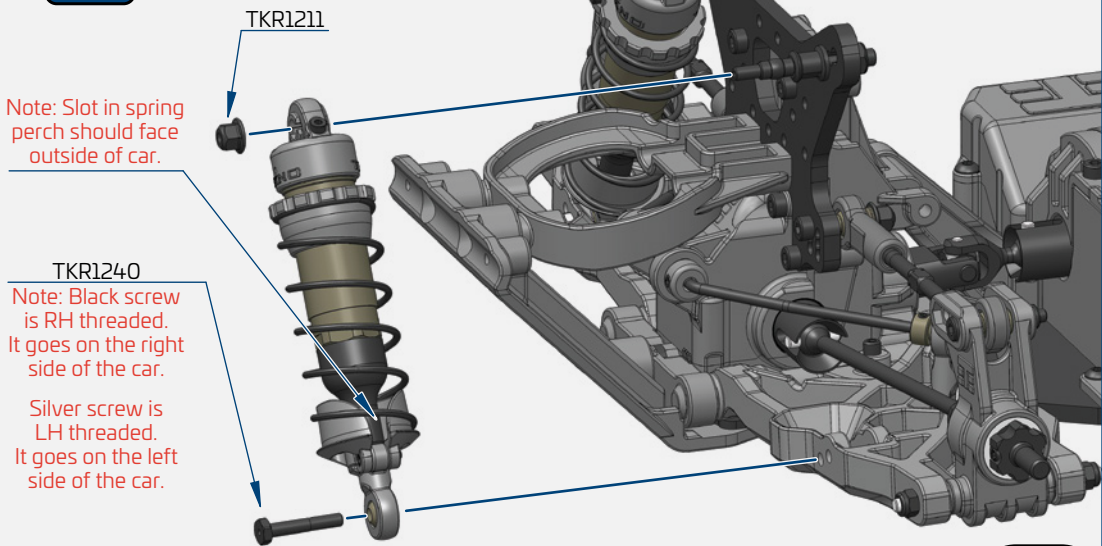

Note: Slot in spring perch should face outside of car.

TKR1240  
Note: Black screw is RH threaded. It goes on the right side of the car.

Silver screw is LH threaded. It goes on the left side of the car.

● Stock shock position is second from inside hole on the tower and inside hole on the arm.

● Shock length (droop) is 108mm  
● Stock rear ride height is 24mm

# Shock Filling Instructions

## For both front and rear shocks

We've found it's easiest to complete steps 1 & 2 on each shock before moving on to step 3. By the time you've finished step 2 on the last shock, the first one will be ready for step 3.

**Step 1.** Start by drilling out the emulsion hole if necessary. Use a 1/16th (or 1.6mm) drill bit to drill all the way through and clear any flashing created by this. Insert the four larger o-rings into the emulsion caps and set aside. Install the small o-rings onto the small emulsion screws (TKR1248).

**Step 2.** Fill shock with oil all the way to the top and pump the shock shaft up and down 3-5 times.

**Step 3.** Screw on the cap all the way tight (shock tool TKR1115 is helpful for holding the shock body). Be careful to not cross-thread the caps. Start by turning in the opposite direction before tightening.

**Step 4.** With the shock at about a 45° angle, push and hold the shock shaft to the top of the stroke. Oil should leak out during this process. If it does not, remove the shock cap and add more oil before continuing. Insert the prepared emulsion screw/seal. Tighten the screw until snug (do not over-tighten). Wipe off excess oil before moving on to step 5.

**Step 5.** Pump the shock shaft up and down about 20 times vigorously. This emulsifies the oil.

**Step 6.** With the shock shaft fully extended, remove the emulsion screw from the cap to do the final bleed.

**Step 7.** With the shock at about a 45° angle, push and hold the shock shaft to the top and insert the prepared emulsion screw/seal again. Oil will leak out during this process. Finish by tightening the screw until snug (do not over-tighten).

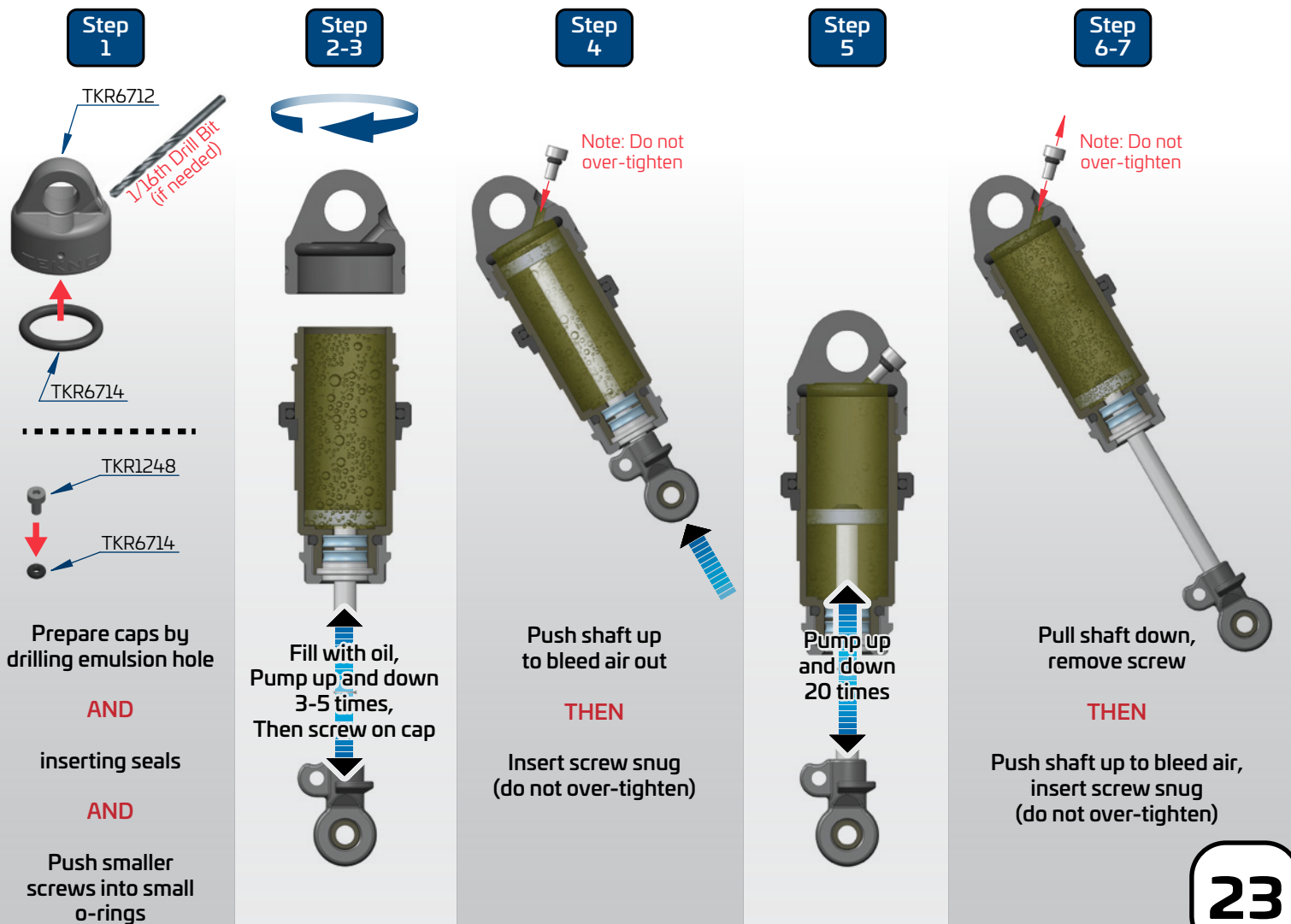

# Bag P

## Body Mounts

### Front/Rear Body Mounts

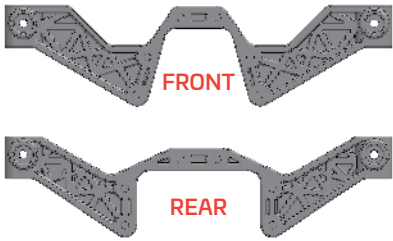

### Front/Rear Body Posts

Note: Lower the body posts as far as possible without having tire rubbing issues with the body during full uptravel.

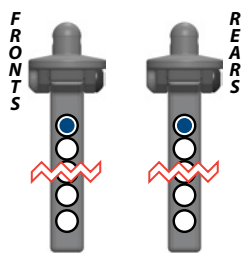

Note: When using lower body post hole positions, the bottom of the post will need to be trimmed to clear the camber links during uptravel.

### Step P-1

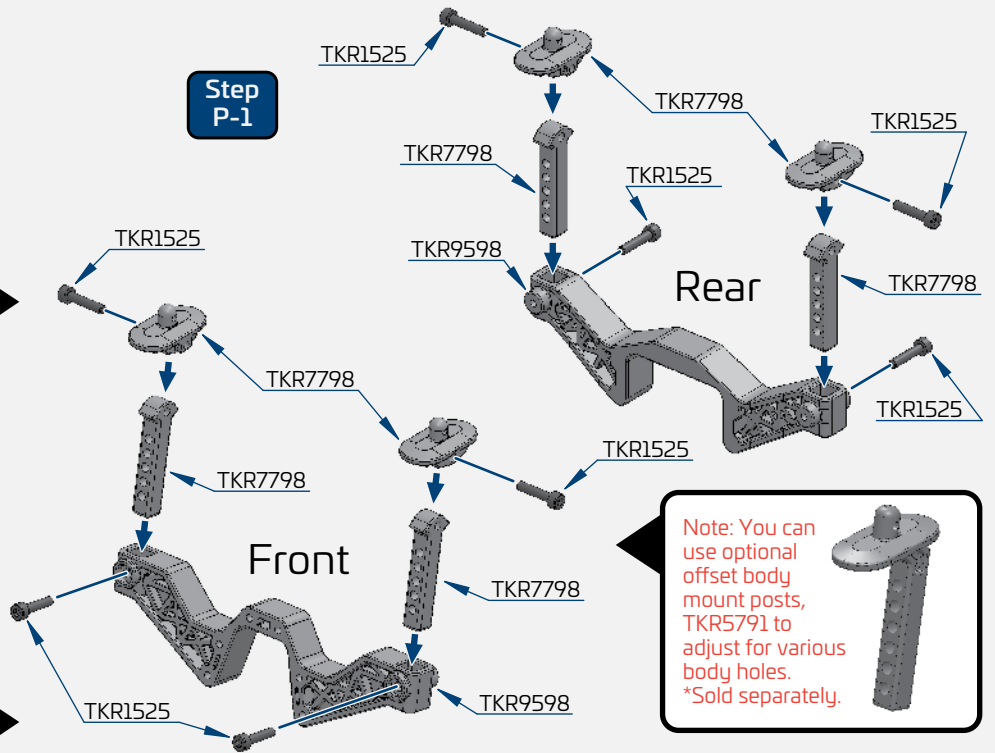

### Step P-2

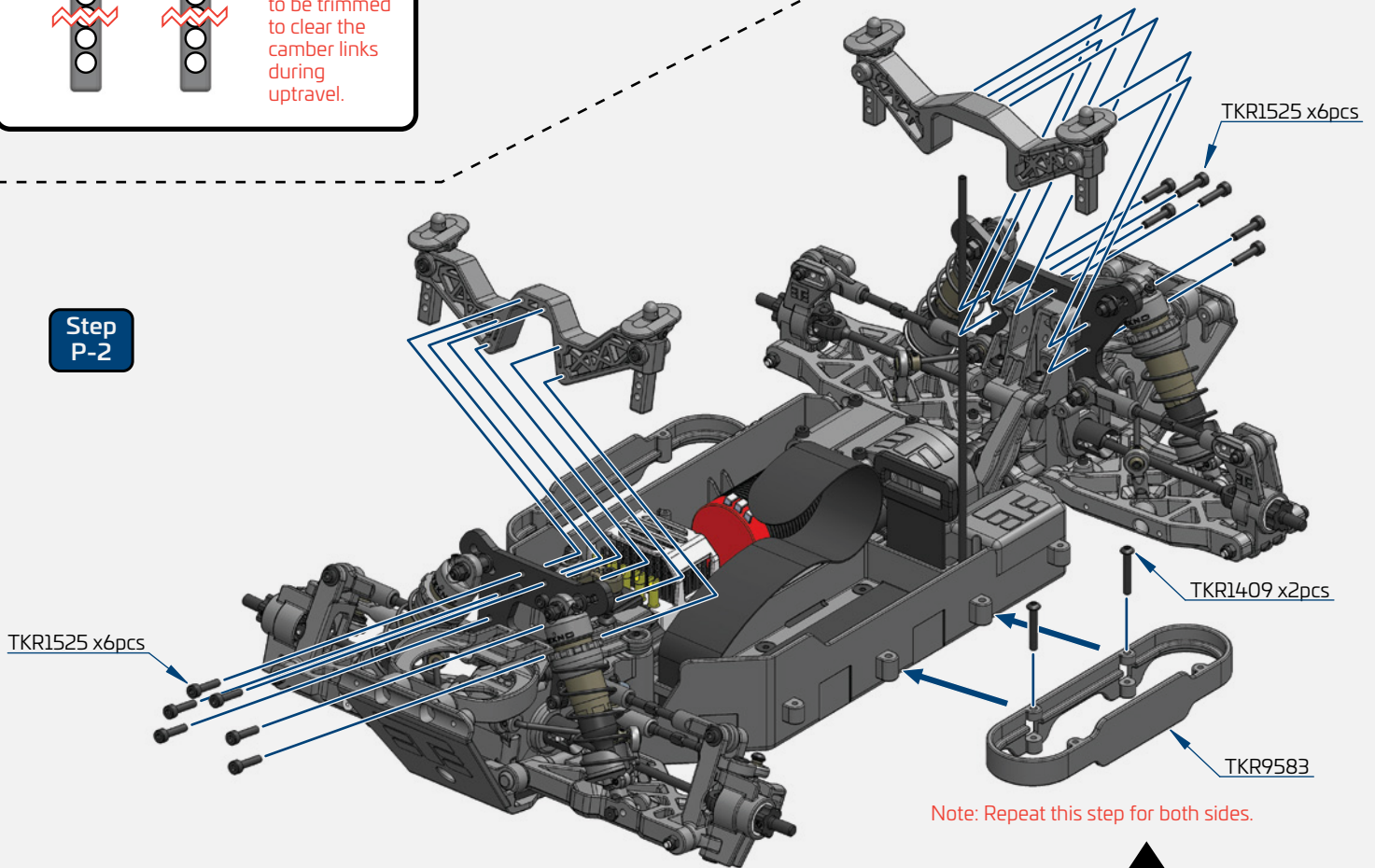

x20  
TKR1525  
M3x14mm Cap Head Screw

x4  
TKR1409  
M3x20mm Button Head Screw

### Optional Air Control Guards (TKR9584 - NOT INCLUDED)

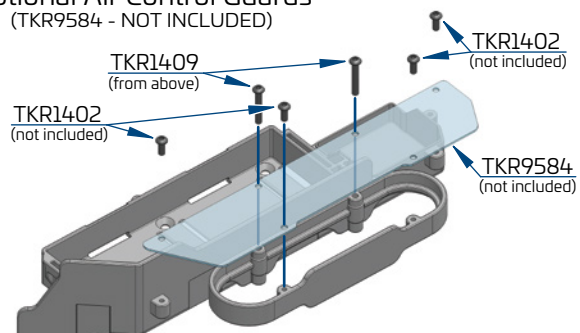

# Bag P

## Final Assembly

Step P-3

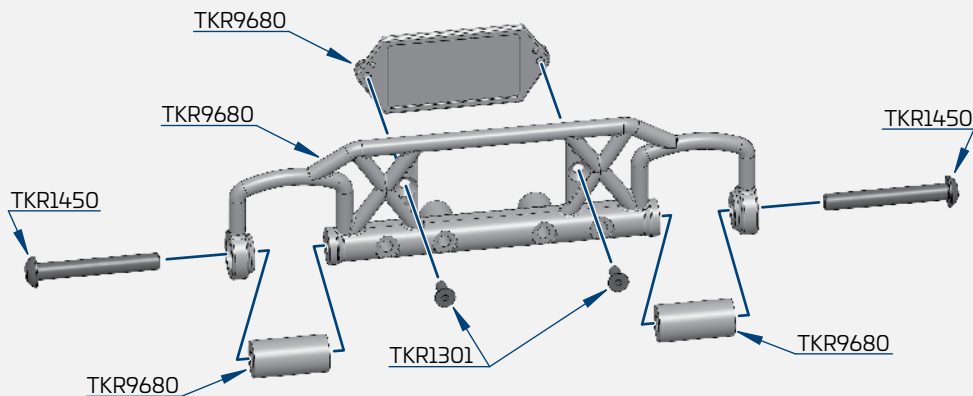

Step P-4

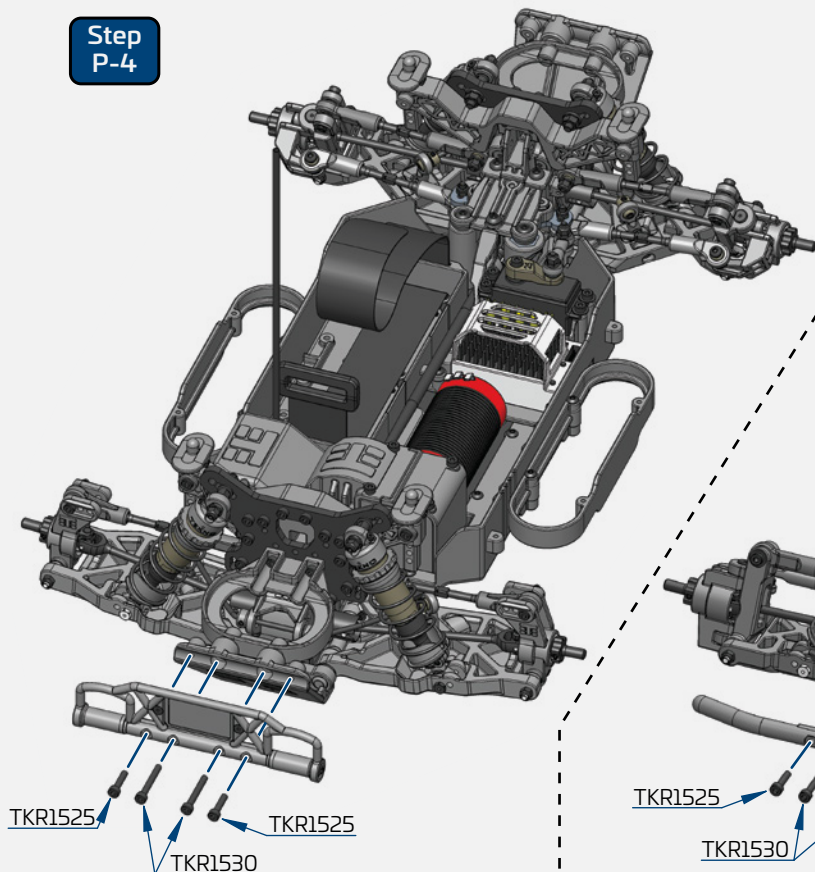

Step P-5

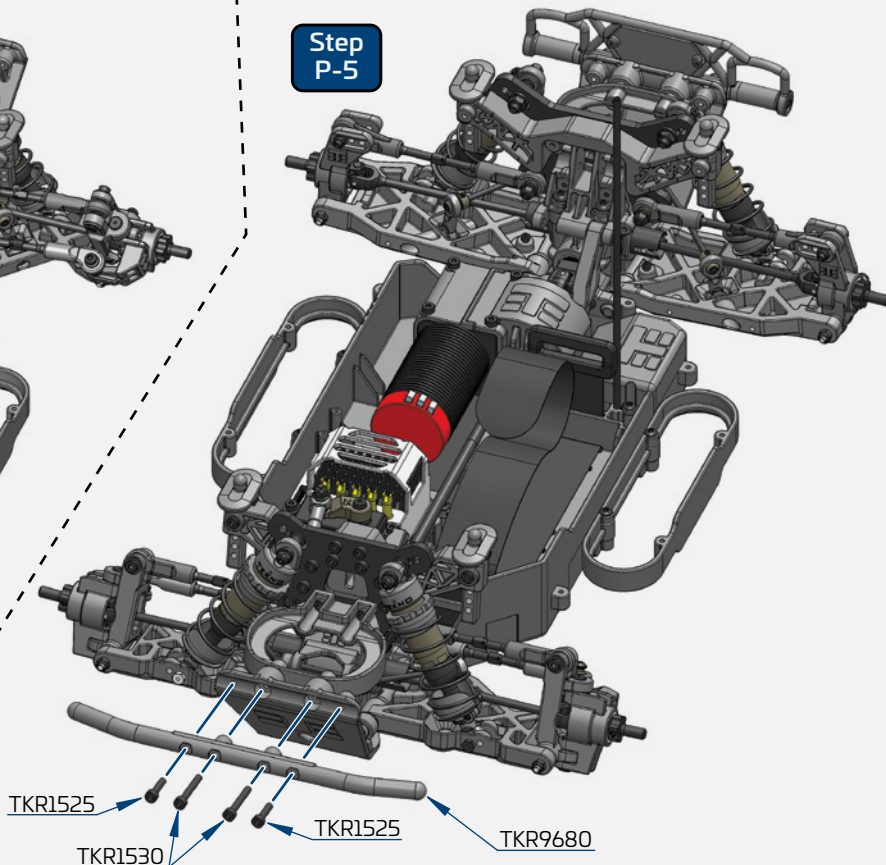

Step P-6

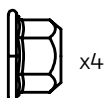

TKR1214  
M5 Lock Nut Flange



TKR1301  
M2.5x6mm Flat Head Screw

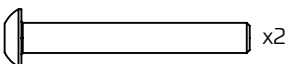

TKR1450  
M4x30mm Button Head Screw

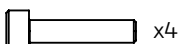

TKR1525  
M3x14mm Cap Head Screw

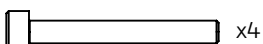

TKR1530  
M3x25mm Cap Head Screw

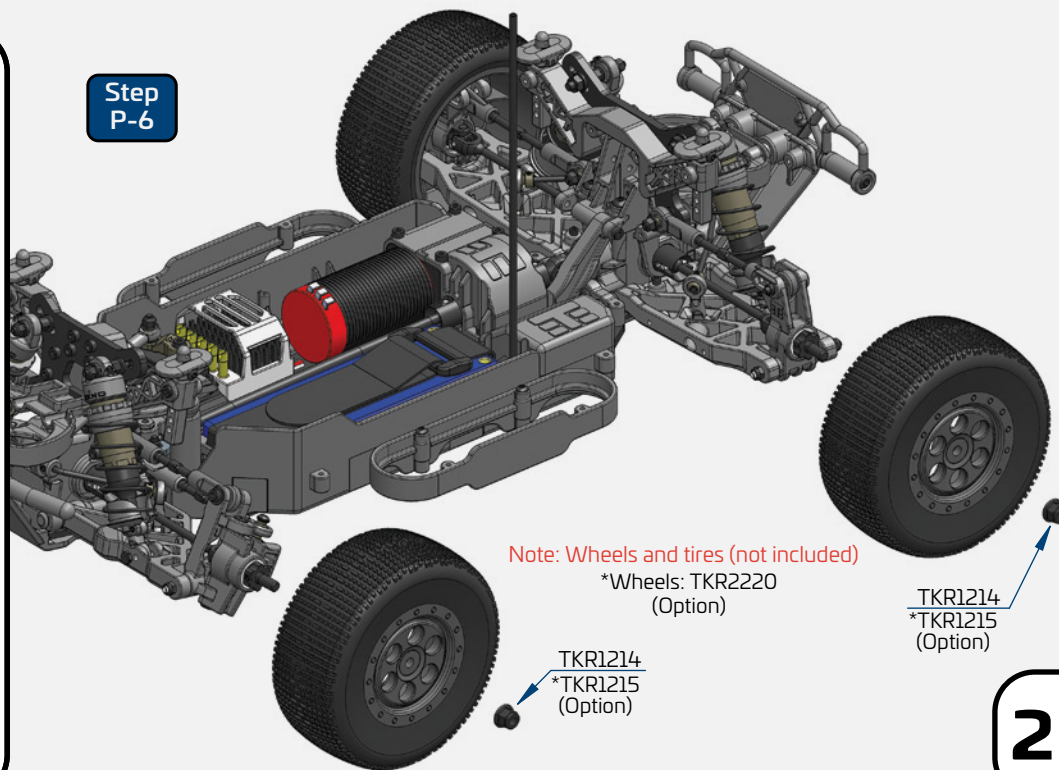

Note: Wheels and tires (not included)

\*Wheels: TKR2220  
(Option)

TKR1214  
\*TKR1215  
(Option)

TKR1214  
\*TKR1215  
(Option)

# TKR9500 - SCT410 2.0 1/10th 4x4 Short Course Truck Kit

## Parts List

TKR5049A - Pivot Balls (6.8mm, no flng, sway bar, shck ends, almmn, 4pcs)  
TKR5053A - Pivot Balls (6.8mm, flanged, outside camber, aluminum, 4pcs)  
TKR5056 - Rod Ends (brake/steering/sway bay linkage, 16pcs)  
TKR5058A - Pivot Balls (5.8mm, no flange, brake/steering link, aluminum, 4pcs)  
TKR5075HD - Diff Coupler (HD, hardened steel)  
TKR5079A - Stabilizer Balls (6.8mm, sway bars, aluminum, 4pcs)  
TKR5101X - Servo Saver Spring (HD, EB48, SCT410, NB48)  
TKR5103 - Servo Saver Post (aluminum, gun metal ano)  
TKR5126 - Antenna tube (universal, w/ caps, 5pcs)  
TKR5144 - Differential O-Rings (6pcs)  
TKR5188B - Rod Ends (hard, 6.8mm, M4 thread, SCT/SL, 8pcs)  
TKR5230 - Steering Linkage (M3x18mm threaded rod, 10pcs)  
TKR5231 - Servo Saver Nut and Spring  
TKR5571M - Wheel Hexes (steel w/ set screw, lightened, 12mm, SCT410/SL)  
TKR7798 - Body Post Set (swivel, 4pcs)  
TKR8052A - Pivot Balls (6.8mm, camber, str links, almmn, centered, 4pcs)  
TKR9017 - Sway Bar and Bulkhead Acc (2.0)  
TKR9017B - Sway Bar and Bulkhead Acc (for -2/-4mm bulkheads)  
TKR9020 - Hinge Pins (inner, front/rear)  
TKR9062B - Chassis Brace Set (revised, front/rear/center, EB/ET48 2.0)  
TKR9095 - Universal Driveshaft (center, rear, 17mm, EB48 2.0)  
TKR9102A - Steering Posts (aluminum, gun metal ano)  
TKR9191 - Tapered Driveshaft (center, front, 7075, black ano, EB/ET48 2.0)  
TKR9217 - Gearbox (0mm offset, fits TKR5113/5113B diffs)  
TKR9218 - Gearbox (-4mm offset, fits TKR5113/5113B diffs)  
TKR9508 - Chassis (4mm, black ano, SCT410 2.0)  
TKR9510 - Motor Mount (CNC, 7075, SCT410 2.0)  
TKR9512 - Center Differential Mount and Cover (MT/SCT410 2.0)  
TKR9514 - Battery Strap (1x center, for standard 2s or shorty 4s packs, all 2.0)  
TKR9515 - Suspension Arms (rear, MT/SCT410 2.0)  
TKR9516 - Suspension Arms (front, MT/SCT410 2.0)  
TKR9517 - Bell Cranks and Top Plates (MT/SCT410 2.0)  
TKR9521 - Ackerman Plate (7075, MT/SCT410 2.0)  
TKR9523 - Turnbuckle (M4 thread, 55mm length, 4mm adjustment, 2pcs)  
TKR9525L - Mud Guard, Battery Tray, RX Box (left, SCT410 2.0)  
TKR9525R - Mud Guard, Servo Mount (right, SCT410 2.0)  
TKR9527 - ESC Tray, Radio Box Top (MT/SCT410 2.0)  
TKR9534 - Hinge Pins (outer, F/R, MT/SCT410, 2pcs)  
TKR9541 - Spindles (L/R, MT/SCT410 2.0)  
TKR9542 - Spindle Carriers (L/R, MT/SCT410 2.0)  
TKR9543 - Spindle Pin Set (short/long, MT/SCT410 2.0)  
TKR9545 - Rear Hubs (L/R, MT/SCT410 2.0)  
TKR9546 - Decal Sheet (SCT410 2.0)  
TKR9550 - Turnbuckle (M4 thread, 65mm length, 4mm adjustment, 2pcs)  
TKR9553M - Metal Servo Horn (25T spline)  
TKR9561 - Hinge Pin Brace Set (steel/composite, A/B/C/D, MT/SCT410 2.0)  
TKR9568 - Shock Tower (front, 7075, black ano, MT/SCT410 2.0)  
TKR9569 - Shock Tower (rear, 7075, black ano, MT/SCT410 2.0)  
TKR9577 - Sway Bar Set (FRONT, 2.1, 2.2, 2.3, 2.4, 2.5, MT/SCT410 2.0)  
TKR9583 - Nerf Bars (SCT410 2.0, L/R)  
TKR9587 - Universal Driveshaft Set (f/r, 87mm, MT/SCT410 2.0, 2 pcs)  
TKR9593 - Sway Bar Set (REAR, 2.1, 2.2, 2.3, 2.4, 2.5, MT/SCT410 2.0)  
TKR9598 - Body Mount Base Set (SCT410 2.0)  
TKR9630 - Tower Brace Set (F/R, MT/SCT410 2.0)  
TKR9660 - Skid Plate and Bumper Cushion (F/R, MT/SCT410 2.0)  
TKR9680 - Bumper Bar Set (F/R, MT/SCT410 2.0)

## Bearings List

TKRBB050825RS - Ball Bearing (5x8x2.5mm, rubber shielded, 4pcs)  
TKRBB05114 - Ball Bearing (5x11x4, 4pcs)  
TKRBB05145 - Ball Bearing (5x14x5, shielded, 4pcs)  
TKRBB06103 - Ball Bearing (6x10x3, 4pcs)  
TKRBB06135F - Ball Bearing (6x13x5, flanged, shielded, 4pcs)  
TKRBB08165 - Ball Bearing (8x16x5, 4pcs)

## Shocks List

TKR6140C - Locking Shock Rod End and Spring Perch Set  
TKR6705E - Shock Piston Set (5x1.1, 5x1.2, flat/flat, 13mm, 4pcs)  
TKR6709 - Shock X-rings (8pcs, EB410)  
TKR6712 - Shock/Cartridge Cap & Bushing Set (4pcs each, EB410)  
TKR6721 - Shock Boots (medium, for 13mm shocks, 2pcs)  
TKR6722 - Shock Boots (long, for 13mm shocks, 2pcs)  
TKR6730 - Shock Adjustment Collar and Guide Set (for 16mm springs, 13mm shocks)  
TKR6750 - Shock Body (44.5mm, aluminum, hard ano, 2pcs)  
TKR6756 - Shock Body (rear, aluminum, hard ano, ET410, 2pcs)  
TKR6762 - Shock Shafts (3.5mm OD, 52mm long, 3.5mm thread, 2pcs)  
TKR6763 - Shock Shafts (3.5mm OD, 57mm long, 3.5mm thread, 2pcs)  
TKR8727 - Shock Standoffs (2pcs, requires TKR8730)  
TKR8730 - Shock Cap Bushings (4pcs, requires TKR8727)

## Differential List

TKR5113B - Differential Case (f/c/r, composite, fits TKR5150/B, 3pcs)  
TKR5143 - Differential Seals (3pcs)  
TKR5144B - Differential O-Rings (6pcs)  
TKR5145B - Differential Shims (revised, 6x17mm, 6pcs)  
TKR5149X - Differential Cross Pins (composite, for 3 complete diffs)  
TKR5150B - Differential Gear Set (18/9T, for TKR5113/B, internal gears only)  
TKR5153M - Differential Ring Gear (40t, F/R, fits TKR5113/5113B, use with TKR5154M)  
TKR5154M - Diff Pinion (9t, F/R, use with TKR5153M)  
TKR9114HD - Differential Outdrives (HD, F/C/R, EB/ET48, MT/SCT410 2.0, 2pcs)  
TKR9532 - Spur Gear (41T, offset, composite, fits TKR5113/5113B)

## Hardware List

TKR1201 - M3 Locknuts (black, 10pcs)  
TKR1211 - M3 Locknuts (flanged, black, 10pcs)  
TKR1212 - M4 Locknuts (flanged, black, serrated, 10pcs)  
TKR1214 - M5 Locknuts (flanged, black, 10pcs)  
TKR1221 - M3x8mm Washer (black, 10pcs)  
TKR1222 - 13x16x.1mm Diff Shims (10pcs)  
TKR1226 - 5x7x.2mm shims (10pcs)  
TKR1235 - Body Clips (10pcs)  
TKR1238 - Droop Adjustment Screws (M4x10mm, 8pcs)  
TKR1240 - Lower Shock Mount Screws  
TKR1248 - M2x4mm Cap Head Screws (black, 10pcs)  
TKR1265 - M2x6mm Cap Head Screws (black, 10pcs)  
TKR1266 - M2x5.0x0.5mm Washer (black, 10pcs)  
TKR1301 - M2.5x6mm Flat Head Screws (black, 10pcs)  
TKR1323 - M3x10mm Flat Head Screws (black, 10pcs)  
TKR1324 - M3x12mm Flat Head Screws (black, 10pcs)  
TKR1325 - M3x14mm Flat Head Screws (black, 10pcs)  
TKR1327 - M3x16mm Flat Head Screws (black, 10pcs)  
TKR1341 - M4x6mm Flat Head Screws (black, 10pcs)  
TKR1343 - M4x10mm Flat Head Screws (black, 10pcs)  
TKR1344 - M4x12mm Flat Head Screws (black, 10pcs)  
TKR1346 - M4x15mm Flat Head Screws (black, 10pcs)  
TKR1350 - M4x25mm Flat Head Screws (black, 10pcs)  
TKR1401 - M3x6mm Button Head Screws (black, 10pcs)  
TKR1403 - M3x10mm Button Head Screws (black, 10pcs)  
TKR1408 - M3x18mm Button Head Screws (black, 10pcs)  
TKR1409 - M3x20mm Button Head Screws (black, 10pcs)  
TKR1443 - M4x10mm Button Head Screws (black, 10pcs)  
TKR1444 - M4x12mm Button Head Screws (black, 10pcs)  
TKR1445 - M4x14mm Button Head Screws (black, 10pcs)  
TKR1447 - M4x16mm Button Head Screws (black, 10pcs)  
TKR1450 - M4x30mm Button Head Screws (black, 10pcs)  
TKR1522 - M3x8mm Cap Head Screws (black, 10pcs)  
TKR1524 - M3x12mm Cap Head Screws (black, 10pcs)  
TKR1525 - M3x14mm Cap Head Screws (black, 10pcs)  
TKR1528 - M3x18mm Cap Head Screws (black, 10pcs)  
TKR1529 - M3x20mm Cap Head Screws (black, 10pcs)  
TKR1530 - M3x25mm Cap Head Screws (black, 10pcs)  
TKR1601 - M3x4mm Set Screws (black, 10pcs)  
TKR1603 - M5x4mm Set Screws (black, 10pcs)  
TKR1605 - M3x10mm Set Screws (black, 10pcs)  
TKR1609 - M3x3mm Set Screws (black, 10pcs)  
TKR1613 - M3x12mm Screw Pins (black, 10pcs)

## Option Parts

TKR1103 - Turnbuckle Wrench (4mm, 5mm, hardened steel)  
TKR1107 - XT Nut Driver (5.0mm, adjustable length, 4mm shank)  
TKR1108 - XT Nut Driver (5.5mm, adjustable length, 4mm shank)  
TKR1115 - Pivot Ball and Shock Multi-tool (aluminum)  
TKR1116 - 17mm Wheel Wrench, Shock Cap Tool  
TKR1119 - 5.5mm / 7.0mm Wrench (hardened steel)  
TKR1654X - 12mm Aluminum Wheel Hexes (aluminum, 4pcs)  
TKR2220 - TR606 SCT Wheel (black, SCT410 offset, 4pcs)  
TKR4176 - M5 Pinion Gear (16t, MOD1, 5mm bore, M5 set screw)  
TKR4177 - M5 Pinion Gear (17t, MOD1, 5mm bore, M5 set screw)  
TKR4178 - M5 Pinion Gear (18t, MOD1, 5mm bore, M5 set screw)  
TKR4179 - M5 Pinion Gear (19t, MOD1, 5mm bore, M5 set screw)  
TKR4180 - M5 Pinion Gear (20t, MOD1, 5mm bore, M5 set screw)  
TKR5113S - Differential Case (f/c/r, hardened steel, ET48/MT410)  
TKR5114XB - Differential Outdrives (front/rear, revised, lightened)  
TKR5122 - Steering Rack Bushings (aluminum, gun metal ano, 2pcs)  
TKR5145C - Differential Shims (keyed, 6x17mm, 6pcs)  
TKR5149 - Differential Cross Pins (6pcs, requires TKR5150 gears)  
TKR5149A - Differential Cross Pins (Aluminum, 6pcs, requires TKR5150 gears)  
TKR5150 - Differential Gear Set (6pcs, requires TKR5149 pins)  
TKR5151 - Differential Ring Gear (straight cut, CNC, 40t)  
TKR5152 - Diff Pinion (straight cut, 10T, CNC)  
TKR5253B - Aluminum Servo Horn (25t spline, M3 clamp, double hole arm)  
TKR5571A - Wheel Hexes (12mm, clamping, aluminum, 4pcs)  
TKR5791 - Body Mount Set (SCT410, front/rear)  
TKR6708 - Shock Cartridge Guide Set (CNC, Delrin, 8pcs, EB410/ET410)  
TKR6712A - Shock Caps (7075, emulsion, black ano, 2pcs)  
TKR9019 - Battery Straps (1x center, 1x side, EB/ET48 2.0)  
TKR9090A - Aluminum Sway Bar Collars (4pcs, EB/NB/ET/NT48 2.0)  
TKR9114 - Differential Outdrives (F/R NB/NT48 2.0, F/C/R EB/ET48 2.0, 2pcs)  
TKR9161B - Hinge Pin Brace (CNC, 7075, -1mm LRC, EB/NB48 2.1, A Block)  
TKR9162B - Hinge Pin Brace (CNC, 7075, -1mm LRC, EB/NB48 2.1, B Block)  
TKR9163B - Hinge Pin Brace Hinge Pin Brace (CNC, 7075, -1mm LRC, C Block)  
TKR9163C - Hinge Pin Brace (CNC, 7075, -2mm LRC, EB/NB48 2.1, C Block)  
TKR9164B - Hinge Pin Brace (CNC, 7075, -1mm LRC, EB/NB48 2.1, D Block)  
TKR9164C - Hinge Pin Brace (CNC, 7075, -2mm LRC, EB/NB48 2.1, D Block)  
TKR9568C - Shock Tower (front, carbon fiber, MT/SCT410 2.0)  
TKR9569C - Shock Tower (rear, carbon fiber, MT/SCT410 2.0)  
TKR9578 - Sway Bar Set (FRONT, 2.6, 2.7, 2.8, 2.9, 3.0, MT/SCT410 2.0)  
TKR9584 - Air Control Guards (SCT410 2.0, left, right)  
TKR9585 - Chassis/Shock Tower Brace (SCT410 2.0)  
TKR9594 - Sway Bar Set (REAR, 2.6, 2.7, 2.8, 2.9, 3.0, MT/SCT410 2.0)

# Setup Information

The purpose of making adjustments is to make the car go faster around the track, or to make it more controllable, or both if possible. A car that's easier to drive should produce lower, more consistent lap times. It will also inspire more confidence in the driver, which is always good when nerves start getting the best of you.

Before you start thinking about changing your car's setup, consider these two things: First, is the car in perfect working order? Be sure that all of the suspension components operate freely without excessive play, and that the car isn't tweaked. Binding and worn out parts will result in poor performance and inconsistent handling. Second, always consider tires before making other adjustments. Time spent trying to get the vehicle to work with the wrong tires mounted will be wasted time. Without the right tires, even a great setup won't be a winning setup.

## Ride Height

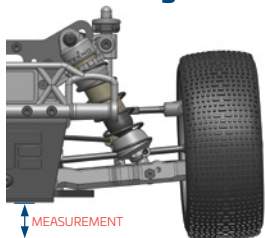

Ride height is the distance from the bottom of the chassis to the running surface. Ride height should only be checked and adjusted when your vehicle is ready to run (i.e. with battery installed/body on). Ride height is the first adjustment to be made and should be set with a ride height measurement tool. Measurements should be taken from the flat parts of the chassis, front and rear. Be sure to measure the front ride height at a point before the kick up in the chassis starts. To measure ride height, first make sure the suspension is completely free, then simultaneously compress the front and rear all the way down and let the vehicle settle. Take your measurement from that position. Use the shock spring adjustment collars to raise or lower the ride height to your desired setting. 24mm front and 24mm rear is a good starting point.

## Camber

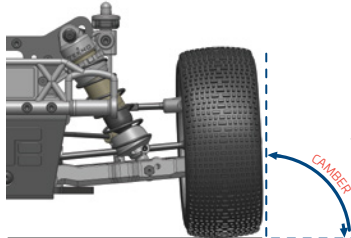

Static camber affects the car's side to side traction. More negative camber front and rear quickens rotation in corners. Less negative camber will make the vehicle easier to drive but you may give up some responsiveness (i.e. steering). To set your static camber have your vehicle at ride height (see above) and adjust the camber links until desired angle is achieved. Please note that a large adjustment of front camber will affect front toe and you may have to readjust the toe and then re-check front camber again. A good starting measurement for camber is 1-2 degrees in the front and 1.5-2.5 degrees in the rear.

## Front Toe

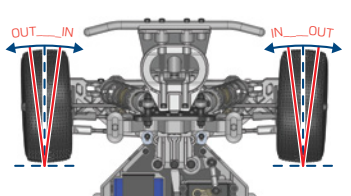

Front toe is used to describe the angle in which the front wheels point when looking down at them from the top of a vehicle. You will always use some amount of toe out. Toe-out will affect how your vehicle enters and exits corners. More toe out will result in more off-power steering and less on-power steering and less toe out will have the opposite results. To set your front toe, have your vehicle at ride height (see above) and adjust the steering links until desired angle is achieved. Please note that a large adjustment of front toe will affect front camber and you may have to readjust the camber and then re-check front toe again. A good starting point is approximately 0.5-1 degree of toe out per side.

## Ackermann Effect

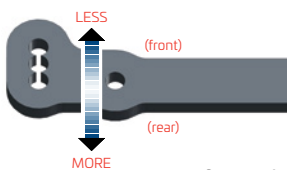

Think of Ackermann as active toe when the steering moves from left to right. More Ackermann effect makes more toe out at full turn. Less Ackermann effect makes less toe out at full turn. More Ackermann will be smoother and have less overall steering. Less Ackermann will feel more direct and have more overall steering.

A good starting point is forward on the Ackermann plate.

## Bumpsteer

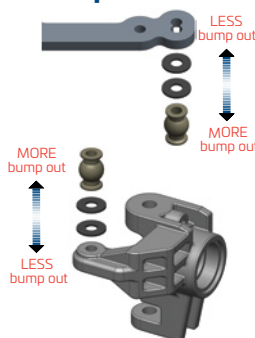

Think of bump steer as active toe when the suspension compresses or rebounds. To adjust bump steer you have to change the angle of the steering link. This is accomplished by adding or removing washers under the ball stud on the steering spindles. Anytime you change camber link locations, front arm pills, front arm spacers, or Ackermann you will need to check and possibly adjust your bumpsteer. It's best to start with zero bumpsteer or slight bump out.

## Droop

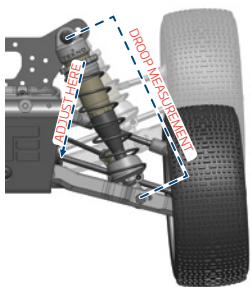

Droop is the measured amount of down travel in the suspension. It is measured from the shock mounting points while the vehicle is up on a stand allowing the arms to hang freely and is adjusted by turning the droop screw located in the suspension arms front/rear. This screw limits the suspension travel by providing a stopping point against the chassis. Left and right sides should always be equal, however the front and rear of the vehicle can have different values. Droop affects all aspects of chassis performance, including braking, acceleration, jumping, traction, and bump handling. A good starting droop measurement is 98mm front, and 108mm rear.

## C Block Screws



The C block now has the option to be screwed down to the chassis. This affects the torsional flex of the car as well as rear traction, both on and off power. With the screws in, there will be less torsional flex and more rear grip on power. With the screws out there will be more torsional flex and more rear grip off power. In almost all cases, running with the screws in provides better consistency and faster lap times.

# Setup Information

(continued)

## Differentials

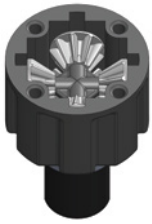

**Front:** Changing front diff oil affects overall steering response. Thinner can increase off-power steering but the vehicle may be twitchy and harder to drive. Thicker can increase on power steering and stability. We recommend 15k in the front diff.

**Center:** Changing center diff oil affects the front-to-rear drive balance. Thicker will reduce off-power steering and on-power rear traction but increases on-power steering and acceleration if traction is available. Thinner will increase off-power steering and on-power rear traction but reduce on-power steering and acceleration. We recommend 15k in the center diff.

**Rear:** Thinner rear diff oil increases off-power steering and reduces traction into a corner. It also reduces on-power steering and increases traction out of a corner. Going too thin will make your vehicle inconsistent, however. Thicker rear oil will have opposite effects, and once again, going too thick will make the vehicle inconsistent. We recommend 10k in the rear diff.

In addition to altering oils, there are other ways to affect differential action. First is by using different gear shims. TKR514-5B behaves like a normal shim and is included in the kit. It will have less resistance (compared to TKR514-5C) to both initial and continuous rotation. It will have a similar feel to thinner oil. This is beneficial on lower grip tracks. TKR514-5C is a static shim and will have more resistance to both initial and continuous rotation. It will have a similar feel to thicker oil. This is beneficial on higher grip tracks. This can also be good on tracks that are very rough and/or broken up and you want to maintain forward drive through bumpy sections. The second option is by using gears of a different pitch. TKR5150 is a finer pitch and TKR5150B is a coarser pitch gear. Finer pitch gears will have less resistance to continuous rotation. Being finer, the power delivery is smoother than the coarser pitch gears. The finer pitch will allow for a heavier weight oil to be used which will allow a thick but smooth low speed diff action without excessive differential action at high speeds and high loads. The coarser pitch will more resistance to continuous rotation. This means that it will resist "diffing out" or "diff unloading". Being coarser, the power delivery is not quite as smooth as the finer pitch gears. The coarser pitch will allow for a lighter weight oil to be used which will maintain low speed diff action without excessive differential action at high speeds and high loads. Third is by using different diff cases. TKR5113B will have similar characteristics of a static shim whereas TKR5113C will have the characteristics of the standard shim TKR514-5B. In addition, TKR5113C has a slightly greater volume so it should provide improved consistency over a long run.

## Rear Camber Links

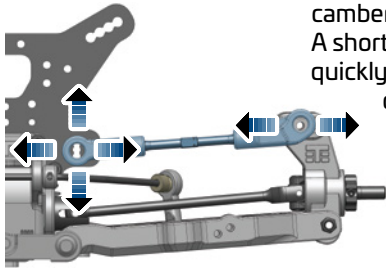

You can alter both the length and the angle of the rear camber link. When altering the length, a longer camber link will have more roll, more traction and forward drive, and will react slower to direction changes. A shorter link will have less roll and feel stiffer, have less traction and forward drive, and will react more quickly to direction changes. Link length also affects camber change throughout the suspension travel whereas shorter links will have more. Because of this it is typical to run slightly more static camber with long links and slightly less with short links to keep the camber in the ideal range for the suspension travel. When altering the link angle (less angle by going up on the tower or more angle by going down), less angle will have more roll, more grip in the turns, and react slower to direction changes. More angle will have less roll, will lose grip more suddenly, and react more quickly to direction changes.

## Front Camber Links

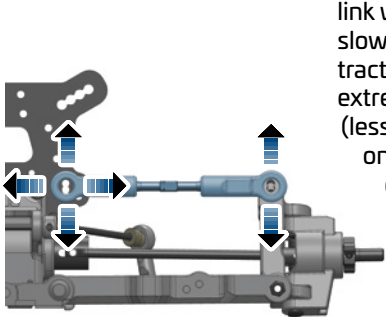

You can alter both the length and the angle of the camber link. When altering the length, a longer camber link will be more stable into turns, feel softer, have more overall traction and forward drive, and will react slower to direction changes. A shorter link feel stiffer, be more aggressive into turns, have more initial traction but less overall traction, and will react more quickly to direction changes. Unless you are on an extremely tight track the longer front link is recommended in all conditions. When altering the link angle (less angle by going up on the tower/down on the carrier or more angle by going down on the tower/up on the carrier), going to less angle will have more roll, more overall grip in the turns, and reacts slower to direction changes. Going to more angle will have less roll, more initial grip, and react more quickly to direction changes. Link angle will also affect camber gain during compression. Less angled links will have less camber gain throughout the suspension travel whereas more angled links will have more. Because of this it is typical to run slightly more static camber with long links and slightly less with short links to keep the camber in the ideal range for the suspension travel.

## Wheelbase Adjustments

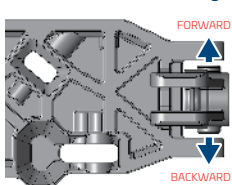

Changes to wheelbase can affect the overall handling of your vehicle, since it adjusts the distribution of weight on the wheels as well as the angle of the driveshafts. Shortening the wheelbase at the rear will give you more steering into a turn and off power, less steering out of a turn and on power. Lengthening the wheelbase at the rear will yield the opposite results. In general a longer wheelbase is better on open and/or bumpy tracks and a shorter wheelbase is better on tighter technical tracks.

## Springs

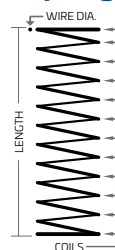

Softer springs will increase traction through the turns by allowing more roll, slow down the responsiveness of the vehicle, and can be better in the bumps. Stiffer springs will increase corner speed if traction is available and will also tend to jump and land better. Once you find a set of springs you like you will typically only change them for tracks with dramatically different conditions.

## Pistons



Pistons with smaller holes work well for smoother tracks with large jumps and pistons with larger holes work well for rougher tracks with less jumps. Smaller hole pistons will typically use thinner oil than larger hole pistons. Shock oil is also affected by the ambient temperature so a change in viscosity might be necessary with a change of 5°C or ~10°F.

## Sway Bars



Sway bars are used to adjust a vehicle's lateral grip by resisting chassis roll. A thicker bar decreases roll more than a thinner bar will. More roll means more grip and less roll means less grip. The front sway bar affects mainly off-power steering at corner entry. The rear sway bar affects mainly on-power steering and stability in mid-corner and at corner exit.

# Maintenance:

Performing regular maintenance will greatly improve your on track consistency and also extend the life of your vehicle. Going through critical areas of the vehicle regularly will also allow you to find possible issues before they become a problem that may cost you a race. Follow the guidelines below for maximum performance.

## Bearing Maintenance:

Bearings should always be smooth and free in order to perform their function. We recommend inspecting and cleaning each bearing on a regular basis. It will be necessary to break down parts of the vehicle in order to inspect them properly. The procedures below should be done every couple of weeks or prior to an important race.

1. Inspect the outer seals for any visible damage and check the rolling resistance of each bearing.
2. If any bearing does not spin freely, then take the following steps to clean them.
3. Spray the bearing with motor spray and spin it again to remove any debris trapped inside. Repeat if necessary. If the bearing does not start to spin freely after cleaning, then they may need to be replaced.
4. Allow the clean bearing to dry or blow into the bearing with compressed air to speed up the drying process.
5. Oil each bearing with a proper bearing lubricant. One or two drops is enough.

## Shock Maintenance:

When comparing the left and right shocks of the front end, they should feel identical. Same goes for the rears. The procedures below should be done every race day to make sure they are leak free and operating correctly.

1. After removing the shocks from the vehicle, remove the springs and inspect each shock for visible leaks (build up of debris at the bottom of the shock shaft or visible oil).
2. If the shock binds when pushing the shaft through its stroke, then the shaft may be bent and will need to be replaced.
3. If the shocks from left to right do not feel consistent when compared to each other, or have built up too much air inside (feel empty when pushing the shaft through its stroke), then you will need to rebuild them following the steps outlined on page 19 of this manual.

## Hinge Point & Drive Line Maintenance:

Checking the hinge points while the shocks are removed from the vehicle is the best time to inspect these parts. The other items to inspect are the camber links, steering links and drive shafts. Follow the steps below every couple of weeks in order to keep the vehicle performing at the maximum level.

1. With the shocks off the vehicle, check the movement of the arms, hubs, and spindle carriers. They should move freely. If there is a bind, then the inner or outer hinge pin may be bent and would need to be replaced. The arms should not have any play when twisted or moved in any direction against the hinge points. If there is excessive slop present, then the arms or hubs may be worn and will need to be replaced.
2. Remove the camber links, steering links and servo link from the vehicle. Check the movement of the spindles to see if they turn freely. If they don't, then check the kingpin shoulder screws to see if they are tightened down too far. Also, check for slop. If there is excessive slop present, then the spindle carriers may need to be replaced.
3. Check the steering rack to make sure it moves freely. If it binds, then the screws holding the Ackermann or the steering posts could be too tight. If they still bind, then check the bearings and follow the steps above to clean them.
4. After re-installing the camber links, steering links and servo link, check the movement of the rod ends on the ball studs. If they have excessive slop or are binding, then they may need to be replaced.
5. Check the drive shafts by rotating them. Look for any wobbles. If they are bent, replace them immediately.
6. With the drive shafts removed, check for slop in the CV area. If it is present, then reposition the CV pin to another fresh hole, re-lubricate and install back into the vehicle.

## Differential Maintenance:

Properly maintained differentials are essential for a smooth operating vehicle. Check all three diffs regularly to make sure they are filled and operating as designed.

1. Remove each diff and verify the differential action is happening and is smooth. If there is any notchy feel to them, follow the steps below to rebuild them.
2. Open the diff and pour out the oil. Remove the gears and pins to release the outdrives, then remove the seals. Inspect everything to make sure there are no damaged parts. If the seals are old or show any signs of degradation, replace them immediately. Re-lubricate the seals and outdrives, then rebuild the diff following the steps on page 3 and 4.

Name: Box Stock Date: \_\_\_\_\_ Event: \_\_\_\_\_ Ambient Temp: \_\_\_\_\_

Track: INDOOR  OUTDOOR  Size: SMALL  MEDIUM  LARGE  Traction: LOW  MEDIUM  HIGH

Surface: SMOOTH  BUMPY  RUTTED  Type: LOOSE / LOAMY  HARD PACKED  BLUE GROOVE  CLAY  ASTRO

## Ackerman/Bumpsteer/Servo Saver

Condition: DUSTY  DRY  WET  MUDDY



WASHERS:

2



FULL  
TURNS  
FROM  
FULLY  
TIGHT

## Front End:

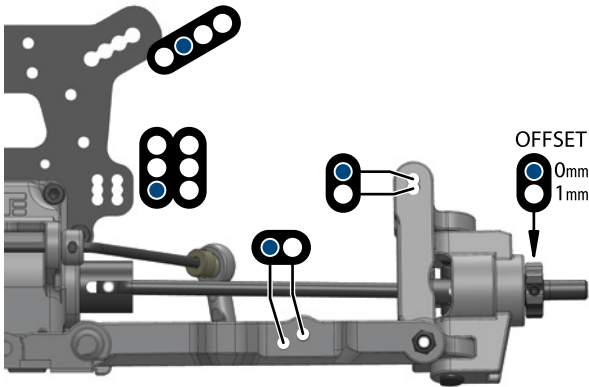

### Suspension:

RIDE HEIGHT: 24 CAMBER: -2°  
 CASTER BLOCK: 18° SWEEP: 0°  
 KICK UP: 10° TOE: 2.0° out  
 SWAY BAR: 2.1mm DROOP: 98mm

### Shocks:

OIL: 700 CST BRAND: Kit  
 PISTON: TKR6705E SPRING: TKR6107  
 REBOUND: 0% BUILD: emul

## Differentials:

OPTION	FRONT	CENTER	REAR
<b>Diff Oil</b>	15k	15k	10k
(TKR5145B)	<input type="radio"/>	<input type="radio"/>	<input type="radio"/>
(TKR5145C)	<input type="radio"/>	<input type="radio"/>	<input type="radio"/>
(TKR9114)	<input type="radio"/>	<input type="radio"/>	<input type="radio"/>
(TKR9114HD)	<input type="radio"/>	<input type="radio"/>	<input type="radio"/>
(TKR51114XB)	<input type="radio"/>	<input type="radio"/>	<input type="radio"/>
(TKR5150)	<input type="radio"/>	<input type="radio"/>	<input type="radio"/>
(TKR5150B)	<input type="radio"/>	<input type="radio"/>	<input type="radio"/>
(TKR5113B)	<input type="radio"/>	<input type="radio"/>	<input type="radio"/>
(TKR5113S)	<input type="radio"/>	<input type="radio"/>	<input type="radio"/>
(TKR5113)	<input type="radio"/>	<input type="radio"/>	<input type="radio"/>
(TKR5149X)	<input type="radio"/>	<input type="radio"/>	<input type="radio"/>
(TKR5149A)	<input type="radio"/>	<input type="radio"/>	<input type="radio"/>
(TKR5149)	<input type="radio"/>	<input type="radio"/>	<input type="radio"/>

## Rear End:

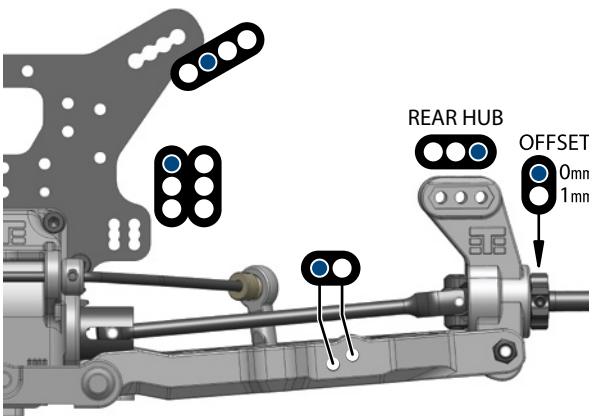

### Suspension:

RIDE HEIGHT: 24 CAMBER: -2°  
 ANTI-SQUAT: 1° TOE: 2.5°  
 SWAY BAR: 2.1mm DROOP: 108mm

### Shocks:

OIL: 600 CST BRAND: Kit  
 PISTON: TKR6705E SPRING: TKR6037  
 REBOUND: 0% BUILD: emul

## Drivetrain:

PINION/SPUR: / 41

## Equipment:

ESC: \_\_\_\_\_  
 BATTERY: \_\_\_\_\_  
 MOTOR: \_\_\_\_\_  
 SERVO: 250 oz/in minimum

## Wheelbase:

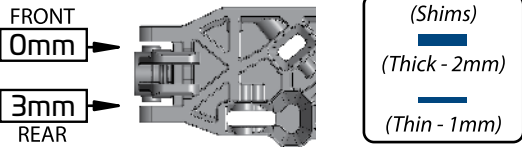

## Optional Hinge Pin Braces:

### "A" Block:

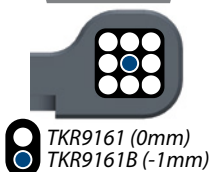

### "B" Block:

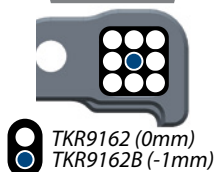

### "C" Block:

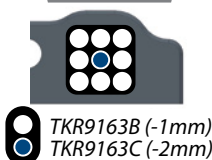

### "D" Block:

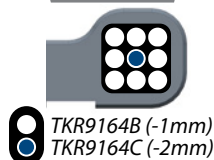

## Chassis Braces:

TURNBUCKLE BRACE:  CENTER BRACE:   
 REAR BRACE:

## Tires / Wheels:

BRAND / TREAD: \_\_\_\_\_  
 COMPOUND: \_\_\_\_\_  
 INSERT: \_\_\_\_\_  
 WHEEL: \_\_\_\_\_  
 NOTES: \_\_\_\_\_

## Body/Body Mounts:

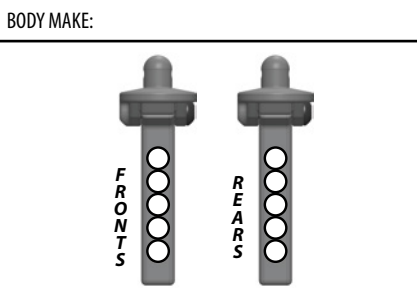

## Notes:

# General Warranty Information

Parts covered by our general warranty have a 50% MSRP replacement cost if bent, broken, or even worn out. See below for items covered by this warranty. Once the part(s) along with the completed warranty form is received and warranty eligibility is verified, we will send you a coupon code via e-mail that brings your price for the exact same replacement part to 50% of MSRP from our website (shipping not included).

## Items covered by warranty:

Only individual vehicle parts are covered. For example, kits, engines, engine parts, tools, apparel, banners, and canopies are not covered by the general warranty. Also, discontinued parts, parts that are no longer in production or are not for sale on this website are not covered by the general warranty.

## Conditions:

- Shipping to Tekno RC or to you will not be included in the coupon. You will be responsible for shipping the part, along with the completed warranty form to the address listed below. You will also be responsible for the shipping cost of the replacement part.
- You **MUST** send the part(s) to the address listed below. Pictures of the part are not sufficient.
- A completed warranty form **MUST** be included with all parts sent.
- The discount cannot exceed 50% from MSRP. If you already receive a discount (Team/Military), you will receive a coupon that reduces your cost of the part to 50% of MSRP.
- Coupons are valid for 14 days from the date of creation. If you do not purchase a replacement within this time, the coupon offer and warranty are void.
- This offer is **ONLY** valid at [www.teknorc.com](http://www.teknorc.com).
- Please be sure all customs fees have been paid. Tekno RC will refuse receipt of a package with customs fees due.
- Terms and conditions may change at any time without notice. Warranty policy may change at any time without notice. All warranties are subject to review and may be refused or revoked at our sole discretion at any time without notice. If any conditions or instructions above are not met, the warranty will not be processed, and no notice is required from us that your warranty may not be processed.

**USA** Tekno RC  
10755 Scripps Poway Pkwy #598  
San Diego, CA 92131  
U.S.A

**INT** Tekno RC Europe  
PO Box 67259  
Melissia, Athens 15102  
Greece

Full Name: \_\_\_\_\_

Address: \_\_\_\_\_

City: \_\_\_\_\_

State: \_\_\_\_\_

Zip: \_\_\_\_\_

Country: \_\_\_\_\_

Email: \_\_\_\_\_

Phone: \_\_\_\_\_

Part #(s) in question: \_\_\_\_\_  
\_\_\_\_\_  
\_\_\_\_\_  
\_\_\_\_\_  
\_\_\_\_\_  
\_\_\_\_\_

Signature: \_\_\_\_\_

Date: \_\_\_\_\_



Tekno RC  
10755 Scripps Poway Pkwy #598  
San Diego CA 92131  
USA

[www.teknorc.com](http://www.teknorc.com)  
[info@teknorc.com](mailto:info@teknorc.com)

