

Name: \_\_\_\_\_ Date: \_\_\_\_\_ Event: \_\_\_\_\_

Track Conditions: Outdoor  Indoor  Wet  Dry  High Bite  Low Bite   
 Rough  Smooth  Hard Packed  Loose/Loamy  Blue Groove

### Bumpsteer/Ackerman/Servo Saver:

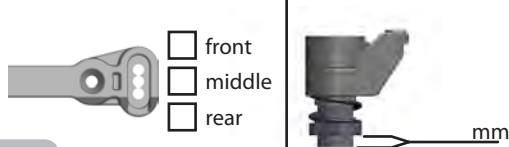
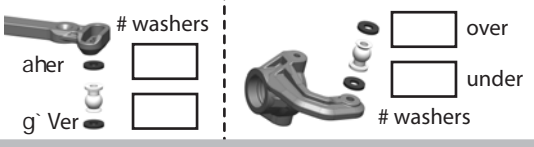

### Front End:

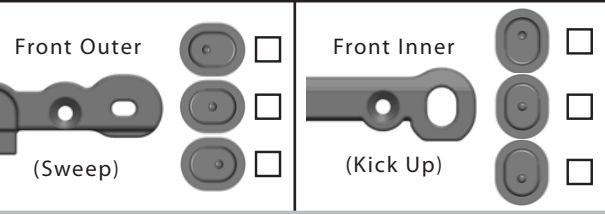
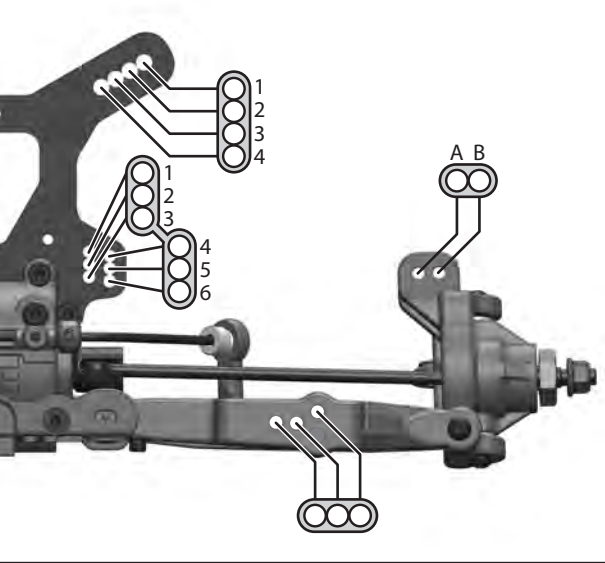

### Rear End:

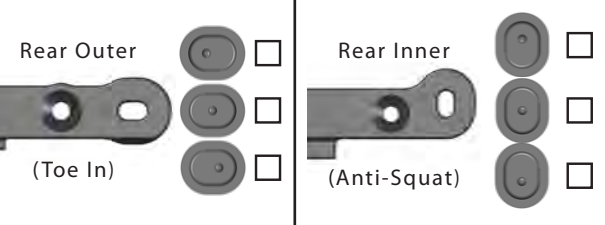
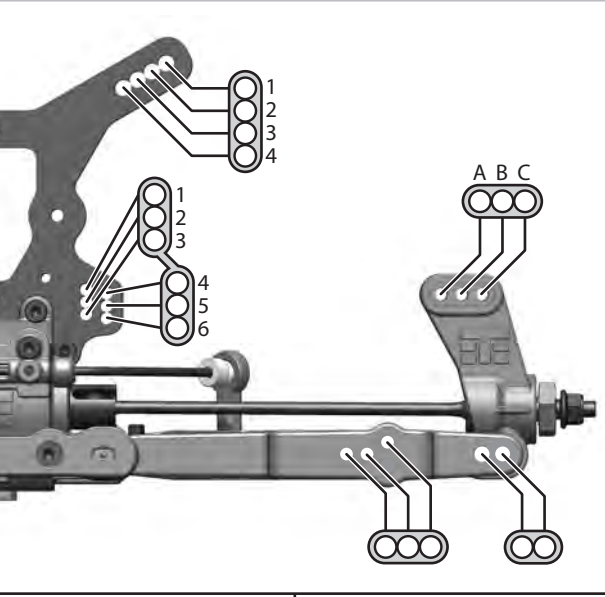

### Suspension:

	FRONT	REAR
RIDE HEIGHT		
CAMBER		
TOE (in/out)		
SWAY BAR		
SHOCK LENGTH (DROOP)		

### Body/Mounts:

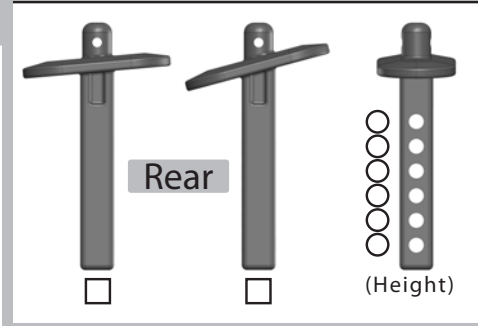
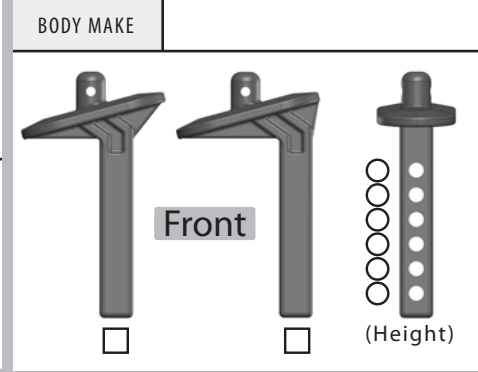

### Wheelbase:

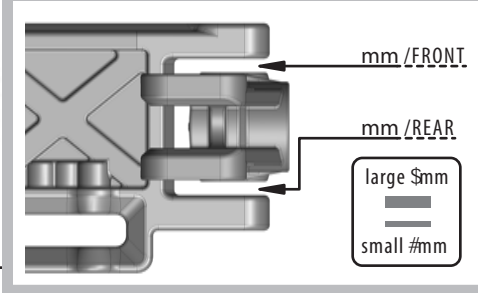

### Notes:

### Shocks:

	FRONT	REAR
OIL		
PISTON		
SPRING		
REBOUND	%	%
STD/EMUL/VENT		

### Tires / Wheels:

	FRONT	REAR
BRAND/TREAD		
COMPOUND		
INSERT		
WHEEL		

NOTES:

### Differential Oil:

FRONT	CENTER	REAR

### Electronics:

ESC: \_\_\_\_\_

Battery: \_\_\_\_\_

Motor: \_\_\_\_\_

Radio: \_\_\_\_\_

Servo: \_\_\_\_\_

### Drivetrain:

SPUR GEAR Metal  Composite

Traktion Drive  Elektri-Clutch  Pinion

PINION SIZE \_\_\_\_\_ (teeth)

Mechanical Brakes  Motor Brakes

### Chassis Braces:

Front  Middle  Rear

(front brace is always recommended)