

EB48 INSTRUCTIONS ADDENDUM

FOR BAGS A, B, C, D, M, & N

BAG A and BAG B -> STEP 2 (PAGE 3, 4)

The EB48 kit includes some small shims for adjusting the internal diff gear mesh (shown in step A-2 and B-2 - TKR5146). The instruction manual shows one shim behind each spider (small) gear. Due to manufacturing tolerances and variance between our pre-production parts and production parts, these small shims may cause the internal diff mesh to be very tight and crunchy. Simply remove the 4 shims and your diff should mesh normally.

The differential mesh may seem smoother when turning the outdrive on the non-gear side. This is normal. The differentials will **NEED TO BREAK IN** before you run the car for the first time. To do this, get your car ready to run, electronics installed, battery charged, ready to go...

Step 1 – Place the 2 left tires on the ground, ensure they do not move. Rev up to 1/8th throttle for 30 seconds allowing the 2 right tires to 'diff out'

Repeat Step 1 placing the 2 right tires on the ground.
Repeat Step 1 placing the 2 front tires on the ground.
Repeat Step 1 placing the 2 rear tires on the ground.

When done properly, breaking in the diffs will smooth out the diff action and ensure that they run freely during operation.



BAG C and BAG D -> STEP 1 (PAGE 5, 6)

Make sure that when installing the diff coupler (TKR5075), the M5x4mm (TKR1603) set screw is firmly seated on the flat spot of the diff pinion gear (TKR5110). See inset for clarification. Use thread lock on this screw and tighten down firmly.

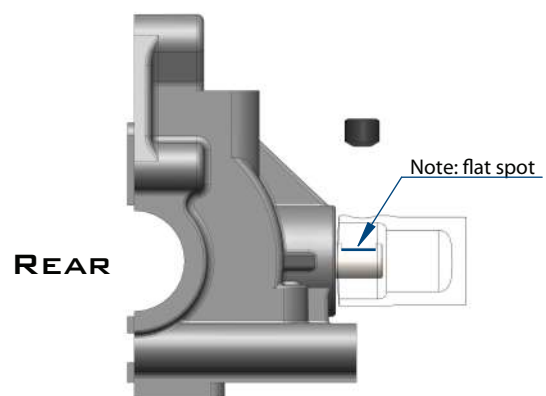
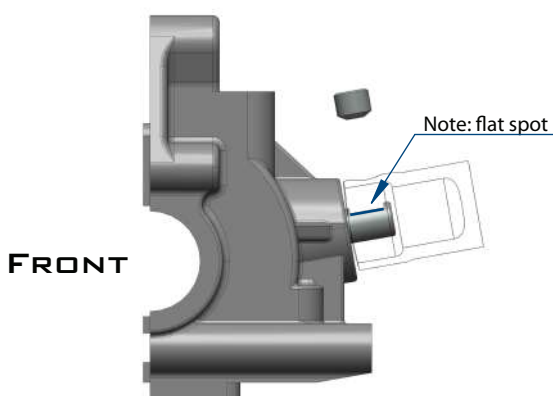

BAG M and BAG N -> STEP 1 (PAGE 20, 21)

Your EB48 kit included shock oil. Fill the front shocks with the #450 oil. Fill the rear shocks with the #350 oil. These oil weights roughly equate to 35 and 30wt respectively.

During assembly of the shocks it is important to fully tighten down the shock cap (TKR6003) and the cartridge cap (TKR6015). If they are loose, oil may leak. It should be tighter than hand tightening. Use an adjustable wrench to be sure they are on tight.

The oils supplied are a baseline setting and may not suit your track conditions or driving style. Experiment and have fun.