

Tekno RC Adjustable Wing Mount for T-Maxx

Thank you for your purchase and support. You'll find this wing mount to be easy to install and extremely durable. Please read and follow the instructions carefully to ensure proper installation and long product life. Thanks again!

STEP 01 - Remove rear shock tower. You should be able to easily reach and unscrew the 4 screws securing the rear shock tower. Next, remove the shocks from the tower (don't remove from a-arms). You should also remove the body mount posts for easier assembly. (Shock mount and wing shown for illustrative purposes only and are not included)

Look at Fig. 01 (below) and decide which Height / Angle mounting hole combination you are going to run. We recommend starting with the B-2 combination and adjusting from there.

STEP 02 - ***USE THREAD LOCKING COMPOUND ON THE M3x16mm BUTTON HEAD SCREWS AND ALUMINUM BRACES***

Starting with the two top aluminum braces and the nylon washers, **loosely** assemble the wing mount as shown in Fig. 2. When everything is in place, tighten up the 6 M3 x 16mm screws (remember the thread locking compound). Set the wing mount assembly aside for now.

STEP 03 - Next we will secure the wing mount assembly to the shock tower as shown in Fig. 3.

Start by inserting the 4 long screws (M3 x 30mm) into the X-brace, followed by the 8mm spacers.

Carefully position the shock tower and shock tower brace onto the X-brace assembly. Hold the loose assembly in one hand and place the wing mount assembly over the 4 protruding screws.

Fig. 3a shows a side view of the assembly. Note that the top two 8mm spacers should be sitting on top of the shock tower.

Insert the lower screws (M3 x 20mm) into the shock tower brace through the shock tower to properly align the wing mount with the shock tower.

Place the supplied M3 locknuts into the cutouts on the wing mount brackets and secure the wing mount assembly to the shock tower one screw at a time. You may need to wedge a small flat screw driver into the locknut cutouts to prevent the locknuts from spinning while tightening them down.

STEP 04 - Mount the wing of your choice (Fig. 04 on reverse side). Use the included drill template (below right) to help with drilling holes in your wing. Mugen wings already have holes drilled the proper distance apart. You may need to widen the holes a bit for a perfect fit. Other wings may also fit directly if they share the same dimensions as the Mugen wing.

If you lose or misplace the template, the wing mount posts are

40mm apart (center to center) and are 8mm in diameter. Secure the wing using the supplied M4x16mm button head screws, large stainless steel washers, and M4 locknuts.

STEP 05 - Reattach the shocks to the shock tower. Next, secure

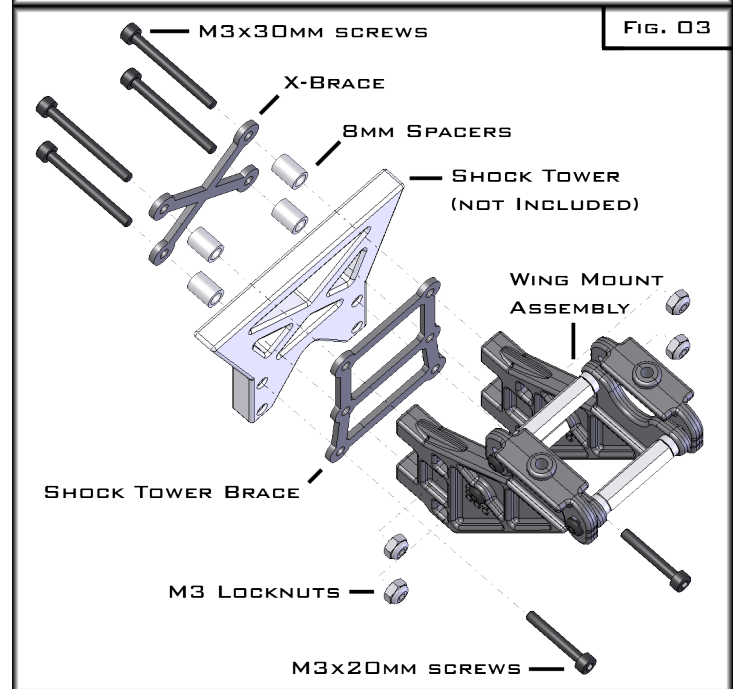
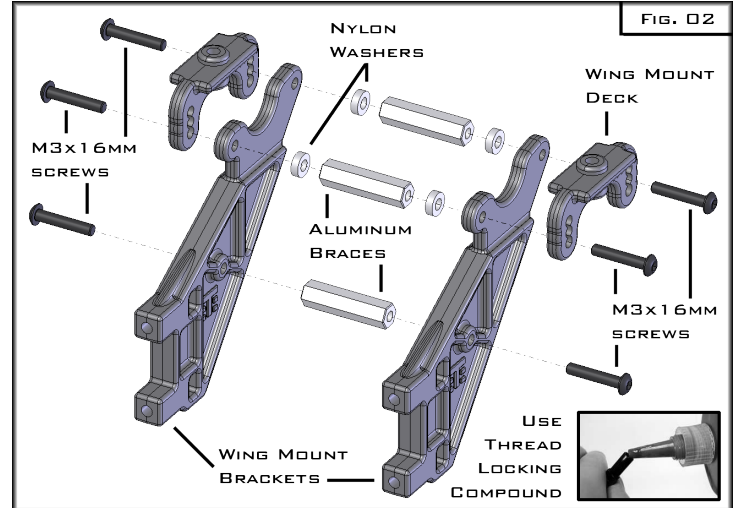
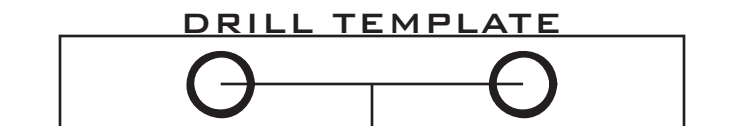
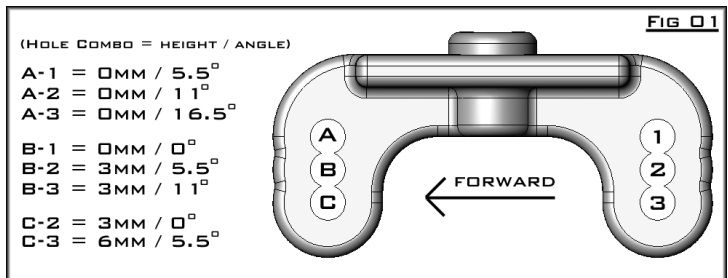
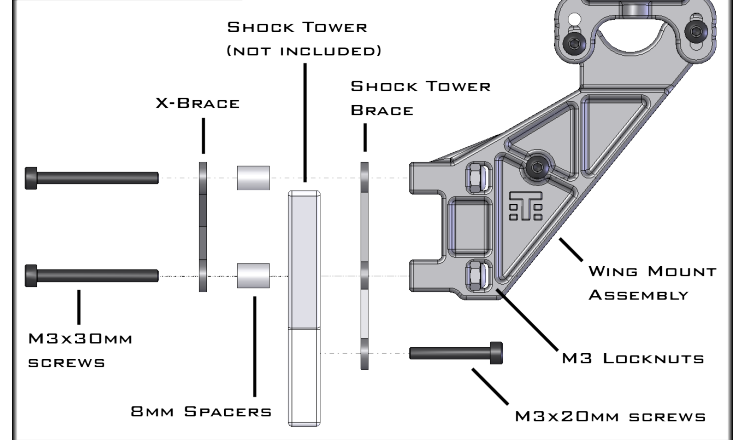
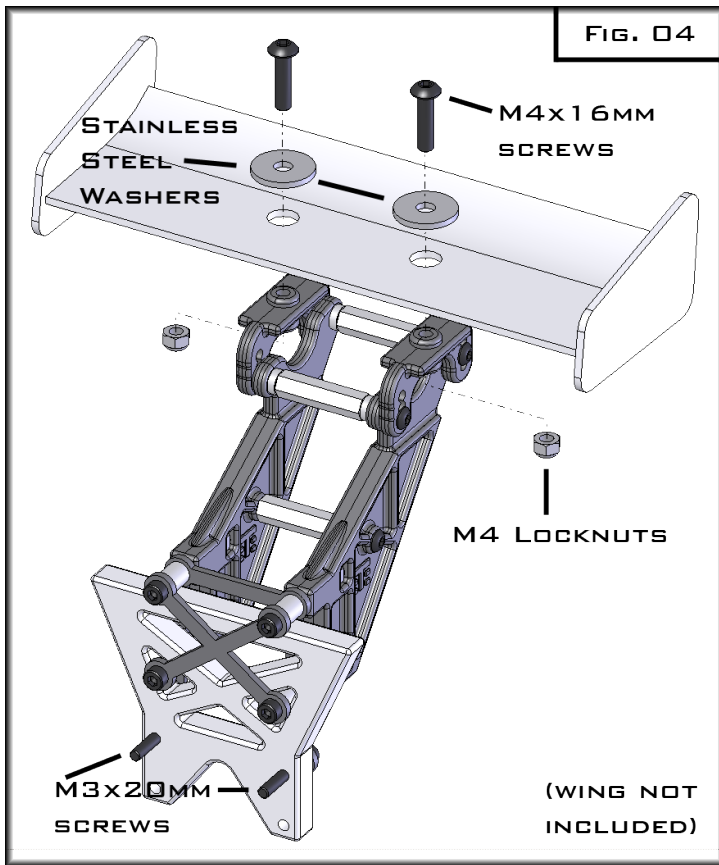

FIG. 03A (SIDE VIEW)





the shock tower using the supplied M3x20mm screws on the top holes. The longer screws are needed to compensate for the shock tower brace thickness. Use the stock screws on the bottom shock mount holes.

Reinstall the body mount post. The lower you set it, the higher the wing will appear to sit.

Done! – Enjoy your new wing mount. **Note:** You will most likely need to cut away some of your vehicle's body to allow it to clear the mounts. We tried to avoid this, but any sort of mount will more than likely require body modifications. Thank you for choosing Tekno RC!

Check www.teknorc.com for great deals on all of your hobby needs including kits, hop-ups, spare parts, radios, servos, tools, accessories, and more.

Do you have a product that you think should be produced? Drop us an email at teknorc@teknorc.com. We're always listening to our customers' needs.

If you experience any issues or have any questions, please do not hesitate to contact us (teknorc@teknorc.com | 877-857-2872). We'll do everything we can to make sure you are a satisfied customer.