



BUILDING
INSTRUCTIONS



INTRODUCTION



Thank you for purchasing the Tekno RC EB48.3 1/8th Scale Electric Competition Buggy Kit. The EB48.3 represents a continued evolution in the 1/8th scale electric class. Since the original EB48 was released in 2012, we have continued to focus on refining and improving the vehicle to provide superior performance and value to our customers. We are always working on new projects, so please check our website (www.teknorc.com) regularly for the latest news, parts, and kits. Thanks again.

Additional equipment and parts needed:

2/3 channel radio transmitter and receiver
1/8th scale ESC and motor
High torque steering servo (240 oz/in torque minimum)
4-6s LiPo battery
1/8th scale buggy tires, wheels & CA glue
Paint for Body
MOD1 Pinion (TKR4171->TKR4190)

Tools needed:

Hex drivers 1.5mm (TKR1104), 2.0mm (TKR1105), 2.5mm (TKR1106)
Nut drivers 5.0mm (TKR1107), 5.5mm (TKR1108), 7.0mm (TKR1109)
17mm Wheel Wrench (TKR1116)
Hobby knife
Needle-nose pliers
Adjustable (Crescent) wrench (for shock assembly)
4mm turnbuckle wrench (TKR1103)
4mm arm reamer
Lexan Body Scissors

Disclaimer: Tekno RC is not responsible or liable for any property or personal damage, loss, or injury incurred as a result of using this product. This kit is meant for use by persons 14 years of age or older and in the strict confines of a legally permitted RC track or facility.

Warnings: Always double-check that your radio gear is working properly before operating vehicle. Never operate the vehicle indoors (unless the RC track is an indoor facility). Use caution while operating vehicle so as not to collide with people who may be turn marshalling or who might otherwise not be aware that a fast moving RC vehicle is in the vicinity.

Warranty: We warrant that the parts included in this kit are free from defects. If you find a defective part in your kit, please contact us @ info@teknorc.com and we will help you to resolve the issue. We do not warranty parts that may be broken during operation of the vehicle or otherwise. Refer to the end of this instruction manual for a listing of spare/replacement and option parts. All spare parts and other info are available on our website (www.teknorc.com) and through our network of domestic and international dealers and distributors.

BAG A

CENTER DIFFERENTIAL

(OVERVIEW)

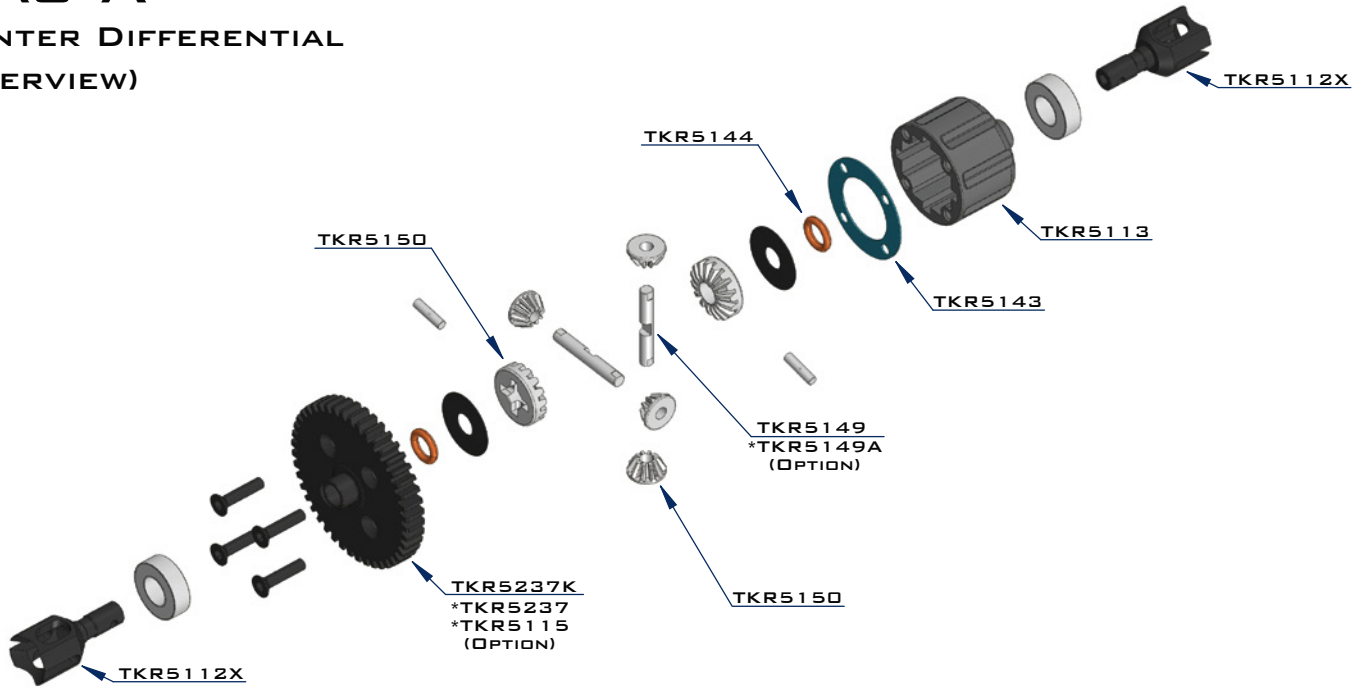

STEP A-1

Apply grease to the groove where the o-ring is placed as well as the o-ring itself

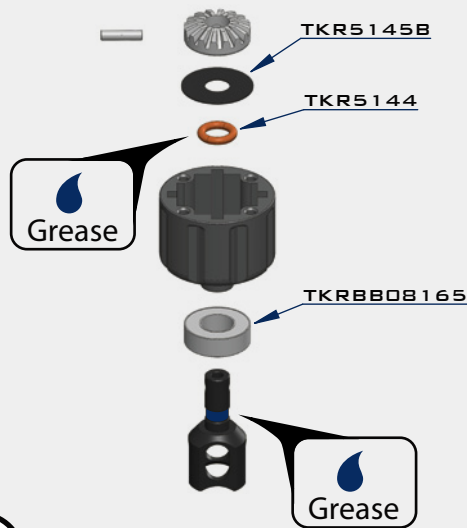

Apply grease to the groove in the outdrive

STEP A-2

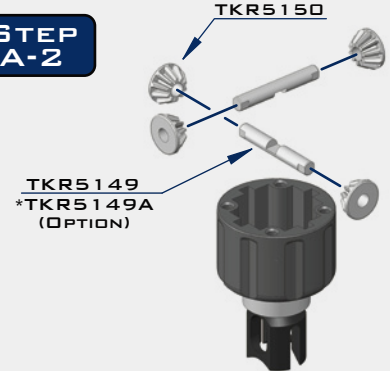

STEP A-4

Apply grease to the groove in the outdrive

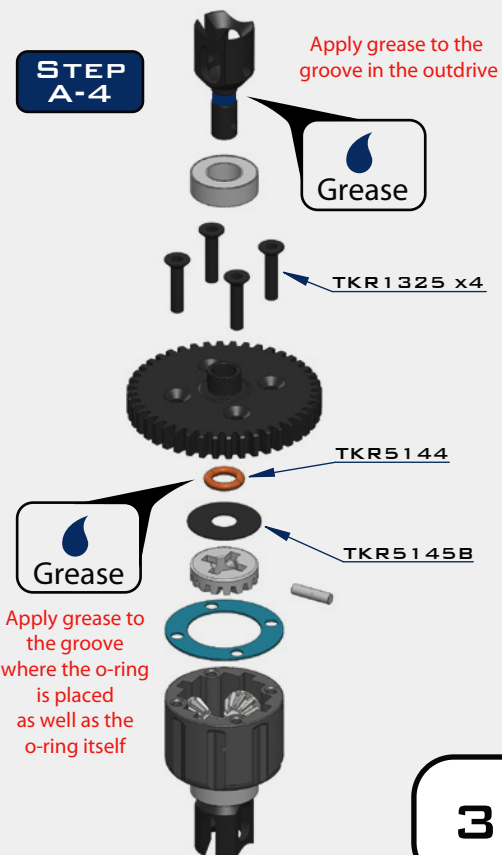

Apply grease to the groove where the o-ring is placed as well as the o-ring itself

STEP A-3

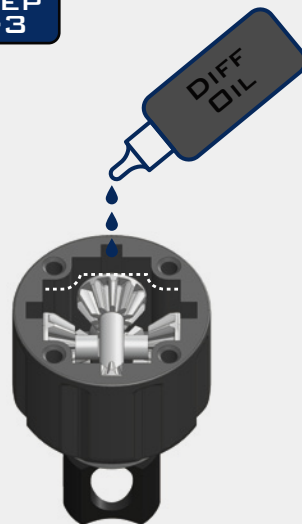

Fill with 5000 wt oil to 1mm below full
DO NOT OVER FILL

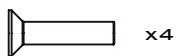

TKR1325
M3X14MM FLAT HEAD SCREW



TKR5144
DIFFERENTIAL O-RINGS

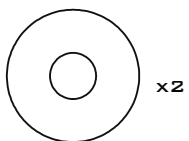

TKR5145B
DIFFERENTIAL SHIMS (6X17MM)



TKRBB08165
BALL BEARING(8X16X5MM)

BAG B

FRONT AND REAR DIFFERENTIAL (OVERVIEW)

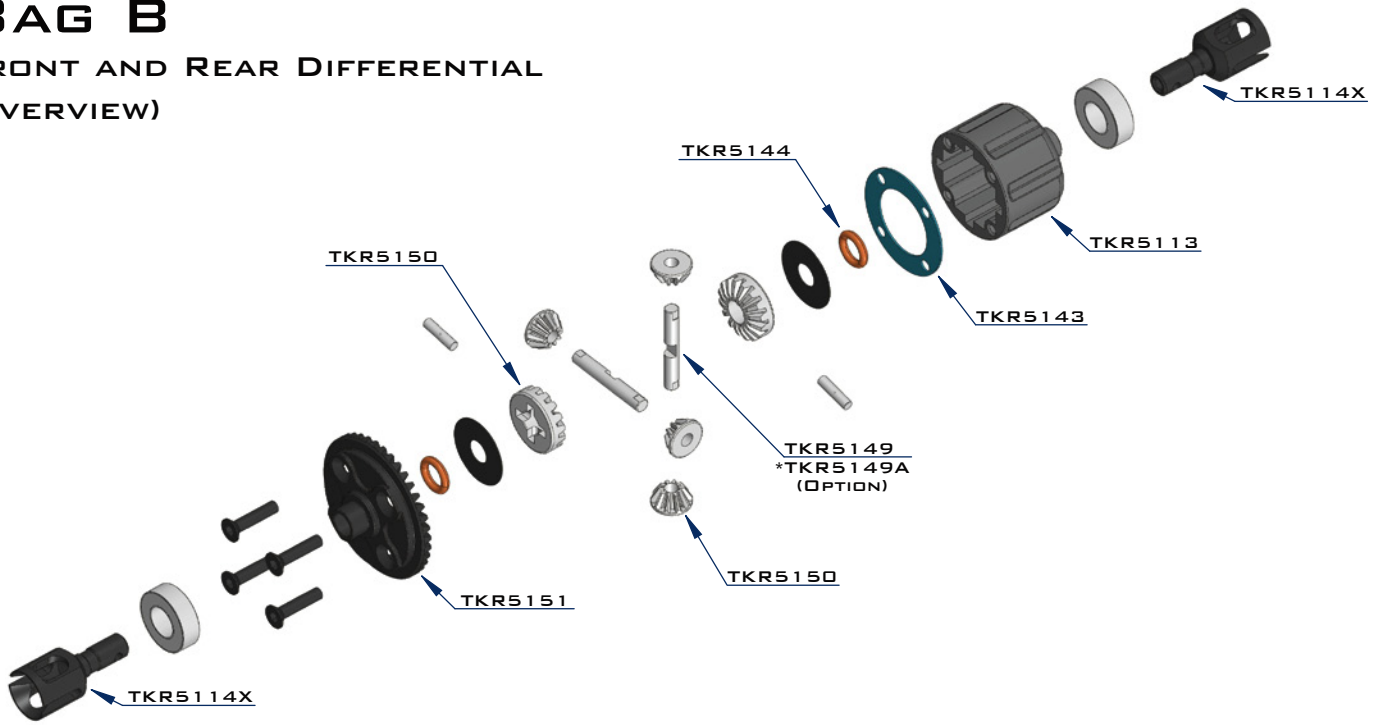

STEP B-1

Repeat for rear diff

Apply grease to the groove where the o-ring is placed as well as the o-ring itself

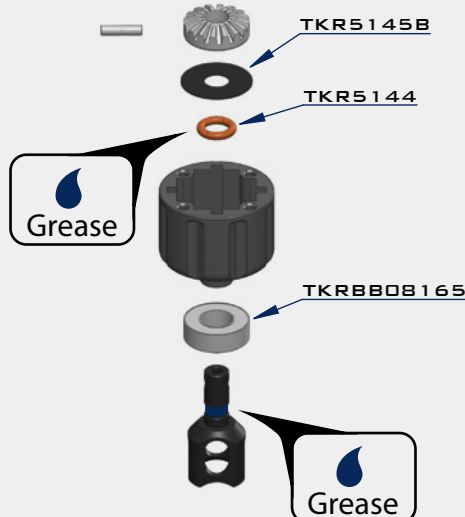

STEP B-2

Repeat for rear diff

TKR5149
*TKR5149A (OPTION)

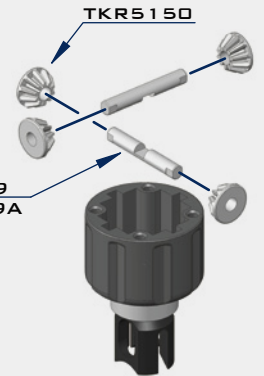

STEP B-4

Repeat for rear diff

Apply grease to the groove in the outdrive

Apply grease to the groove where the o-ring is placed as well as the o-ring itself

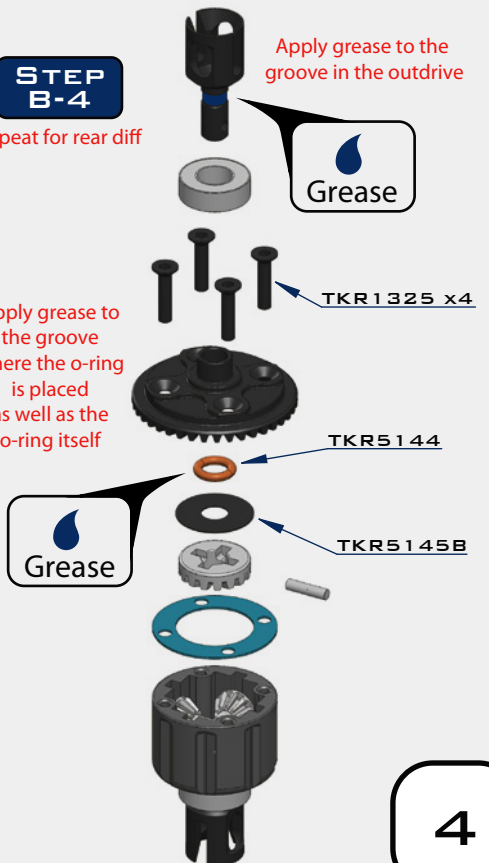

STEP B-3

Repeat for rear diff

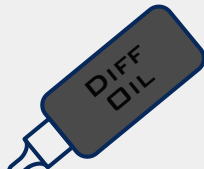

Fill FRONT with 5000 wt oil
Fill REAR with 5000 wt oil
to 1mm below full
DO NOT OVER FILL



TKR1325
M3X14MM FLAT HEAD SCREW



TKR5144
DIFFERENTIAL O-RINGS

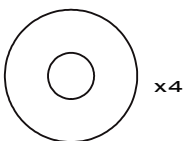

TKR5145B
DIFFERENTIAL SHIMS (6X17MM)



TKRBB08165
BALL BEARING(8X16X5MM)

BAG C

FRONT GEARBOX (OVERVIEW)

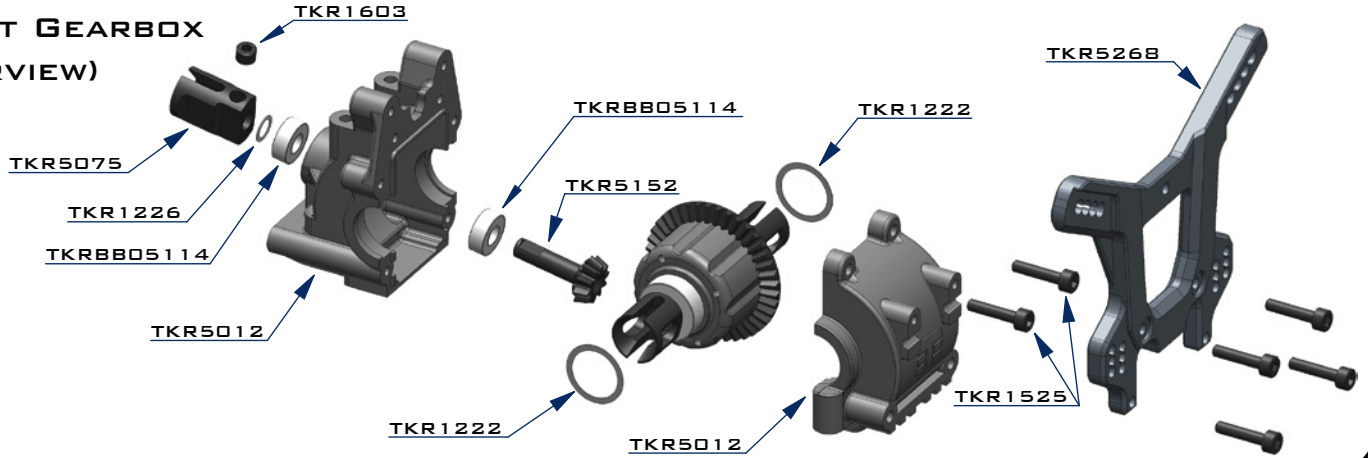

STEP C-1

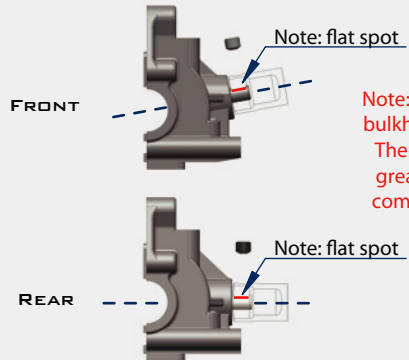
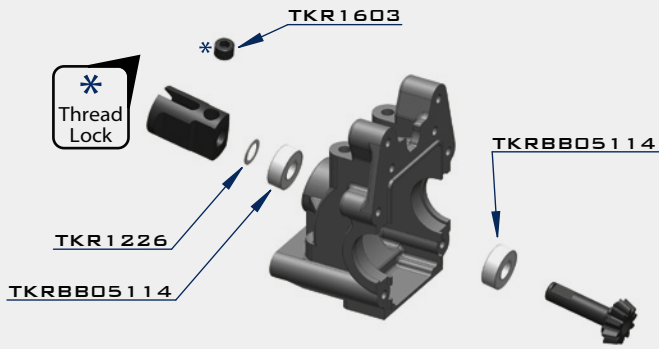

Note: The front and rear bulkheads are different. The front has a much greater output angle compared to the rear.

Note: TKR1222 and TKR1226 Shims - The gear mesh should be tight without any binding. TKR1226 should always be installed. Then test fitment of the diff with both TKR1222 shims on the gear-side of the diff. If the diff turns freely without binding, continue to next step. If the diff binds and does not turn freely (it will make a grinding or crunching sound when spun), remove one TKR1222 shim from the gear side and install it onto the other side of the diff. Reassemble and test the mesh again. If it is still binding, remove the second TKR1222 shim from the gear side and install it onto the other side of the diff. When you are satisfied that you have the best gear mesh possible continue to the next step. You may end up using only one shim on the gear side.

STEP C-2



-  x2
TKR1222
13x16x0.1MM DIFF SHIM
-  x1
TKR1226
5x7x0.2MM SHIM
-  x6
TKR1525
M3x14MM CAP HEAD SCREW
-  x1
TKR1603
M5x4MM SET SCREW
-  x2
TKRBB05114
BALL BEARING (5x11x4)

STEP C-3

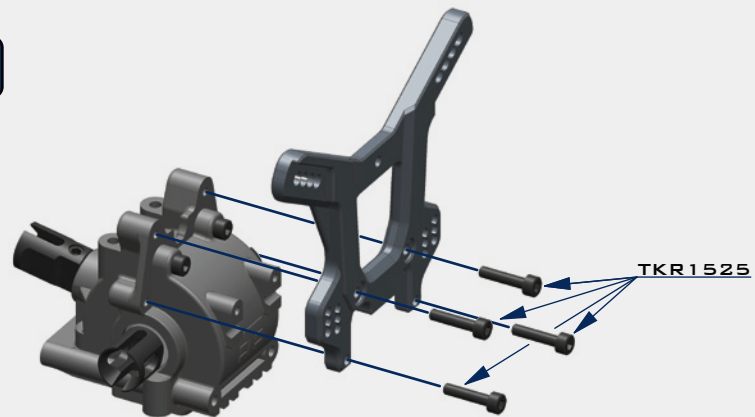

BAG D

REAR GEARBOX (OVERVIEW)

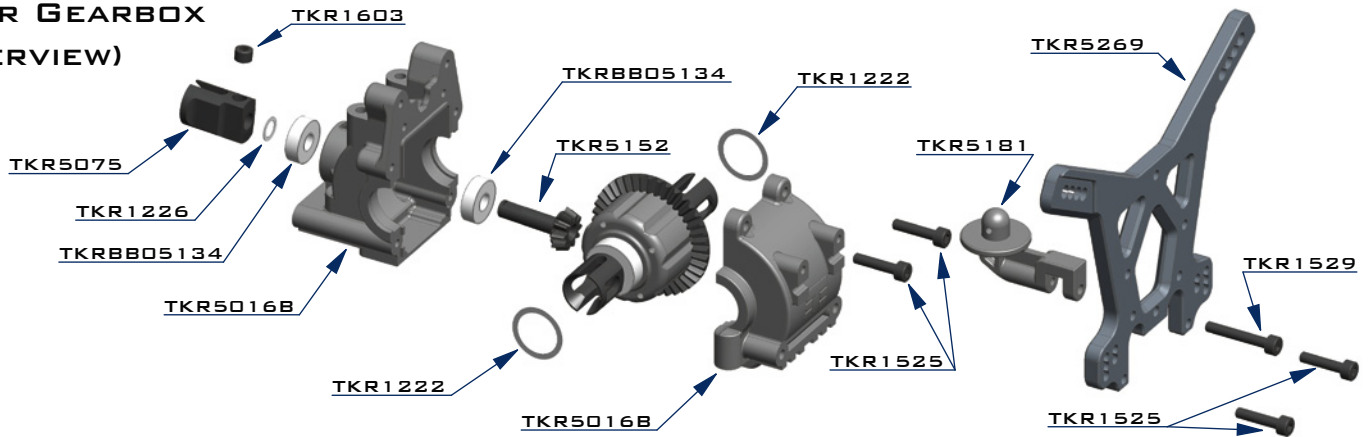

STEP D-1

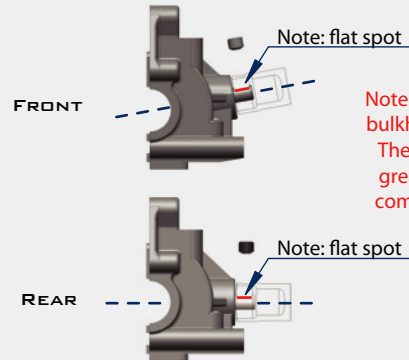
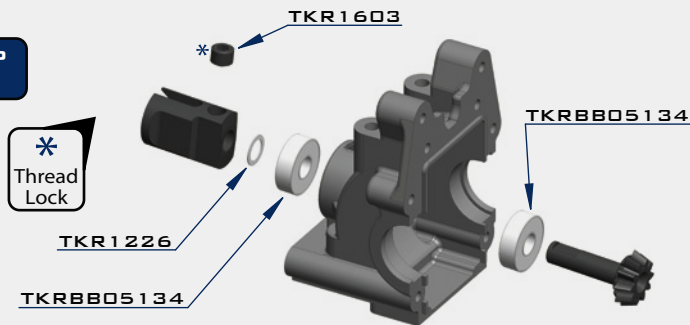

Note: The front and rear bulkheads are different. The front has a much greater output angle compared to the rear.

Note: TKR1222 and TKR1226 Shims - The gear mesh should be tight without any binding. TKR1226 should always be installed. Then test fitment of the diff with both TKR1222 shims on the gear-side of the diff. If the diff turns freely without binding, continue to next step. If the diff binds and does not turn freely (it will make a grinding or crunching sound when spun), remove one TKR1222 shim from the gear side and install it onto the other side of the diff. Reassemble and test the mesh again. If it is still binding, remove the second TKR1222 shim from the gear side and install it onto the other side of the diff. When you are satisfied that you have the best gear mesh possible continue to the next step. You may end up using only one shim on the gear side.

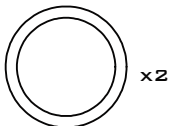

TKR1222
13X16X0.1MM DIFF SHIM



TKR1226
5X7X0.2MM SHIM

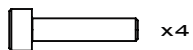

TKR1525
M3X14MM CAP HEAD SCREW

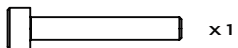

TKR1529
M3X20MM CAP HEAD SCREW



TKR1603
M5X4MM SET SCREW



TKRBB05134
BALL BEARING (5X13X4)

STEP D-2

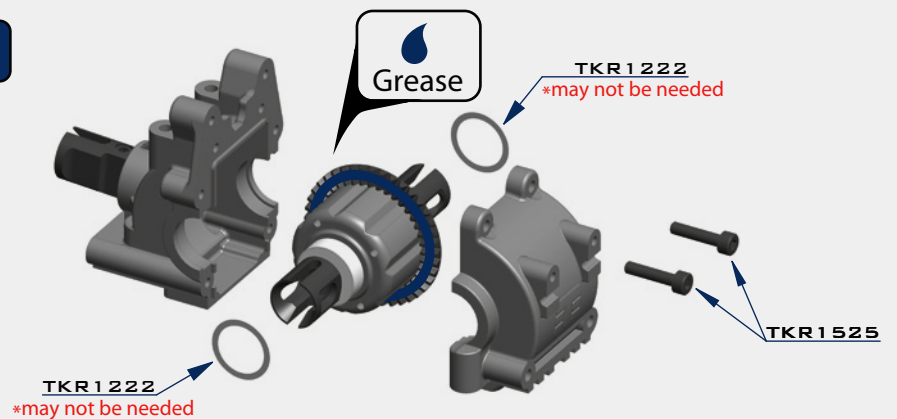

STEP D-3

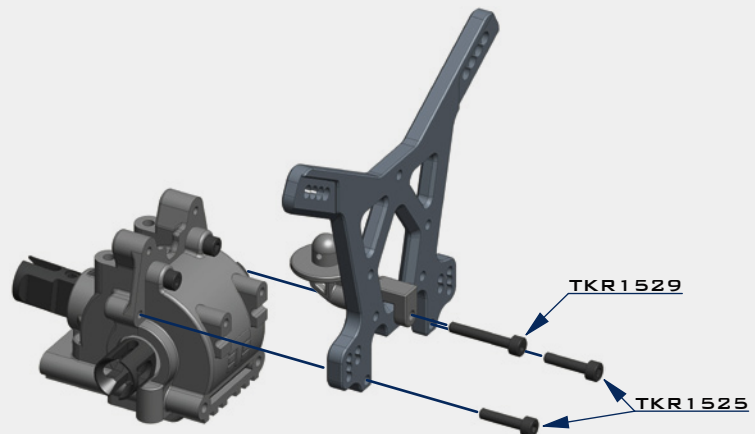

BAG E

LOW PROFILE WING MOUNT

SETTINGS

POSITION SETTINGS

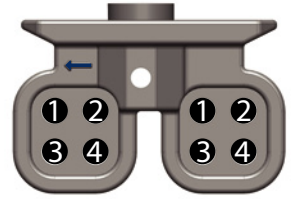

- 1 - REARWARD LOW
- 2 - FOREWARD LOW
- 3 - REARWARD HIGH
- 4 - FOREWARD HIGH

Note: Stock position setting is # 4, Rearward High

DOWNFORCE SETTINGS

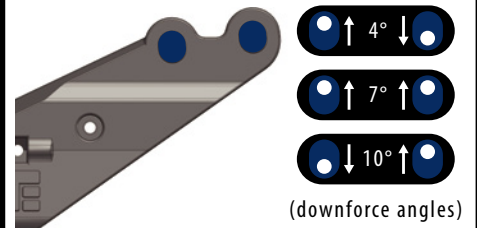

(downforce angles)

Note: Stock downforce setting is 4°

STEP E-1

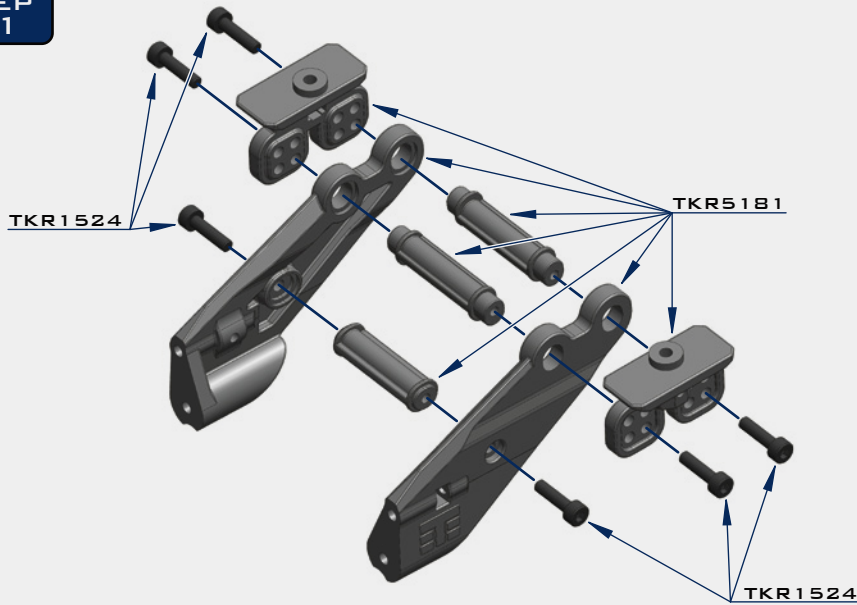

STEP E-2

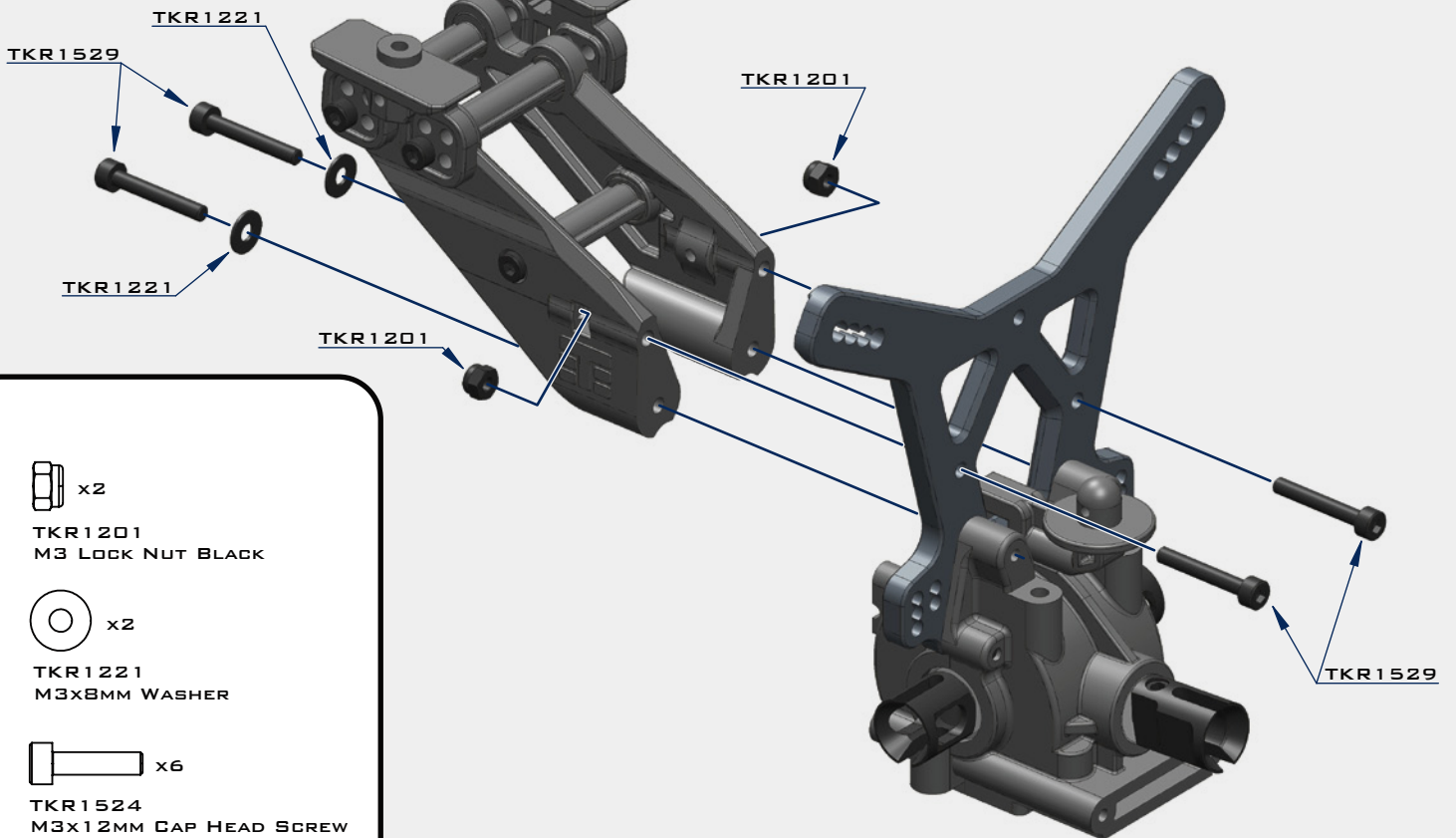

 x2
TKR1201
M3 LOCK NUT BLACK

 x2
TKR1221
M3x8MM WASHER

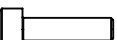
 x6
TKR1524
M3x12MM CAP HEAD SCREW

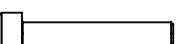
 x4
TKR1529
M3x20MM CAP HEAD SCREW

BAG F

REAR END

STEP F-1

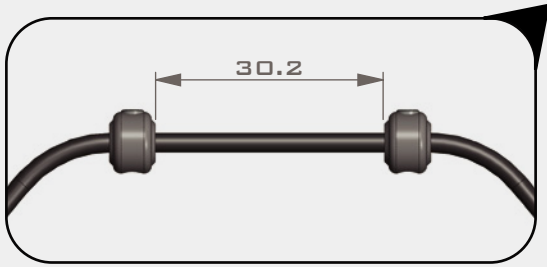

- TKR5491 - 2.4MM
- *TKR5490 - 2.3MM
- *TKR5492 - 2.5MM
- *TKR5493 - 2.6MM
- *TKR5494 - 2.8MM
- *TKR5495 - 3.0MM (OPTION)

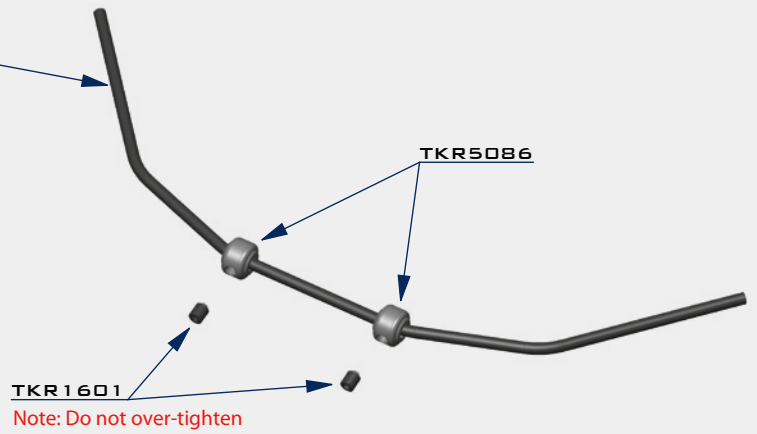

STEP F-2

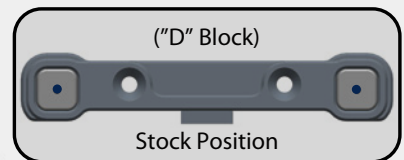
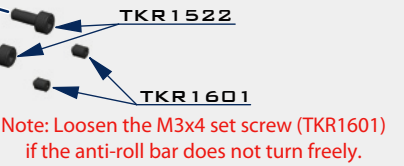
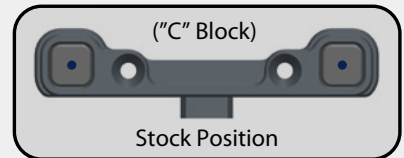
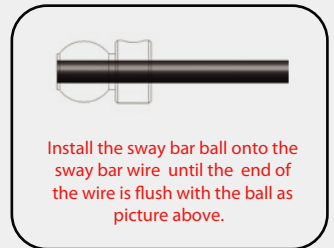
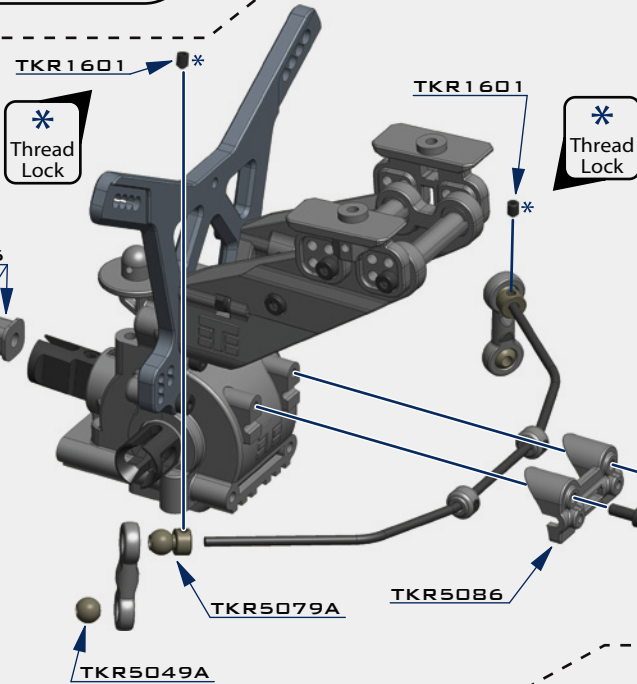
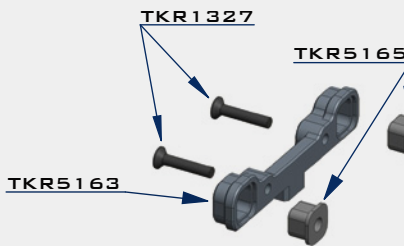

Note: With these stock center dot settings, Anti-Squat = 2° / Rear Toe = 3°

STEP F-3

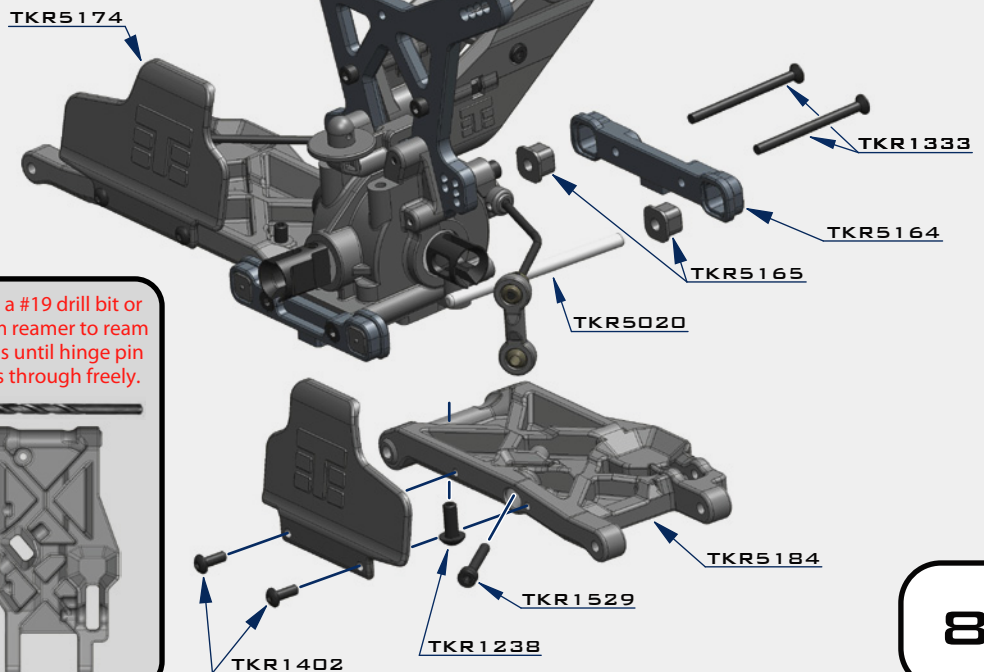

Use a #19 drill bit or 4mm reamer to ream arms until hinge pin falls through freely.

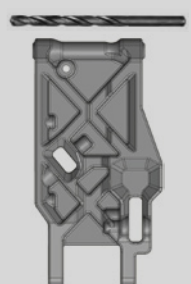

- x2
- TKR1238
- M4x10MM DROOP SCREW
- x2
- TKR1327
- M3x16MM FLAT HEAD SCREW
- x2
- TKR1333
- M3x40MM FLAT HEAD SCREW
- x4
- TKR1402
- M3x8MM BUTTON HEAD SCREW
- x2
- TKR1522
- M3x8MM CAP HEAD SCREW
- x2
- TKR1529
- M3x20MM CAP HEAD SCREW
- x6
- TKR1601
- M3x4MM SET SCREW
- x2
- TKR5049A
- PIVOT BALL SWAY BAR
- x2
- TKR5079A
- STABILIZER BALL

BAG G

REAR HUB/CVA ASSEMBLY



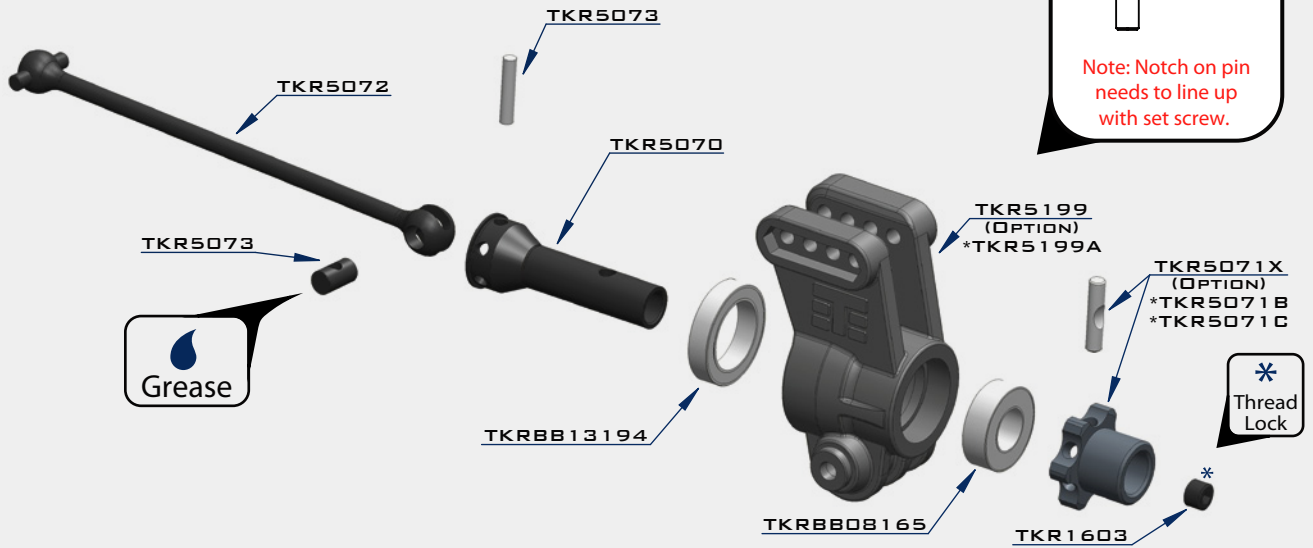

Note: Notch on pin needs to line up with set screw.

STEP G-1

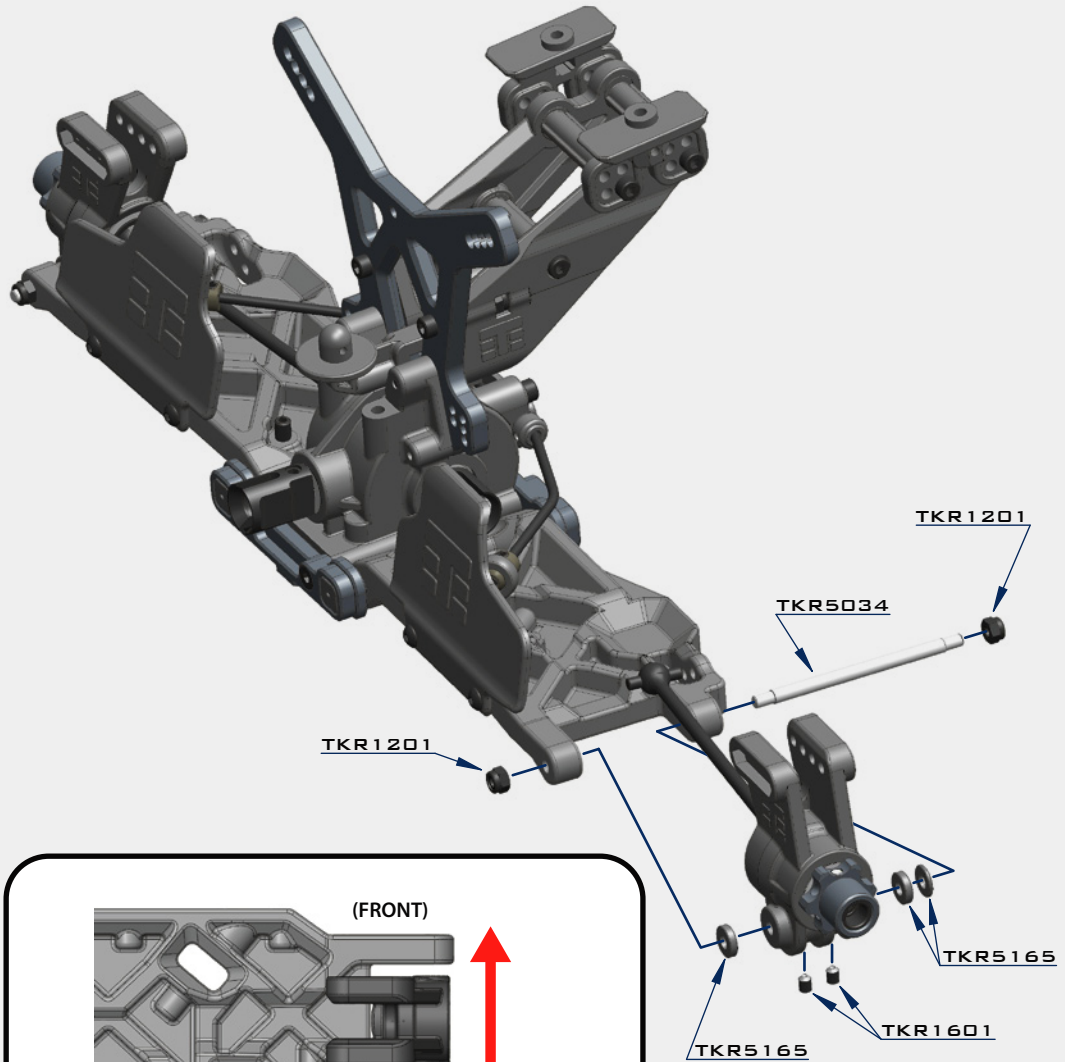

STEP G-2

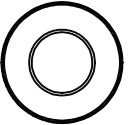
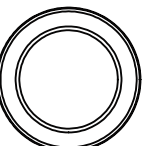

-  x4
TKR1201
M3 LOCKNUT BLACK
-  x4
TKR1601
M3X4MM SET SCREW
-  x2
TKR1603
M5X4MM SET SCREW
-  x2
TKR5071X
M3X16.8MM PIN
-  x2
TKR5073
CV JOINT PIN
-  x2
TKRBB08165
BALL BEARING (8X16X5)
-  x2
TKRBB13194
BALL BEARING (13X19X4)

(FRONT)  (REAR)

Changes to the wheelbase have a dramatic effect on handling, since it shifts the distribution of weight over the rear wheels. This adjusts traction. By shortening the wheelbase at the rear, you are placing more weight over the rear wheels.

Changes to the wheelbase also change the amount of sweep the rear driveshaft will have. More driveshaft sweep creates an effect similar to anti-squat, where the rear end gets pushed upwards on throttle. This helps reduce chassis slap when landing jumps on throttle.

BAG G

REAR CAMBER LINKS

This side mounts on hub
Note: no flange

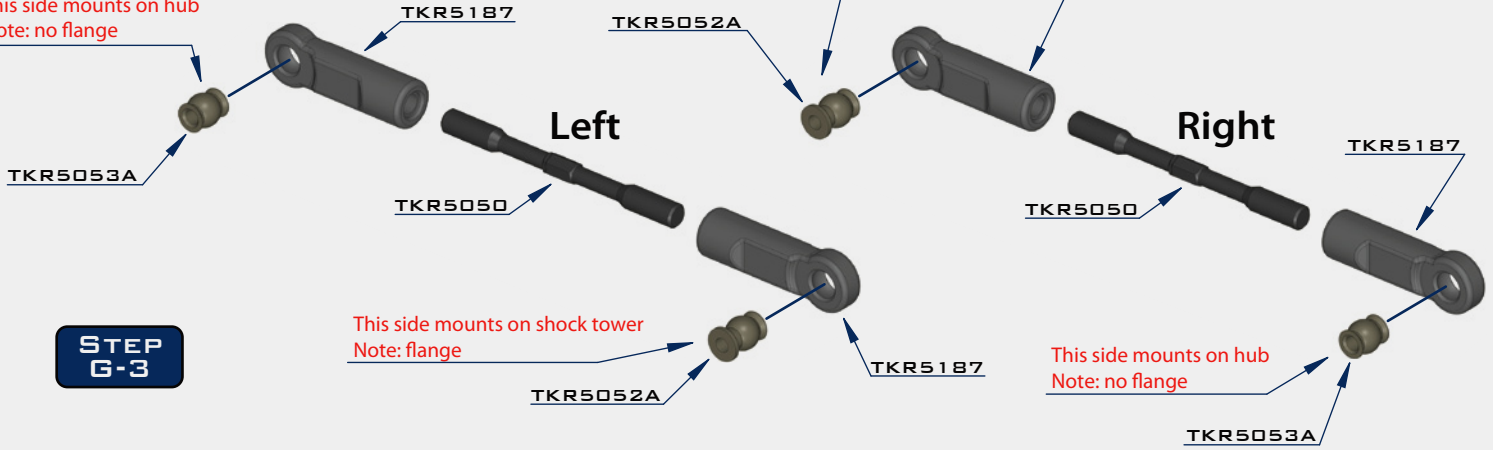

STEP G-3

STEP G-4

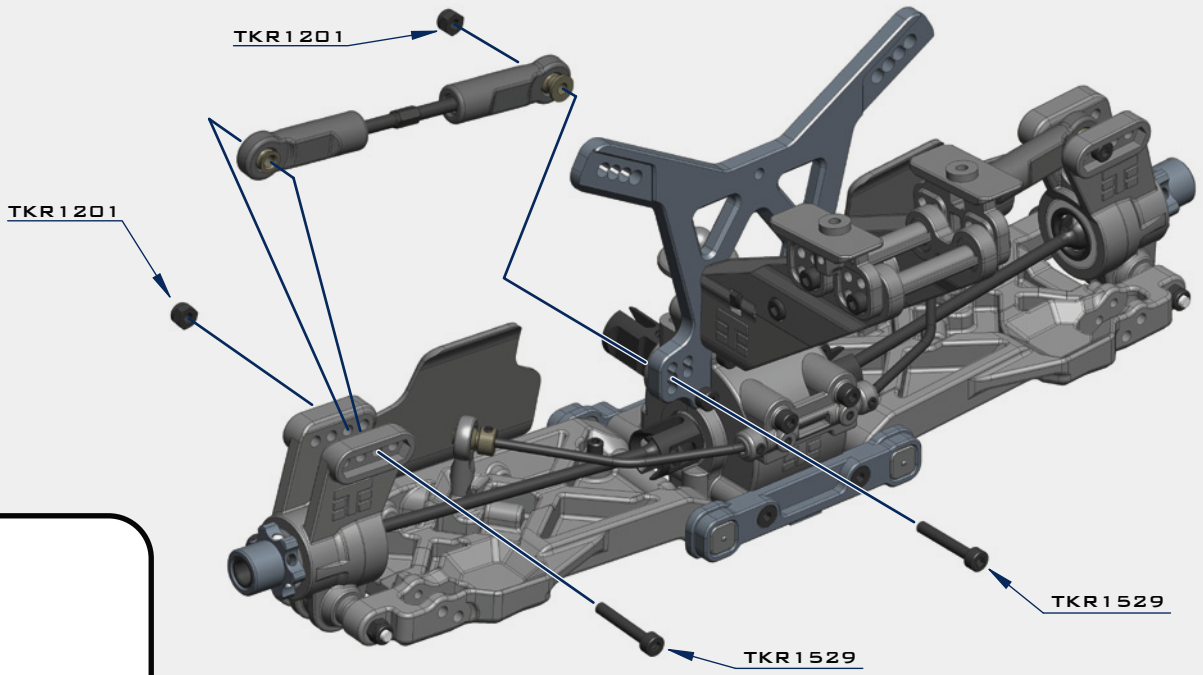
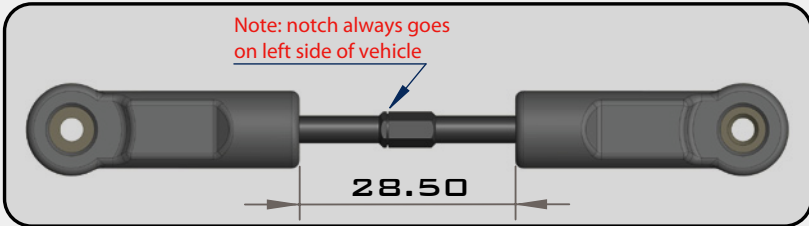

x4
TKR1201
M3 LOCKNUT BLACK

x4
TKR1529
M3X20MM CAP HEAD SCREW

x2
TKR5052A
PIVOT BALL M3X6.8MM

x2
TKR5053A
PIVOT BALL M3X6.8MM
NO FLANGE

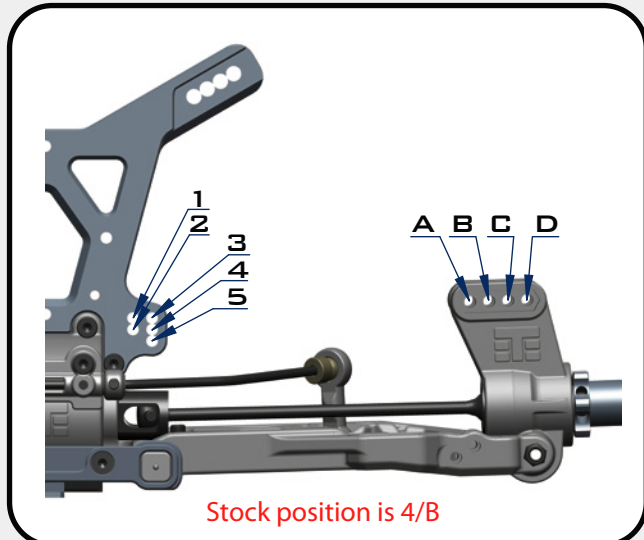

BAG H

FRONT END

STEP H-1

- TKR5082 - 2.4MM
- *TKR5080 - 2.2MM
- *TKR5081 - 2.3MM
- *TKR5083 - 2.5MM
- *TKR5084 - 2.6MM
- *TKR5085 - 2.8MM
- *TKR5087 - 3.0MM (OPTION)

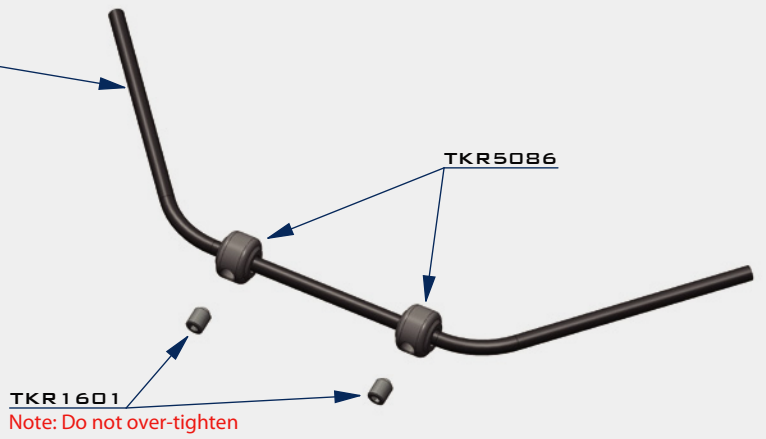
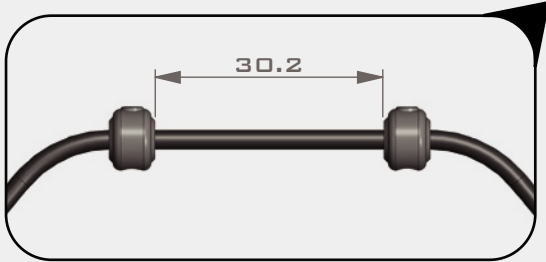

STEP H-2

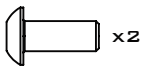
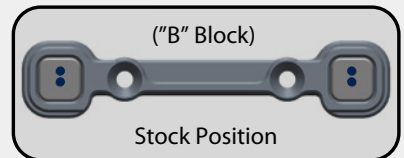
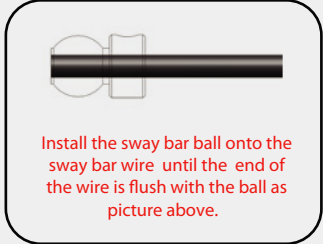
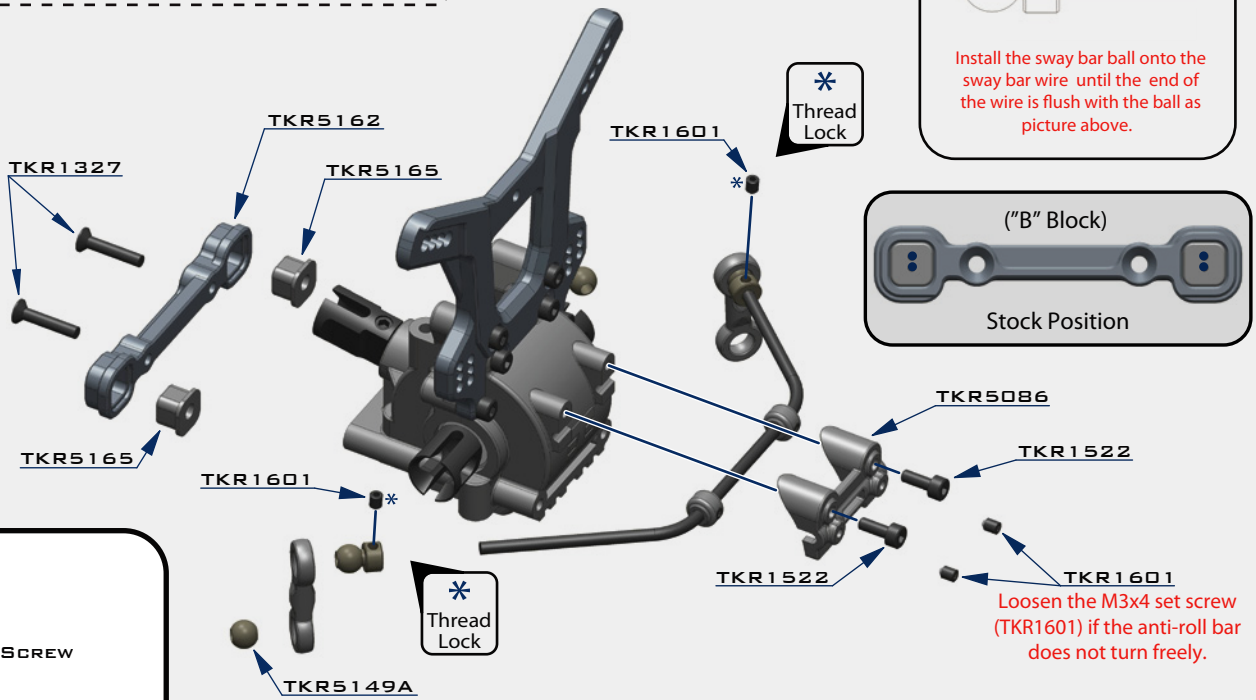

TKR1238
M4X10MM DROOP SCREW

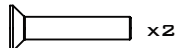

TKR1327
M3X16MM FLAT HEAD SCREW

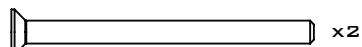

TKR1333
M3X40MM FLAT HEAD SCREW



TKR1522
M3X8MM CAP HEAD SCREW

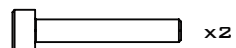

TKR1529
M3X20MM CAP HEAD SCREW



TKR1601
M3X4MM SET SCREW

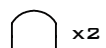

TKR5049A
PIVOT BALL SWAY BAR



TKR5079A
STABILIZER BALL

STEP H-3

Use a #19 drill bit or 4mm reamer to ream arms until hinge pin falls through freely.

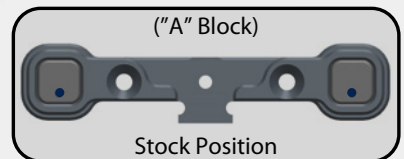
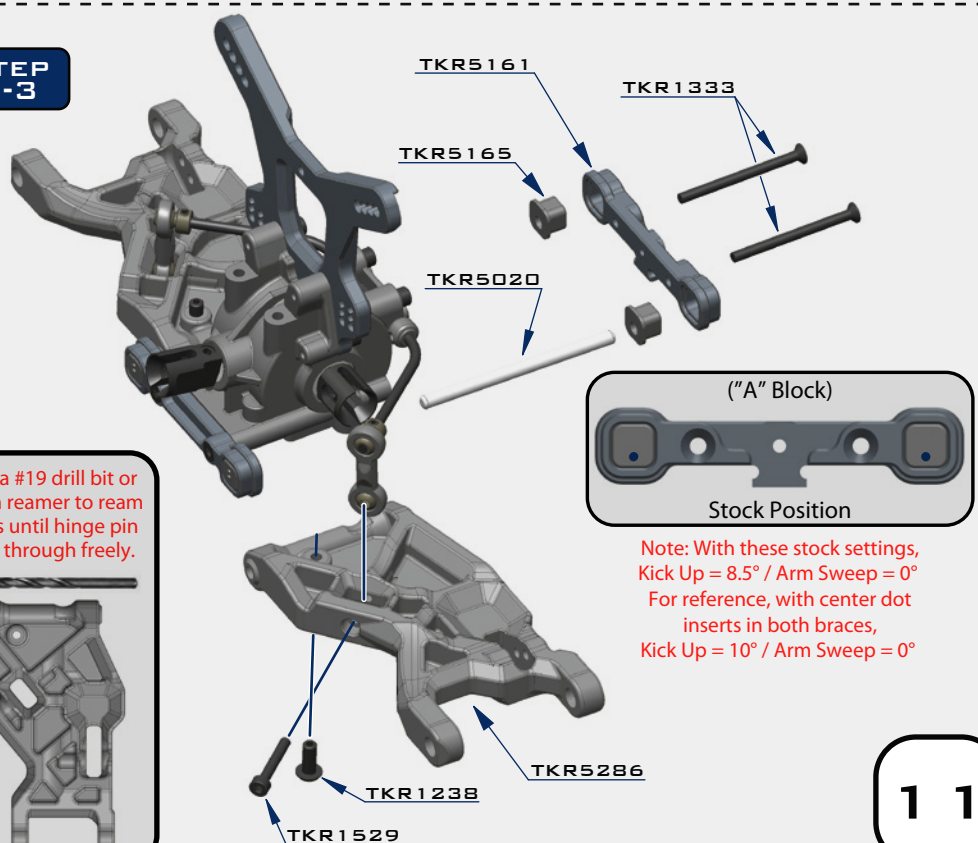
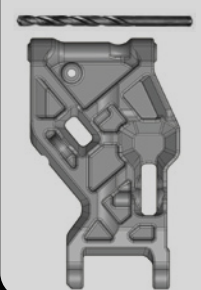

BAG I

FRONT SPINDLE / CVA ASSEMBLY

Note: notch on pin needs to line up with set screw.

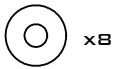
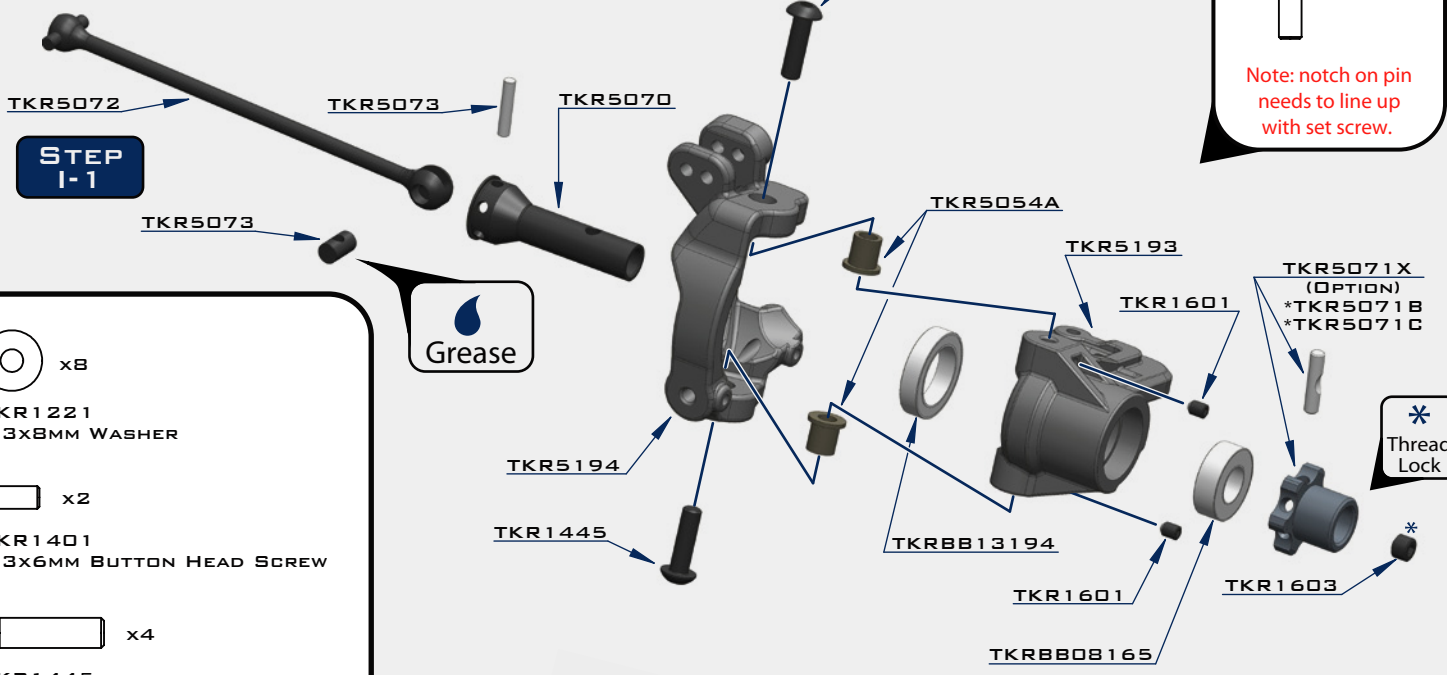

x8
TKR1221
M3x8MM WASHER



x2
TKR1401
M3x6MM BUTTON HEAD SCREW

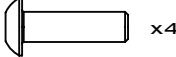

x4
TKR1445
M4x14MM BUTTON HEAD SCREW

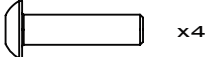

x4
TKR1447
M4x16MM BUTTON HEAD SCREW



x8
TKR1601
M3x4MM SET SCREW



x2
TKR1603
M5x4MM SET SCREW

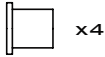

x4
TKR5054A
SPINDLE PIN SLEEVE

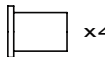

x4
TKR5055A
SUSPENSION PIN SLEEVE

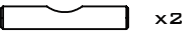

x2
TKR5071X
M3x16.8MM PIN

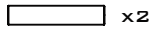

x2
TKR5073
CV JOINT PIN



x2
TKRBB08165
BALL BEARING (8x16x5)

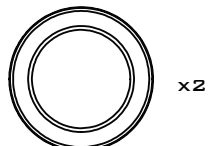

x2
TKRBB13194
BALL BEARING (13x19x4)

STEP 1-2

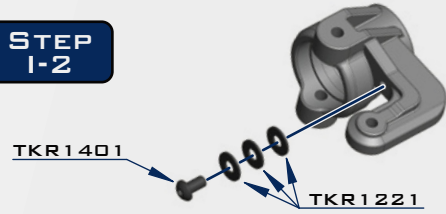

Note: The steering stops provide adjustable travel limiters that you can adjust to your driving style. For very tight tracks you may want to experiment with less limiting washers (more steering travel). However, with too much steering travel the rear end can lose traction more easily coming out of corners. After months of testing on different track surfaces, 3 washers is the best starting point.

STEP 1-3

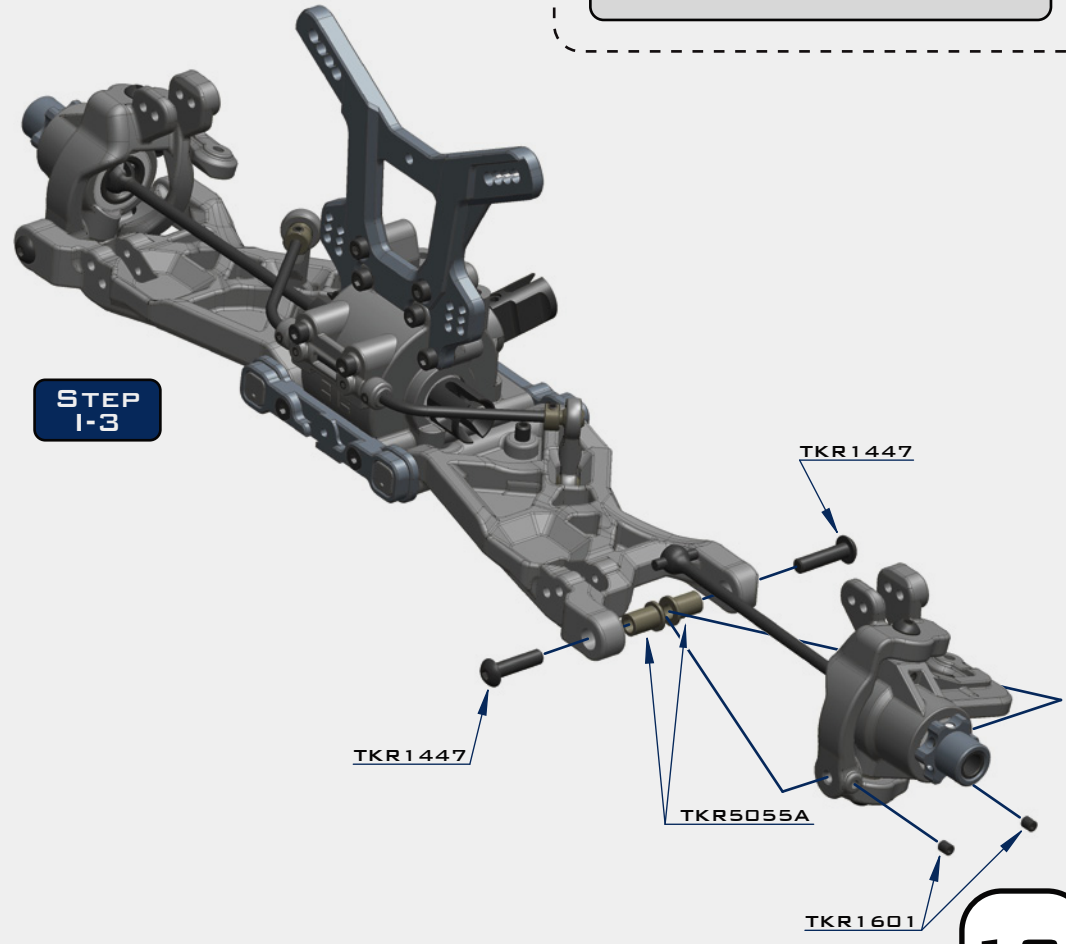

BAG I

FRONT CAMBER LINKS

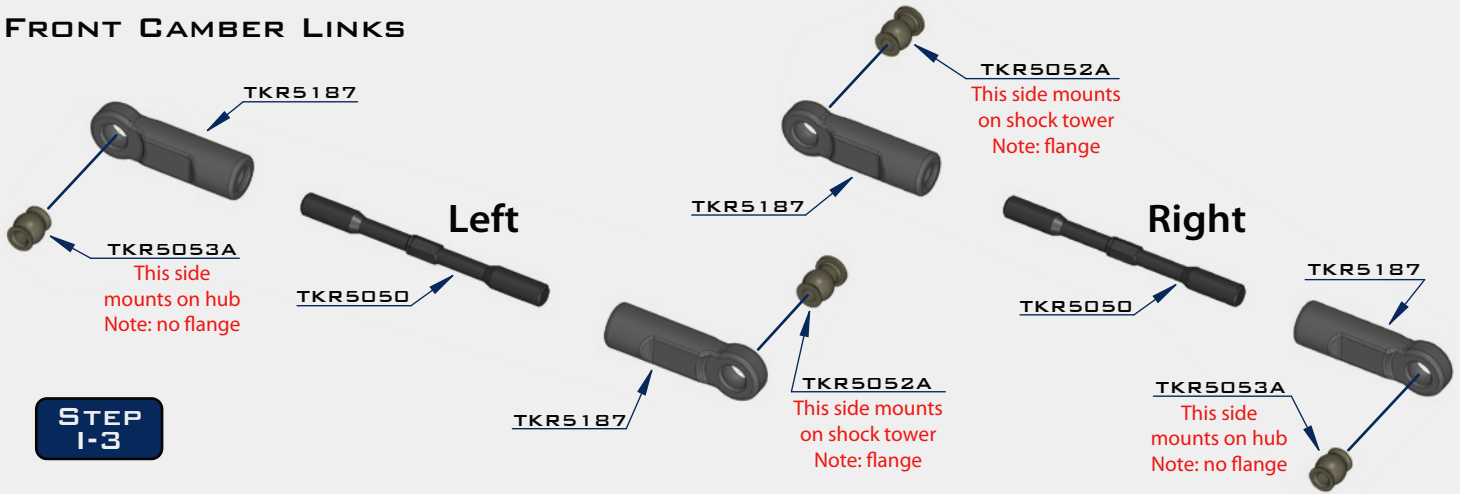

STEP 1-3

STEP 1-4

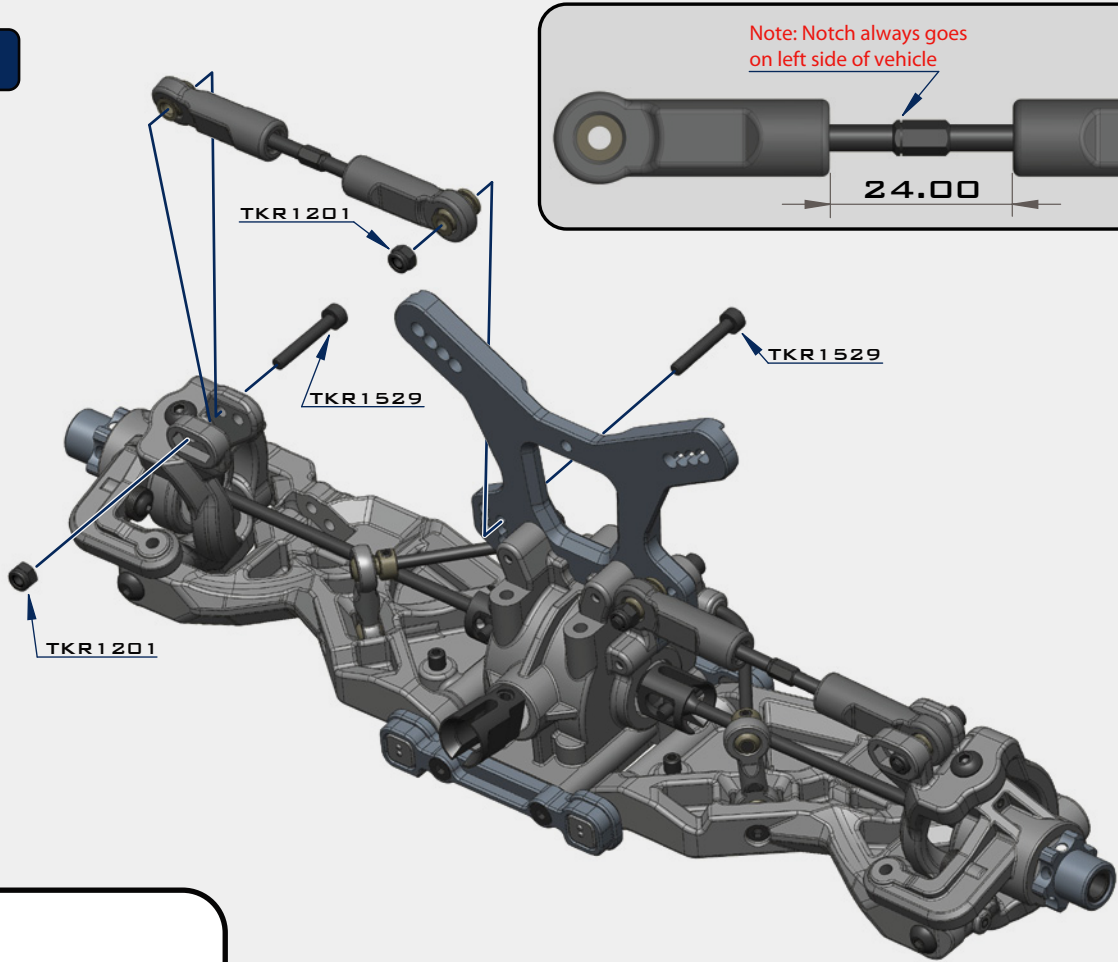

x4
TKR1201
M3 LOCK NUT BLACK

x4
TKR1529
M3X20MM CAP HEAD SCREW

x2
TKR5052A
PIVOT BALL M3X6.8MM

x2
TKR5053A
PIVOT BALL M3X6.8MM
NO FLANGE

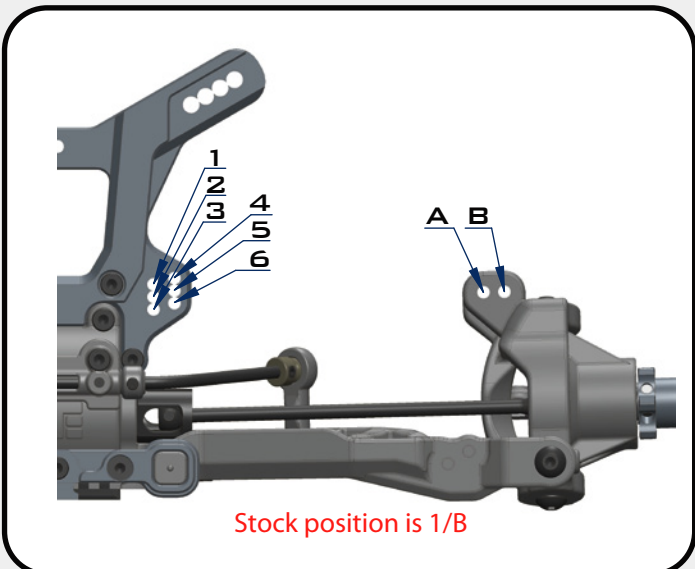

BAG J

STEERING ASSEMBLY (OVERVIEW)

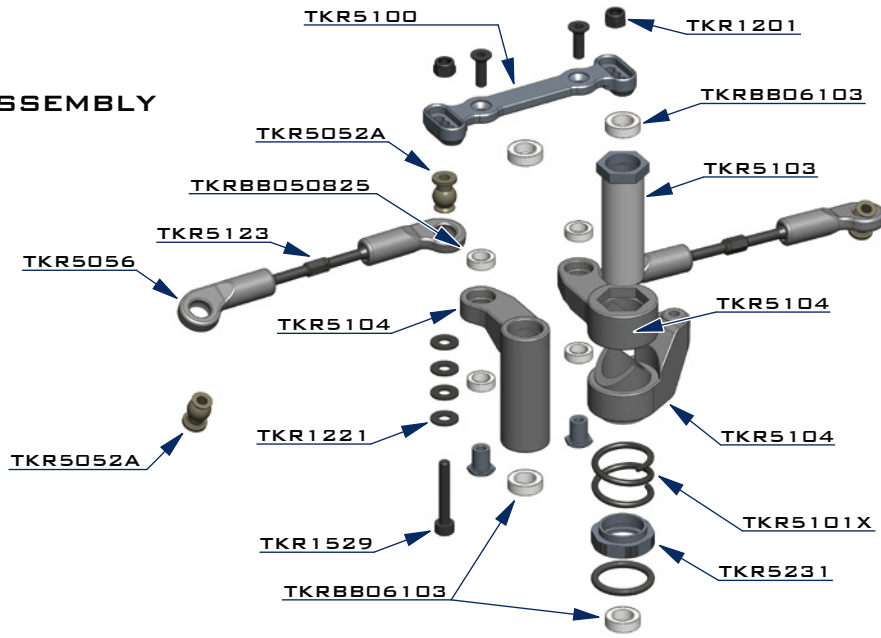

STEP J-1



Note: Tighten nut all the way down, then back it off 3 full turns



* Thread Lock

Note: Apply a small drop of oil for easy o-ring installation.

* Thread Lock

STEP J-2

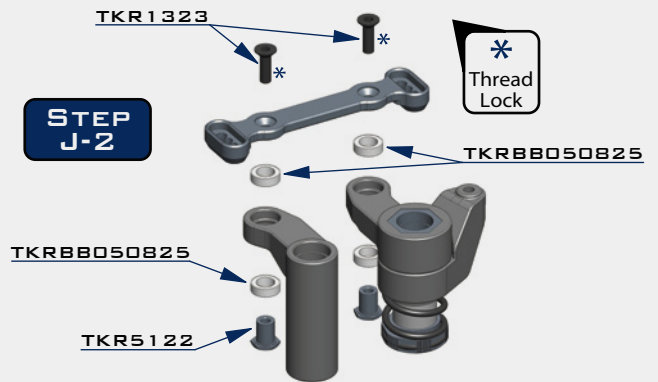

* Thread Lock

x2

TKR1201
M3 LOCK NUT BLACK

x8

TKR1221
M3x8MM WASHER

x2

TKR1323
M3x10MM FLAT HEAD SCREW

x2

TKR1529
M3x20MM CAP HEAD SCREW

x4

TKR5052A
PIVOT BALL M3x6.8MM

x1

TKR5231
O-RING 16x12x2

x4

TKRBB050825
BALL BEARING (5x8x2.5)

x4

TKRBB06103
BALL BEARING (6x10x3)

STEP J-3

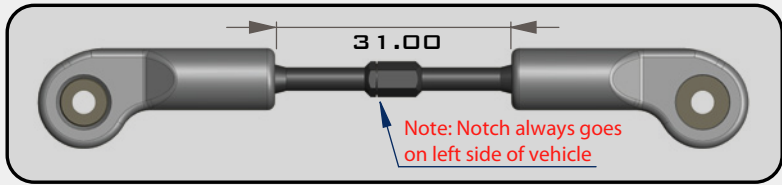

Note: Notch always goes on left side of vehicle

Left

Right

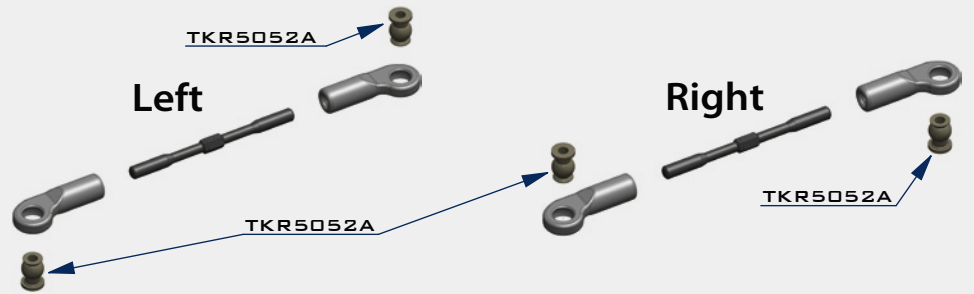

STEP J-4

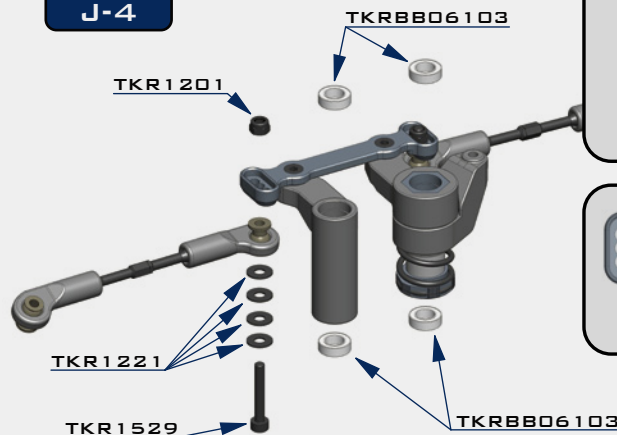

Note: Stock bumpsteer setting is 4 washers under the steering ball link.

4 x TKR1221

Stock Position
(is MIDDLE hole)

BAG K

FRONT END ASSEMBLY

STEP K-1

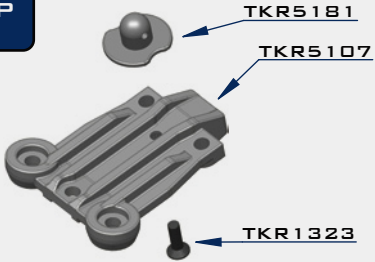

STEP K-2

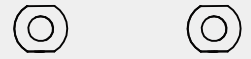
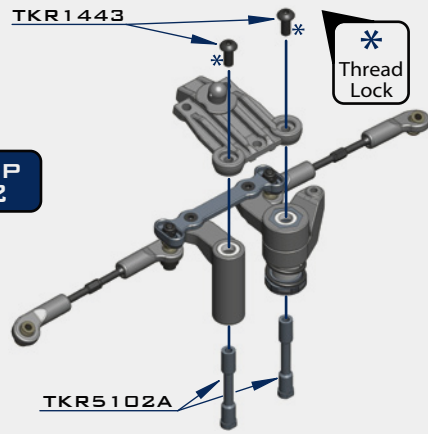

Note Step K-2:
Line up the bottom of the steering posts (TKR5102A) with the corresponding recessed cut in the chassis.

STEP K-3

Note: Initial bumpsteer setting is four washers above the steering ball link.

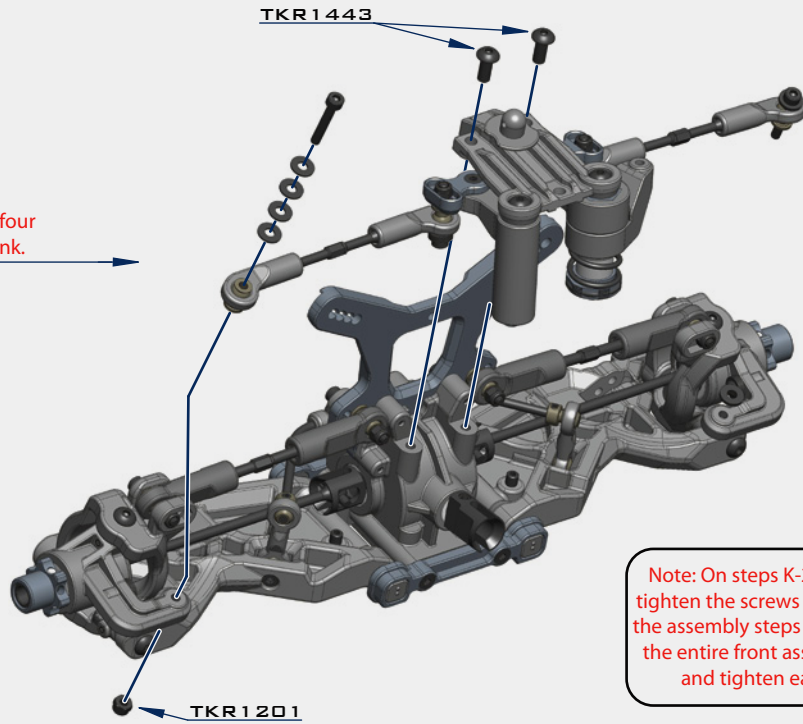

Note: On steps K-2, K-3 and K-4 Do not tighten the screws all the way down until the assembly steps are complete. Position the entire front assembly on the chassis and tighten each screw evenly.

x2
TKR1201
M3 LOCK NUT BLACK

x8
TKR1221
M3X8MM WASHER

x1
TKR1323
M3X10MM FLAT HEAD SCREW

x2
TKR1343
M4X10MM FLAT HEAD SCREW

x6
TKR1344
M4X12MM FLAT HEAD SCREW

x5
TKR1443
M4X10MM BUTTON HEAD SCREW

x1
TKR1522
M3X8MM CAP HEAD SCREW

x2
TKR1529
M3X20MM CAP HEAD SCREW

STEP K-4

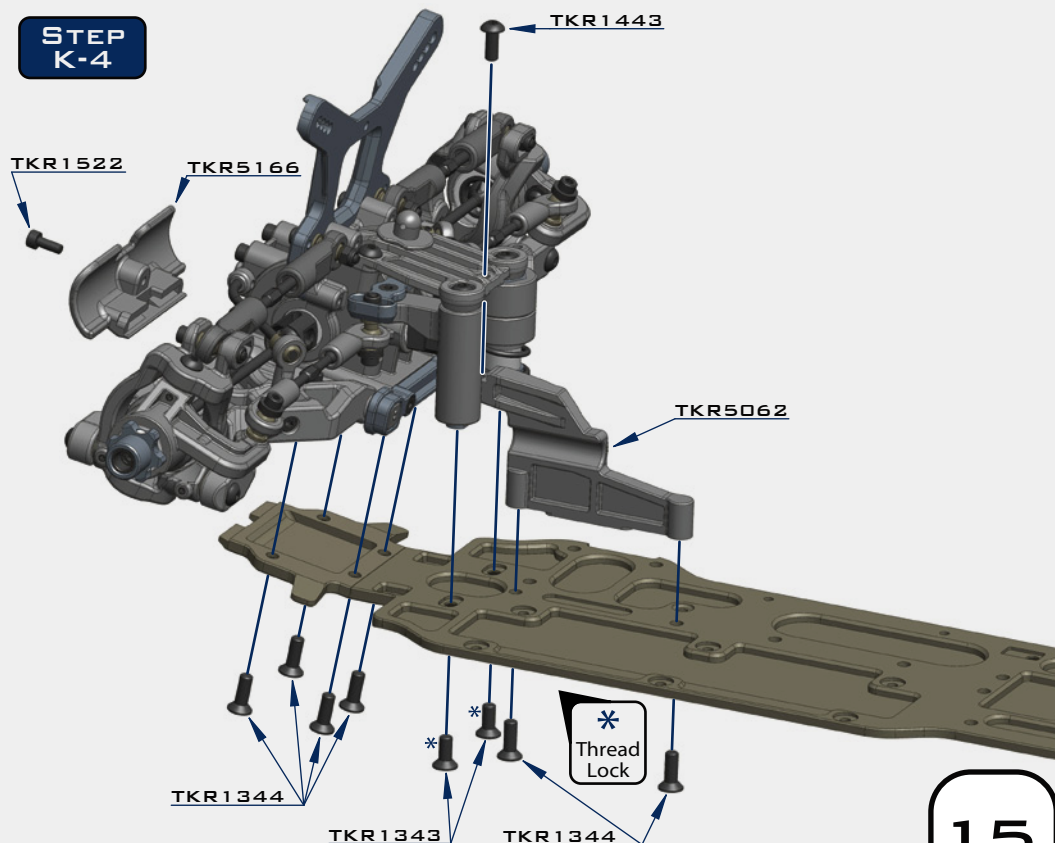

BAG L

CENTER/REAR ASSEMBLY

STEP L-1

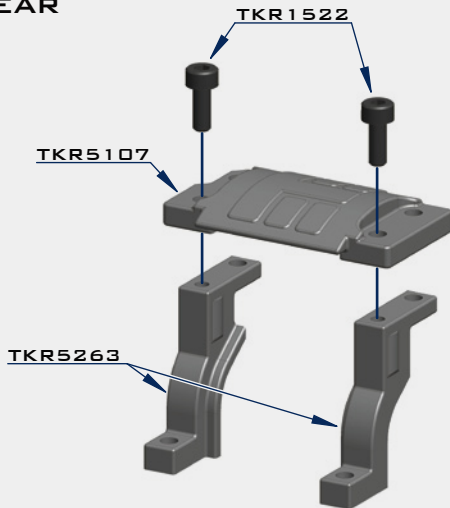

STEP L-2

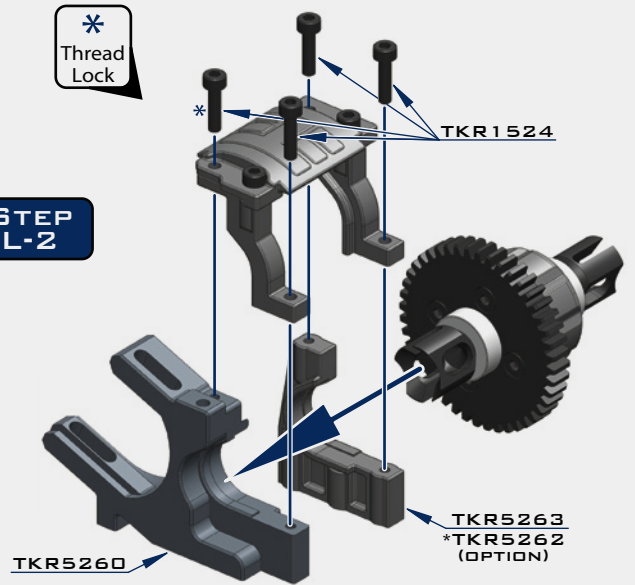

STEP L-3

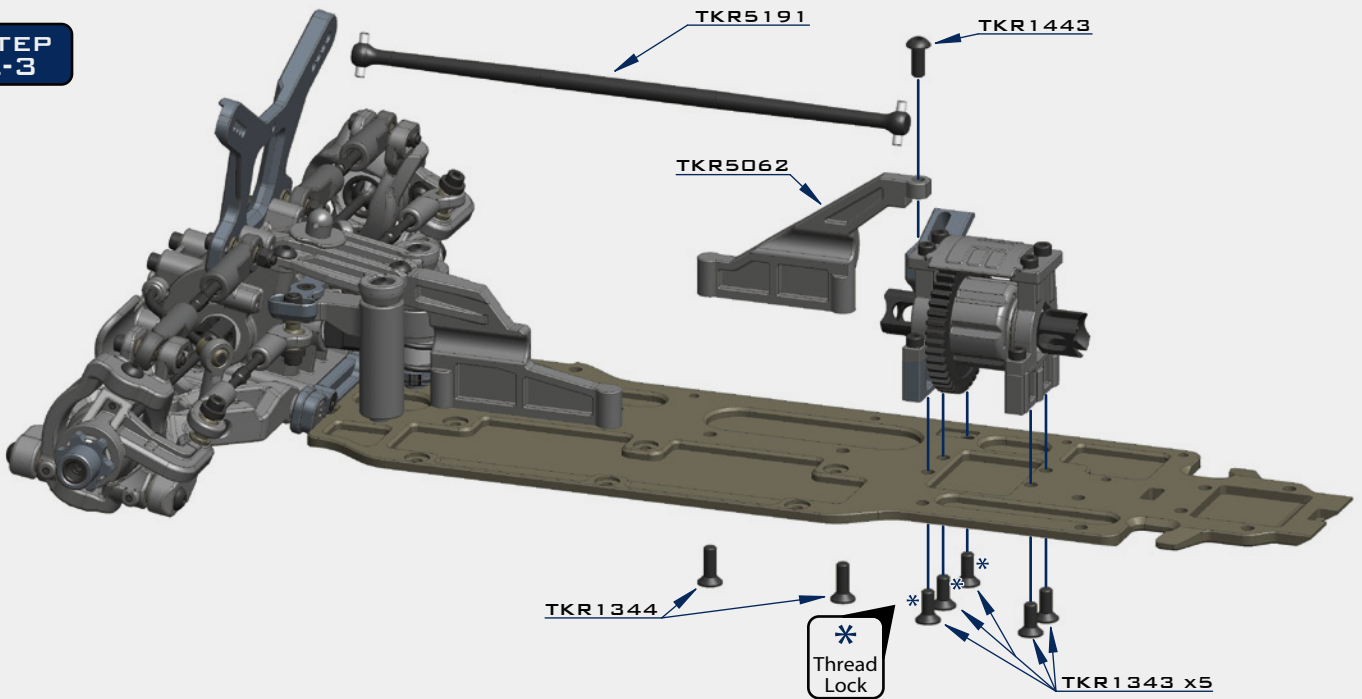

STEP L-4

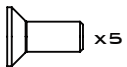
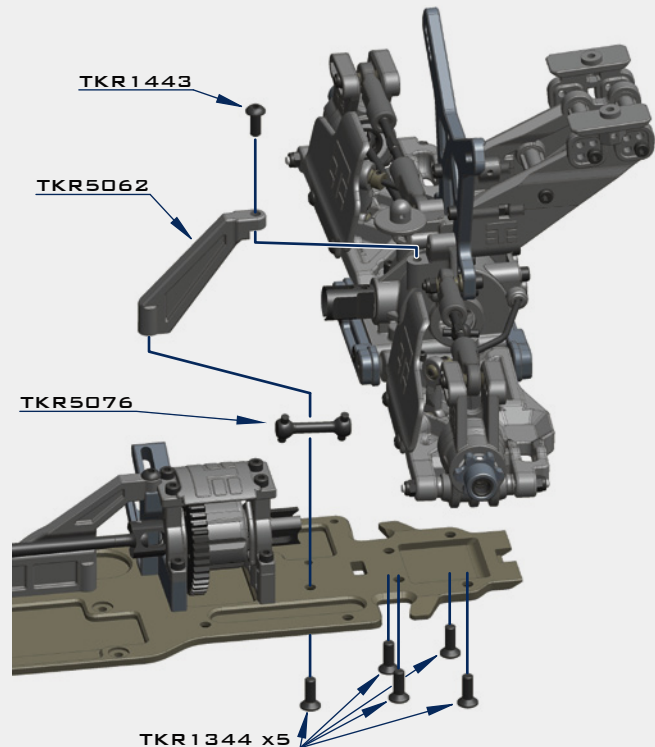

x5
TKR1343
M4x10MM FLAT HEAD SCREW



x7
TKR1344
M4x12MM FLAT HEAD SCREW



x2
TKR1443
M4x10MM BUTTON HEAD SCREW

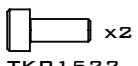

x2
TKR1522
M3x8MM CAP HEAD SCREW

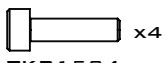

x4
TKR1524
M3x12MM CAP HEAD SCREW

SHOCK FILLING INSTRUCTIONS

FOR BOTH FRONT AND REAR SHOCKS

The following steps and information will provide you with the best way to fill and bleed your shocks. After thorough testing, we've found it's easiest to complete steps 1 through 3 on each shock before moving onto step 4. By the time you've finished step 3 on the last shock the first one will be ready for step 4.

Standard or Vented Cap Build:

Step 1: Extend the shock shaft all the way down. Fill the shock with oil until it is about 90% full.

Step 2: Slowly pump the shock shaft up and down 3-5 times to release air bubbles from underneath the piston.

Step 3: Let the shock rest vertically with the shock shaft fully extended for five minutes or until all the air bubbles have released.

Step 4: Next you will top off the shock with oil, to about 1-2mm below the top edge.

(If you do overfill the shock, it won't hurt performance, it will just spill out and make a little bit of a mess. If you underfill the shock, it will cause air to be trapped inside.)

Step 5: Place the bladder *INSIDE* the shock cap and put a few drops of oil on the bladder.

Step 6: Put a paper towel down below the build to catch drips and have another ready to wipe off excess oil. Place the cap on the shock and screw down about half way. Lay the shock over about 45 degrees with the bleeder hole facing up.

Step 6A: (Standard non-vented) Push the shaft in for the amount of rebound desired.

Step 6B: (Vented "Stock") Push the shaft in until about 15mm of shaft is showing.

- Make sure that you match the rebound amount between the left and right shocks.
- Oil should be oozing out of the bleeder hole.

Step 7: Hold the cap firmly in place with the bleeder hole facing up and turn the shock body until hand tight. The shock will continue to ooze oil.

Step 8: Fully tighten down each shock with shock tools until cap is secure and wipe excess oil away.

Emulsion Build:

Prep your shock caps TKR6018 (optional for EB48) accordingly by drilling out the large angled bleeder hole in the top of the cap. Place the larger thin o-ring around the base of the threads where the shock cap screws on (see diagram on the next page). This seal is crucial to the build.

Follow steps 1-4 above.

Step 5: Rebound is more of a natural side effect of an emulsion shock. It's not something that can be set accurately because you run the risk of hydrolocking the shock if you do not push the shaft all the way in when you bleed it. For now leave the shaft fully extended.

Step 6: Fill the shock up, over filling just slightly without spilling to create a small dome of oil.

Step 7: Place a little bit of oil in the shock cap and quickly put the shock cap on the shock body. Tighten the cap all the way down. Very slowly push the shaft in. Oil will start to bleed out of the top of the cap. While wiping away excess oil, continue to slowly push the shaft in *ALL THE WAY*.

If no oil comes out when the shaft is fully inserted, you will need to start over at step 6.

Step 8: Install the TKR1341 M4x6mm flat head screw and TKR5125 black o-ring to seal the cap (see diagram). Tighten until o-ring is fully seated.

BAG M

FRONT SHOCK ASSEMBLY

STEP M-1

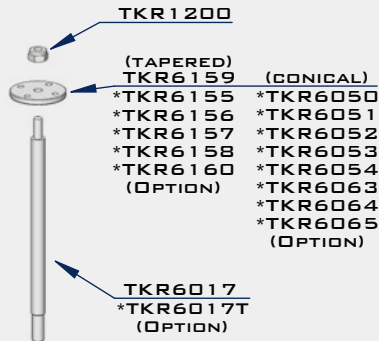
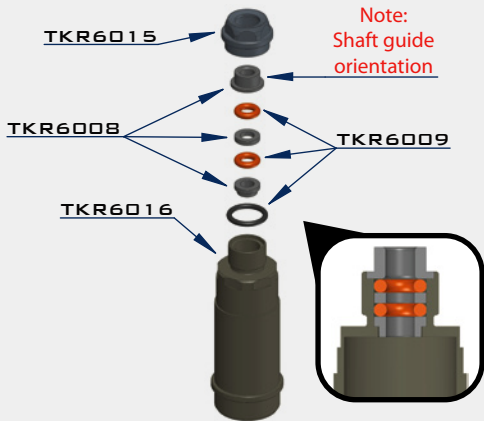

Note: Make sure to tighten both cartridge cap (TKR6015) and shock cap (TKR6003) to ensure a proper seal. Tools may be required.

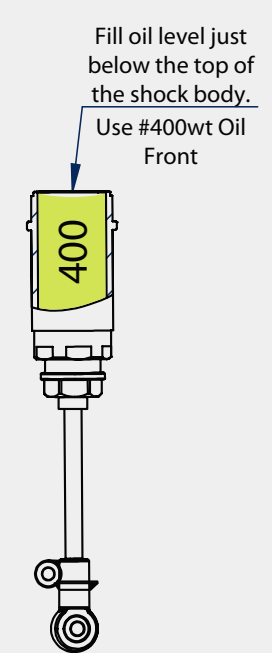
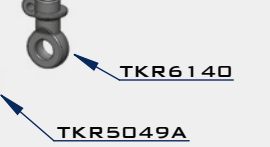
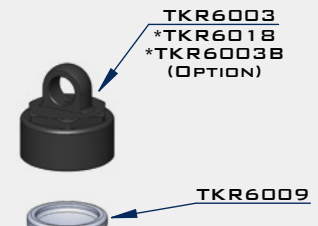

STEP M-2

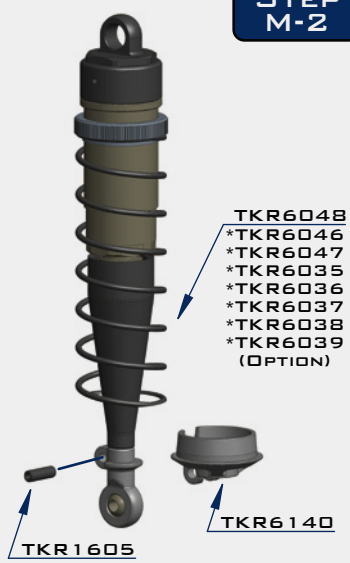

Note: Front shocks use shorter shock bodies - TKR6016, shorter shock shafts - TKR6017, shorter springs - TKR6048 and shorter shock boots - TKR6144

 x2
TKR1200
M2.5 LOCK NUT ZINC

 x2
TKR1202
M4 LOCK NUT BLACK

 x2
TKR1211
M3 LOCK NUT FLANGE BLACK

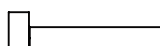
 x2
TKR1240
M3X18MM SHOCK MNT SCREW

 x2
TKR1605
M3X10MM SET SCREW

STEP M-3

 Thread Lock

Note: Slot in spring perch should face outside of vehicle.

TKR1240
Note: Black screw is CW threaded and goes on driver side. Silver screw is CCW and goes on passenger side.

- Stock shock position is outside hole on the arm and 2nd from inside hole on the tower
- Stock front ride height is 27mm
- Shock length (droop) is 120mm

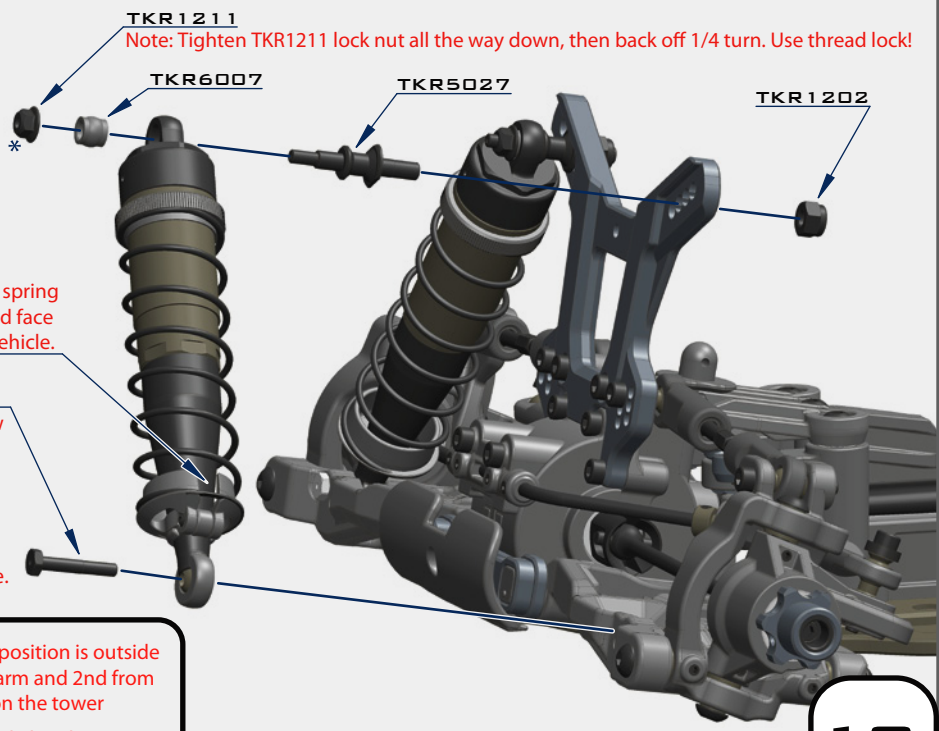

BAG N

REAR SHOCK ASSEMBLY

STEP N-1

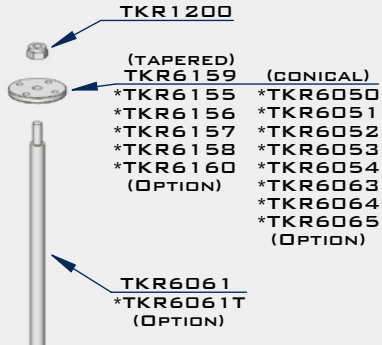
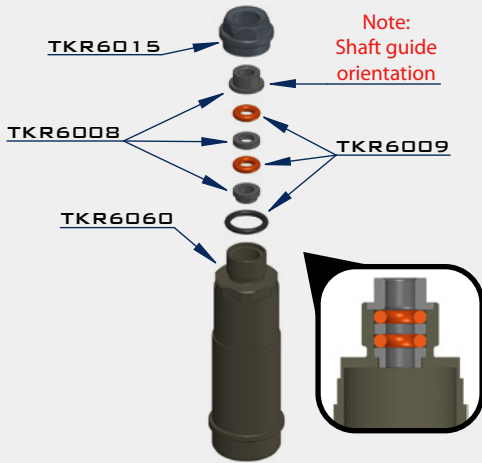

Note: Make sure to tighten both cartridge cap (TKR6015) and shock cap (TKR6003) to ensure a proper seal. Tools may be required.

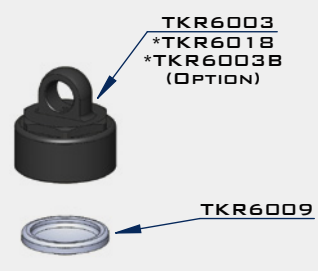

Note: Use green slime or oil on shock shaft threads AND O-rings to prevent tearing and leaking.



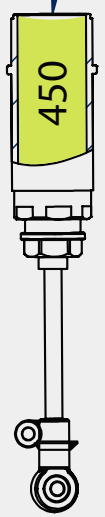

Fill oil level just below the top of the shock body.
Use #450wt Oil Rear

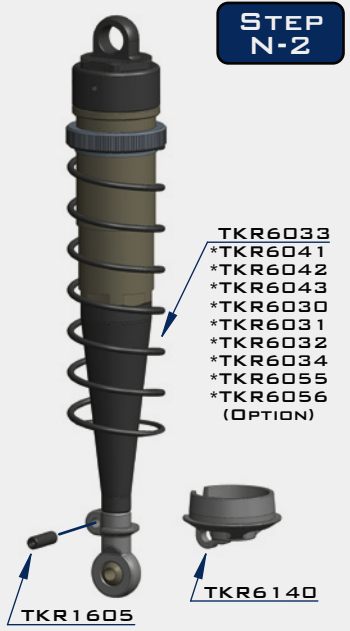

Note: Rear shocks use longer shock bodies - TKR6060, longer shock shafts - TKR6061, longer springs - TKR6033 and longer shock boots - TKR6145

STEP N-2



 x2
TKR1200
M2.5 LOCK NUT ZINC

 x2
TKR1202
M4 LOCK NUT BLACK

 x2
TKR1211
M3 LOCK NUT FLANGE BLACK

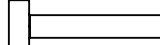
 x2
TKR1240
M3X18MM SHOCK MNT SCREW

 x2
TKR1605
M3X10MM SET SCREW

STEP N-3

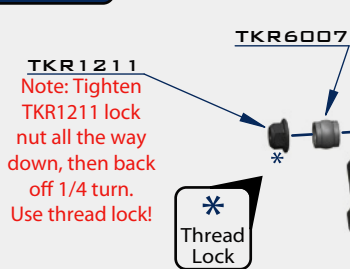

- Stock shock position is inside hole on the arm and 2nd from inside hole on the tower
- Stock rear ride height is 29mm
- Shock length (droop) is 135mm

Note: Slot in spring perch should face outside of vehicle.

TKR1240
Note: Black screw is CW threaded and goes on passenger side. Silver screw is CCW and goes on driver side.

BAG 0

FINAL ASSEMBLY

Steering servo (not included)
 Note: we recommend using a servo with at least 300 oz/in torque.

STEP 0-1

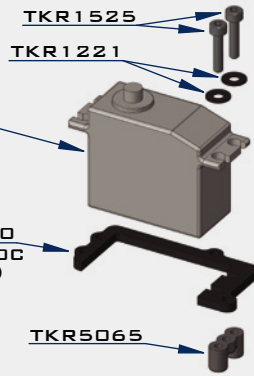

STEP 0-2

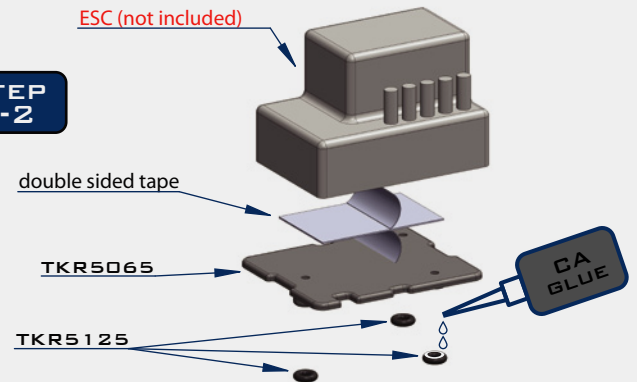

Note: CA glue 3 black o-rings (TKR5125) to the bottom legs of the ESC tray.

STEP 0-3

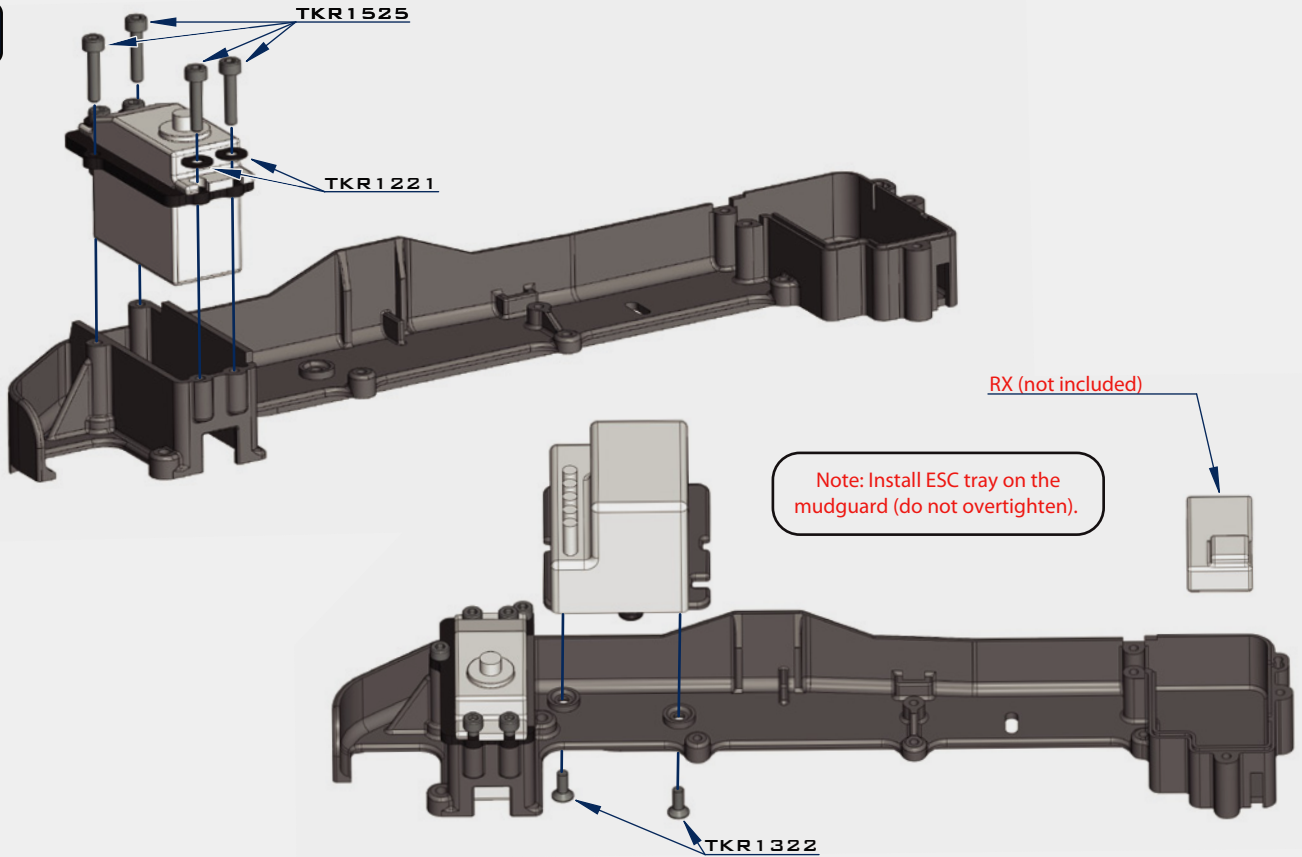

STEP 0-4

Note: Feed the servo wire underneath the esc tray in between the mounting screws on the mud guard, then feed both ESC and servo wires into the RX box as shown. Install wire retainers (TKR5065) to secure them properly.

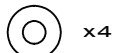
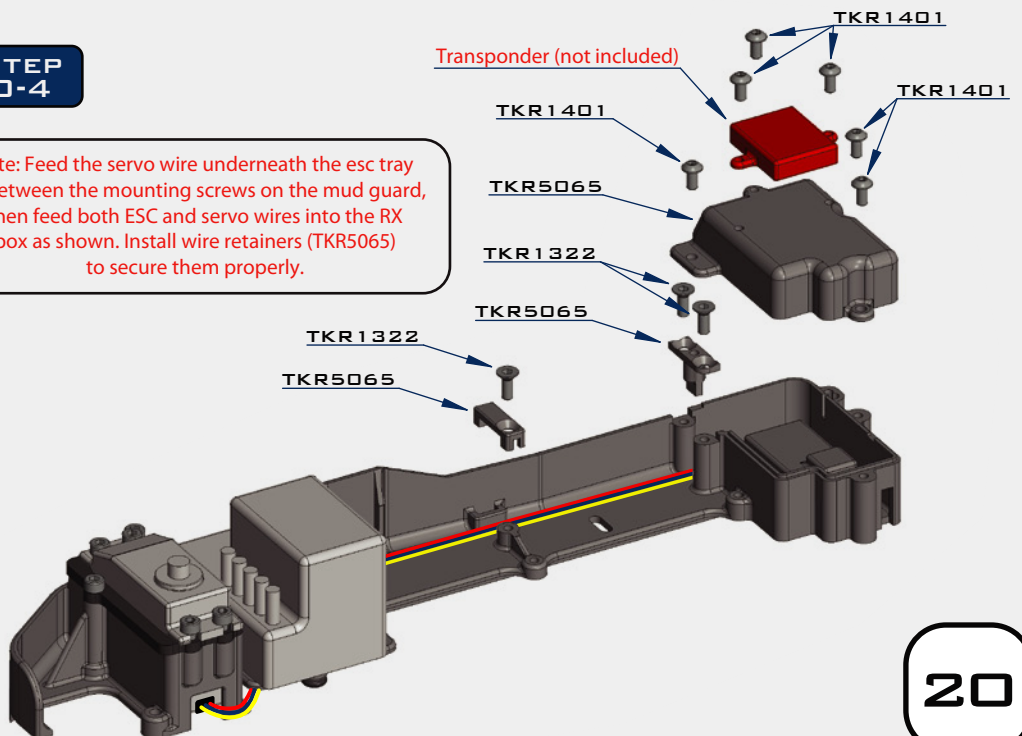

x4

TKR1221
M3X8MM WASHER

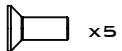

x5

TKR1322
M3X8MM FLAT HEAD SCREW

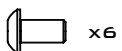

x6

TKR1401
M3X6MM BUTTON HEAD SCREW

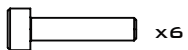

x6

TKR1525
M3X14MM CAP HEAD SCREW



x3

TKR5125
O-RING 3X7MM

BAG P

FINAL ASSEMBLY

STEP P-1

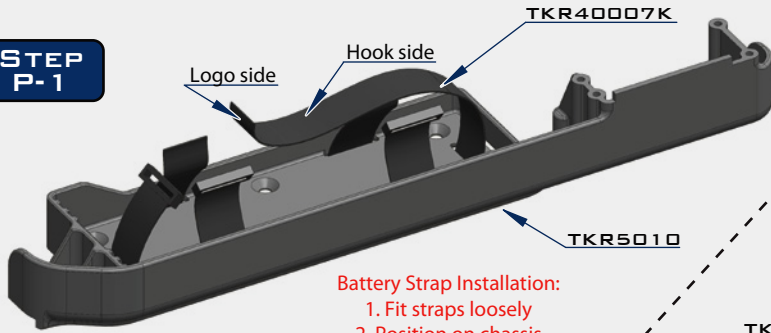

Battery Strap Installation:

1. Fit straps loosely
2. Position on chassis
3. Proceed to step P-2

Motor (not included)

STEP P-2

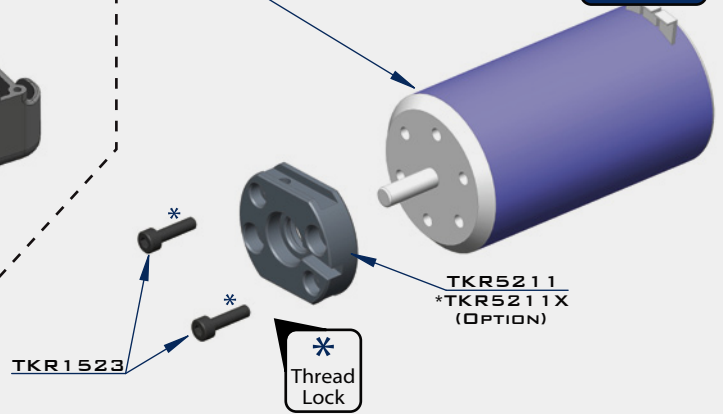

STEP P-3

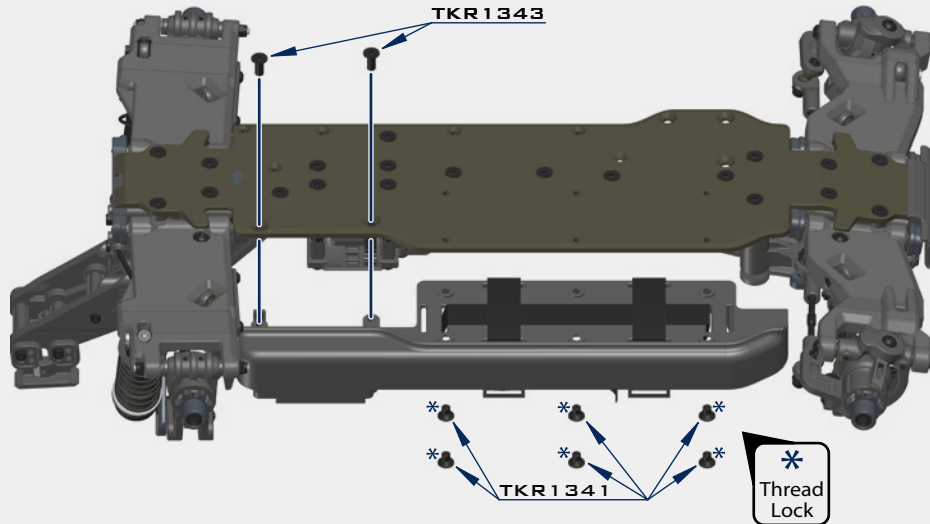

STEP P-4

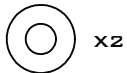
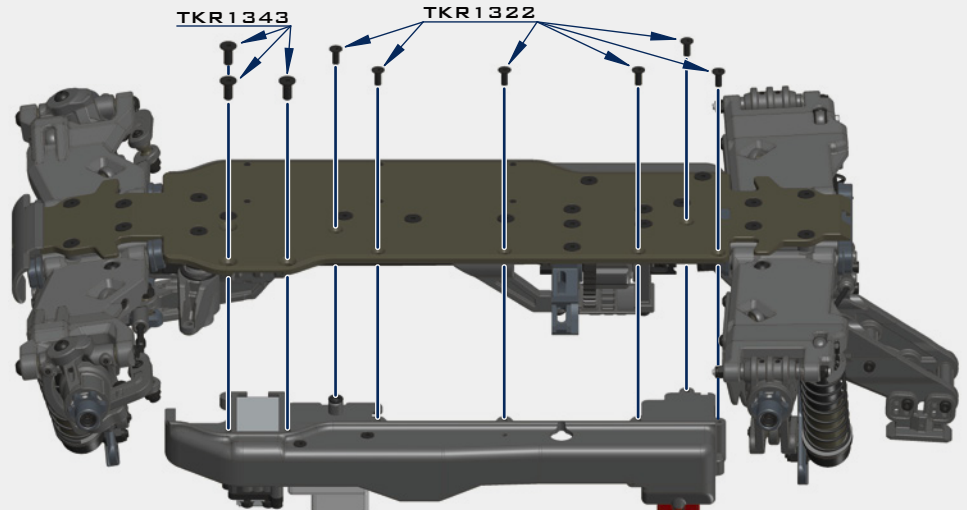

x2

TKR1228
M4 COUNTERSUNK WASHER

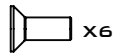

x6

TKR1322
M3X8MM FLAT HEAD SCREW

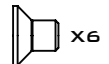

x6

TKR1341
M4X6MM FLAT HEAD SCREW

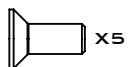

x5

TKR1343
M4X10MM FLAT HEAD SCREW

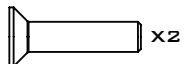

x2

TKR1346
M4X15MM FLAT HEAD SCREW

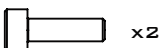

x2

TKR1523
M3X10MM CAP HEAD SCREW

STEP P-5

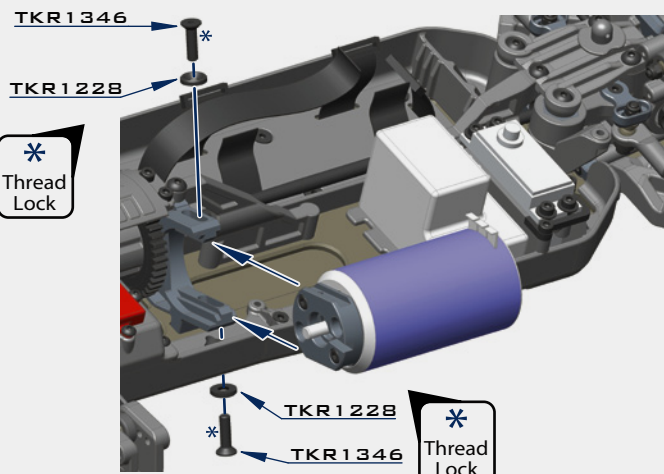

Note: Install MOD1 pinion (TKR4171-4190) at this step. Adjust gear mesh and tighten screws (TKR1346) well. *Use thread lock.

BAG P

FINAL ASSEMBLY

**STEP
P-6**

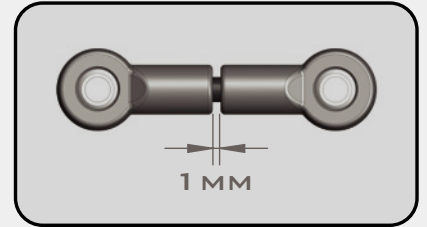
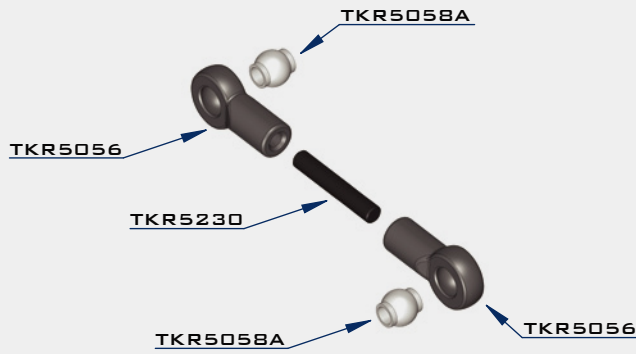

**STEP
P-7**

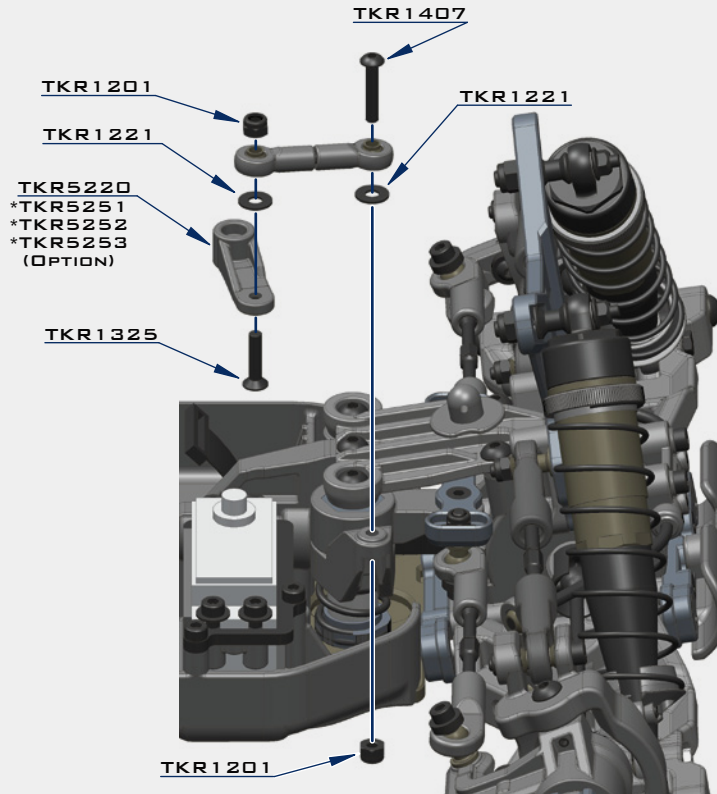



 x2
TKR1201
M3 LOCK NUT BLACK

 x2
TKR1221
M3X8MM WASHER

 x1
TKR1325
M3X14MM FLAT HEAD SCREW

 x1
TKR1407
M3X16MM BUTTON HEAD SCREW

 x2
TKR5058A
PIVOT BALL M3X5.8MM
NO FLANGE

 x1
TKR5230
M3X18 THREADED ROD

**STEP
P-8**

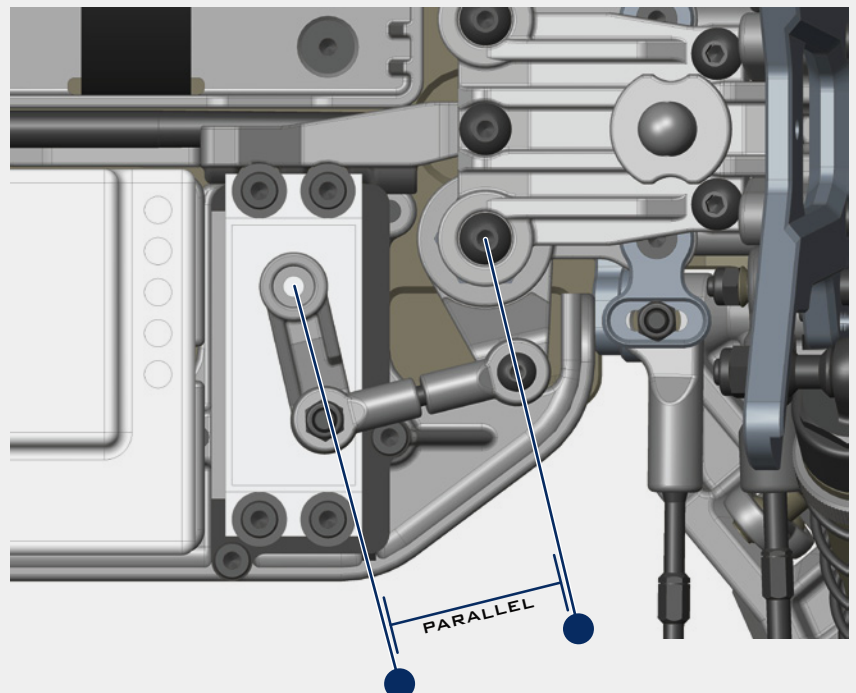

Note: Offset servo arm so it is parallel with the connecting arm at neutral or zero servo position.

BAG Q

WING/WHEELS/BODY

STEP Q-1

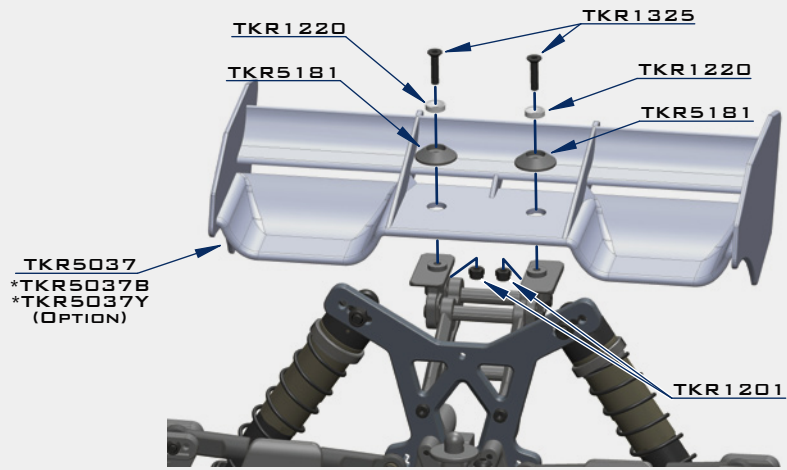



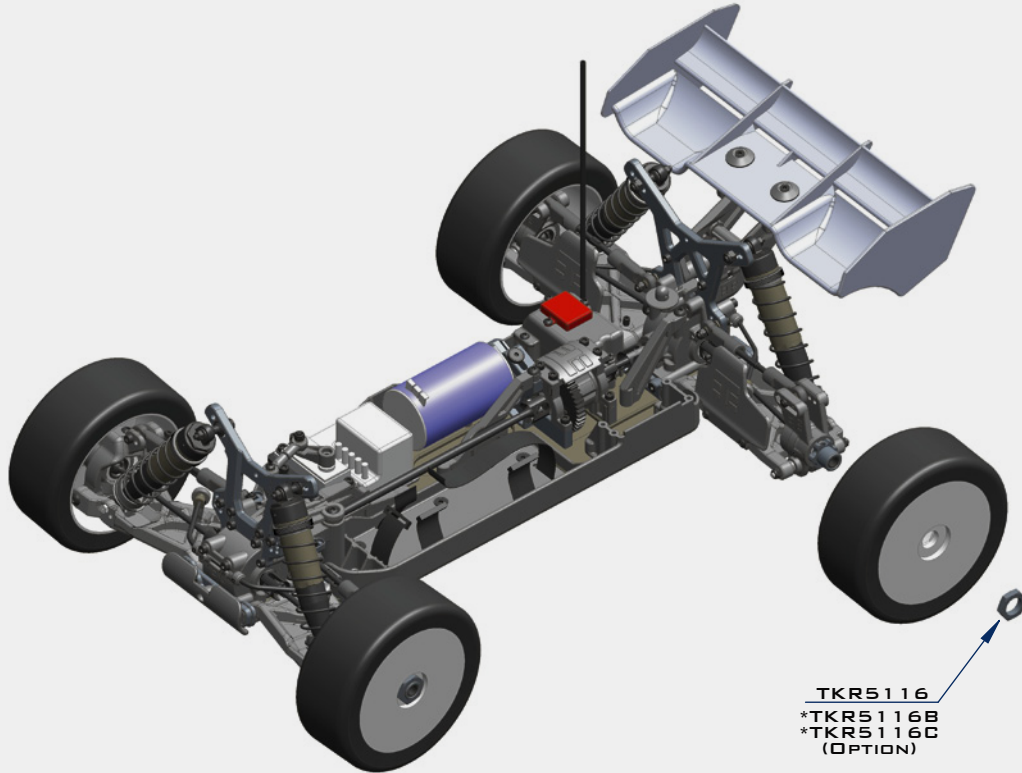

STEP Q-2

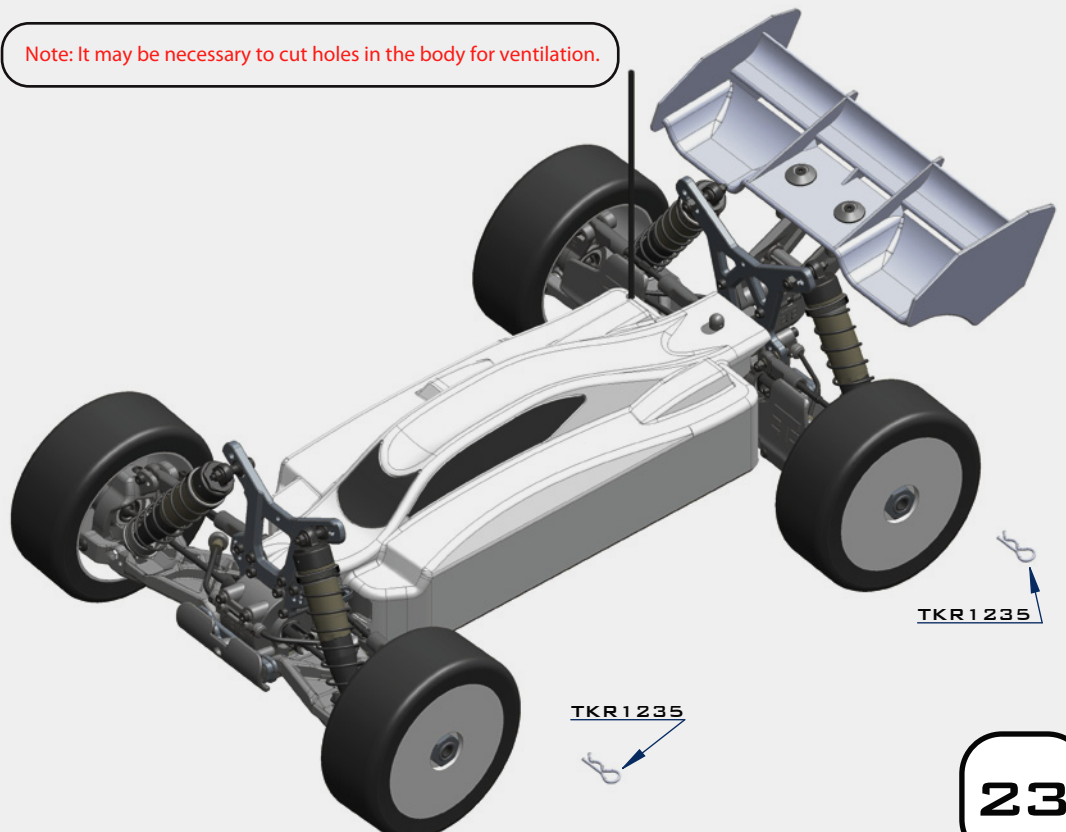

STEP Q-3

Note: It may be necessary to cut holes in the body for ventilation.

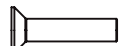

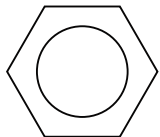
-  x2
TKR1201
M3 LOCK NUT BLACK
-  x2
TKR1220
M4 COUNTERSUNK WASHER
-  x2
TKR1325
M3X14MM FLAT HEAD SCREW
-  x2
TKR1235
BODY CLIP
-  x4
TKR5116
WHEEL NUT

TKR5005 - EB48.3 1/8th Competition Electric Buggy Kit

Parts List

TKR4007K – Battery Straps (EB48, black, 4 cell, 3pcs)
TKR5006 - Chassis (7075, hard anodized)
TKR5010 – Battery Tray, Mud Guard (EB48, left side)
TKR5011 – Radio Tray, Mud Guard (EB48, right side)
TKR5012 – Gearbox (front)
TKR5016B – Gearbox (rear, angled)
TKR5020 – Hinge Pins (inner, front/rear)
TKR5027 – Shock Standoffs (2pcs)
TKR5034 – Hinge Pins (outer, rear)
TKR5037 – Wing (white)
TKR5049A – Pivot Balls (6.8mm, no flng, sway bar, shck ends, almmn, 4pcs)
TKR5052A – Pivot Balls (6.8mm, inside camber, steering links, aluminum, 4pcs)
TKR5053A – Pivot Balls (6.8mm, flanged, outside camber, aluminum, 4pcs)
TKR5054A – Spindle Bushings (4pcs, aluminum, hard ano)
TKR5055A – Arm Bushings (4pcs, aluminum, hard ano)
TKR5056 – Rod Ends (5.8mm, brake/steering/sway bar linkage, 8pcs)
TKR5058A – Pivot Balls (5.8mm, no flange, brake/steering link, aluminum, 4pcs)
TKR5060 – Steering Servo Brace (aluminum, gun metal ano)
TKR5062 – Chassis Brace Set (front/rear/center)
TKR5065 – ESC Tray and Radio/Battery Tray Accessories
TKR5070 – Stub Axles (hardened steel, 2pcs)
TKR5071X – Wheel Hubs (17mm, aluminum, lightened, gun metal ano, w/pins, 2pcs)
TKR5072 – Driveshafts (f/r, hardened steel, 2pcs)
TKR5073 – CV Rebuild kit (f/r, for 2 axles)
TKR5075 – Diff Coupler (f/r, hardened steel)
TKR5076 – Driveshaft (center, rear, hardened steel)
TKR5079A – Stabilizer Balls (6.8mm, sway bars, aluminum, 4pcs)
TKR5082 – Sway Bar (2.4mm, front)
TKR5086 – Sway Bar Mounts
TKR5100 – Ackerman Plate (aluminum, gun metal ano)
TKR101X - Servo Saver Spring (HD, EB48, SCT410, NB48)
TKR5102A – Steering Posts (aluminum)
TKR5103 – Servo Saver Post (aluminum, gun metal ano)
TKR5104 – Steering Bell Cranks
TKR5107 – Steering Top Plate, Center Diff Top Plate, Center Diff Rear Support
TKR5116 – Wheel Nuts (17mm, serrated, gun metal ano, M12x1.0, 4pcs)
TKR5122 – Steering Rack Bushings (aluminum, gun metal ano, 2pcs)
TKR5123 – Turnbuckle (steering links, 2pcs)
TKR5125 – O-Ring (ESC tray, 3pcs)
TKR5126 – Antenna tube (universal, w/ caps, 5pcs)
TKR5161 - V2 Adj. Hinge Pin Brace ("A" block, 7075, EB/NB/ET/NT/SCT)
TKR5162 - V2 Adj. Hinge Pin Brace ("B" block, 7075, EB/NB/ET/NT/SCT)
TKR5163 - V2 Adj. Hinge Pin Brace ("C" block, 7075, EB/NB/ET/NT/SCT)
TKR5164 - V2 Adj. Hinge Pin Brace ("D" block, 7075, EB/NB/ET/NT/SCT)
TKR5165 - V2 Hinge Pin Inserts, Wheelbase Shims (EB/NB/ET/NT/SCT)
TKR5166 - Front Bumper (revised, EB/NB/ET/NT48)
TKR5174 - Rear Arm Mud Guards (for TKR5184, EB/NB)
TKR5181 - Low Profile Wing Mount and Body Mounts (EB/NB48/EB48SL)
TKR5184 - Suspension Arms (rear, EB/NB48.3)
TKR5187 - Rod Ends (straight, 6.8mm, EB/NB/ET/NT48, 8pcs)
TKR5191 - Tapered Driveshaft (EB48, ET48, center, front, 7075 aluminum, black ano)
TKR5193 - Spindles (trailing, L/R, requires TKR5194, EB/NB/ET/NT48, EB/NB.3)
TKR5194 - Spindle Carriers (trailing, 15 degree, L/R, EB/NB/ET/NT48, EB/NB.3)
TKR5199 - Rear Hubs (L/R, CV or uni, EB/NB/ET/NT48, EB/NB.3)
TKR5211 – Motor Mount Insert (aluminum, gun metal ano)
TKR5220 – Servo Horns (steering, brakes)
TKR5230 – Steering linkage (M3x18mm threaded rod, 10pcs)
TKR5231 – Servo Saver Nut and Spring
TKR5245 – Body (.040 lexan, EB48)
TKR5259 - Decal Sheet (EB48.3)
TKR5260 - CNC Split Cntr Diff Mount (mtr mnt only, 7075, gun metal ano, EB/ET/SCT)
TKR5263 - Split Cntr Diff Mount (composite, requires TKR5260, EB/ET/SCT/SL)
TKR5268 - Shock Tower (front, 7075 CNC, gun metal ano, EB/NB48.3)
TKR5269 - Shock Tower (rear, 7075 CNC, gun metal ano, EB/NB48.3)
TKR5286 - Suspension Arms (front, EB/NB48.3)
TKR5491 - Sway Bar (2.4mm, rear)

Differential List

TKR5112X – Differential Outdrives (center, lightened)
TKR5113 – Differential Case (f/c/r)
TKR5114X – Differential Outdrives (f/r, lightened)
TKR5143 – Differential Seals (3pcs)
TKR5144 – Differential O-Rings (6pcs)
TKR5145B – Differential Shims (revised, 6x17mm, 6pcs)
TKR5149 – Differential Cross Pins (steel, 6pcs)
TKR5150 – Differential Gear Set (internal gears only)
TKR5151 – Differential Ring Gear (40t, straight cut)
TKR5152 – Diff Pinion (10T, straight cut)
TKR5237K – Spur Gear (44t, black, composite)

Shocks List

TKR6003 – Vented Shock Caps (aluminum, black ano, 2pcs)
TKR6007 - Shock Cap Bushings (4pcs, EB/NB/ET/NT/SCT)
TKR6008 – Shock Shaft Guide, Piston, and Bushing Set (for 2 shocks)
TKR6009 – Shock O-Ring and Bladder Set (for 2 shocks)
TKR6013 – Shock Adjustment Nuts (aluminum, gun metal ano, 2pcs)
TKR6015 – Shock Cartridge Caps (aluminum, gun metal ano, 2pcs)
TKR6016 – Shock Body (rear, aluminum, hard ano, 2pcs)
TKR6017 – Shock Shafts (rear, steel, 2pcs)
TKR6033 – Shock Spring Set (rear, 1.4 x 9.5T, 85mm, orange)
TKR6048 – Shock Spring Set (front, 1.5 x 9.5T, 65mm, black)
TKR6060 – Shock Body (rear, x-long, aluminum, hard ano, 2pcs)
TKR6061 – Shock Shafts (rear, x-long, steel, 2pcs)
TKR6140 - Locking Shock Rod End and Spring Perch Set (EB/NB/ET/NT/SCT)
TKR6144 - Shock Boots (long length, EB/NB, 2pcs)
TKR6145 - Shock Boots (X-long length, rear EB/NB, 2pcs)

Bearings List

TKRBB050825 – Ball Bearing (5x8x2.5mm, 4pcs)
TKRBB05114 – Ball Bearing (5x11x4, 4pcs)
TKRBB05134 – Ball Bearing (5x13x4, 4pcs)
TKRBB06103 – Ball Bearing (6x10x3, 4pcs)
TKRBB08165 – Ball Bearing (8x16x5, 4pcs)
TKRBB13194 – Ball Bearing (13x19x4, 4pcs)

Hardware List

TKR1200 – M2.5 Locknuts (zinc finish, 10pcs)
TKR1201 – M3 Locknuts (black, 10pcs)
TKR1202 – M4 Locknuts (black, 10pcs)
TKR1211 – M3 Locknuts (flanged, black, 10pcs)
TKR1220 – M3 Countersunk Washers (aluminum, natural, 10pcs)
TKR1221 – M3x8mm Washer (black, 10pcs)
TKR1222 – 13x16x.1mm Diff Shims (10pcs)
TKR1226 – 5x7x2mm shims (10pcs)
TKR1228 - M4 Countersunk Washer (black, 10pcs)
TKR1235 – Body Clips (10pcs)
TKR1238 - Droop Adjustment Screws (M4x10mm, 8pcs)
TKR1240 - Lower Shock Mount Screws (2 CW thread, 2 CCW thread, EB/NB/SCT)
TKR1322 – M3x8mm Flat Head Screws (black, 10pcs)
TKR1323 – M3x10mm Flat Head Screws (black, 10pcs)
TKR1325 – M3x14mm Flat Head Screws (black, 10pcs)
TKR1327 – M3x16mm Flat Head Screws (black, 10pcs)
TKR1333 - M3x40mm Flat Head Screws (black, 10pcs)
TKR1341 - M4x6mm Flat Head Screws (black, 10pcs)
TKR1343 - M4x10mm Flat Head Screws (black, 10pcs)
TKR1344 - M4x12mm Flat Head Screws (black, 10pcs)
TKR1346 - M4x15mm Flat Head Screws (black, 10pcs)
TKR1401 - M3x6mm Button Head Screws (black, 10pcs)
TKR1402 - M3x8mm Button Head Screws (black, 10pcs)
TKR1407 - M3x16mm Button Head Screws (black, 10pcs)
TKR1443 - M4x10mm Button Head Screws (black, 10pcs)
TKR1445 - M4x14mm Button Head Screws (black, 10pcs)
TKR1447 - M4x16mm Button Head Screws (black, 10pcs)
TKR1522 - M3x8mm Cap Head Screws (black, 10pcs)
TKR1523 - M3x10mm Cap Head Screws (black, 10pcs)
TKR1524 - M3x12mm Cap Head Screws (black, 10pcs)
TKR1525 - M3x14mm Cap Head Screws (black, 10pcs)
TKR1529 - M3x20mm Cap Head Screws (black, 10pcs)
TKR1601 - M3x4mm Set Screws (black, 10pcs)
TKR1603 - M5x4mm Set Screws (black, 10pcs)
TKR1605 - M3x10mm Set Screws (black, 10pcs)

Option Parts

TKR1103 - Turnbuckle Wrench (4mm, 5mm, hardened steel)
TKR1116 - 17mm Wheel Wrench, Shock Cap Tool
TKR1119 - 5.5mm / 7.0mm Wrench (hardened steel)
TKR5037B – Wing (black)
TKR5037Y – Wing (yellow)
TKR5060C – Steering Servo Brace (carbon fiber)
TKR5070A – Stub Axles (Aluminum, 2pcs)
TKR5071B – Wheel Hubs (17mm, alum, ltnd, gun metal ano, 1mm off, w/pins, 2pcs)
TKR5071C – Wheel Hubs (17mm, alum, ltnd, gun metal ano, 2mm off, w/pins, 2pcs)
TKR5080 – Sway Bar (f/r, 2.2mm)
TKR5081 – Sway Bar (f/r, 2.3mm)
TKR5083 – Sway Bar (f/r, 2.5mm)
TKR5084 – Sway Bar (f/r, 2.6mm)
TKR5085 – Sway Bar (f/r, 2.8mm)
TKR5087 – Sway Bar (f/r, 3.0mm)
TKR5149A - Diff Cross Pins (aluminum, 6pcs, requires TKR5150)
TKR5199A - Aluminum Rear Hubs (gun metal ano, EB/NB/ET/NT, 2pcs)
TKR5211X – Motor Mount Insert (aluminum, lightened, gun metal ano)
TKR5237 – Spur Gear (44t, composite, natural color)
TKR5251 – Aluminum Servo Horn (23t spline, Airtronics/JR/KO Servos)
TKR5252 – Aluminum Servo Horn (24t spline, Hitec Servos)
TKR5253 – Aluminum Servo Horn (25t spline, Futaba/Pro-Tek/Savox Servos)
TKR5261 - CNC Split Cntr Diff Mnt (complete, 7075, gun metal ano, EB/ET/SCT)
TKR5262 - CNC Split Cntr Diff Mount (diff mounts only, 7075, gun metal ano, EB/ET/SCT)
TKR5490 – Sway Bar (rear, 2.3mm)
TKR5492 – Sway Bar (rear, 2.5mm)
TKR5493 – Sway Bar (rear, 2.6mm)
TKR5494 – Sway Bar (rear, 2.8mm)
TKR5495 – Sway Bar (rear, 3.0mm)
TKR6003B – Non-Vented Shock Caps (aluminum, black ano, 2pcs)
TKR6009B – Shock O-Ring Set (16pcs)
TKR6017T – Shock Shafts w/ TiNi coating (rear, steel, 2pcs)
TKR6018 – Shock Cap and Spring Adjuster Set (composite, for 2 shocks)
TKR6030 – Shock Spring Set (rear, 1.4 x 11.0T, 85mm, pink)
TKR6031 – Shock Spring Set (rear, 1.4 x 10.5T, 85mm, yellow)
TKR6032 – Shock Spring Set (rear, 1.4 x 10.0T, 85mm, green)
TKR6034 – Shock Spring Set (rear, 1.4 x 9.0T, 85mm, red)
TKR6035 – Shock Spring Set (front, 1.5 x 9.0T, 70mm, pink)
TKR6036 – Shock Spring Set (front, 1.5 x 8.5T, 70mm, green)
TKR6037 – Shock Spring Set (front, 1.5 x 8.0T, 70mm, yellow)
TKR6038 – Shock Spring Set (front, 1.5 x 7.5T, 70mm, orange)
TKR6039 – Shock Spring Set (front, 1.5 x 7.0T, 70mm, red)
TKR6041 – Shock Spring Set (rear, 1.4 x 12.5T, 80mm, white)
TKR6042 – Shock Spring Set (rear, 1.4 x 12.0T, 80mm, grey)
TKR6043 – Shock Spring Set (rear, 1.4 x 11.5T, 80mm, black)
TKR6046 – Shock Spring Set (front, 1.5 x 10.5T, 65mm, white)
TKR6047 – Shock Spring Set (front, 1.5 x 10.0T, 65mm, grey)
TKR6050 - Shock Pistons (CNC, conical, 10x1.1mm)
TKR6051 - Shock Pistons (CNC, conical, 8x1.3mm)
TKR6052 - Shock Pistons (CNC, conical, 10x1.2mm)
TKR6053 - Shock Pistons (CNC, conical, 8x1.4mm)
TKR6054 - Shock Pistons (CNC, conical, 10x1.3mm)
TKR6055 – Shock Spring Set (rear, 1.4 x 8.5T, 80mm, blue)
TKR6056 – Shock Spring Set (rear, 1.4 x 8.0T, 80mm, purple)
TKR6061T – Shock Shafts w/ TiNi coating (rear, x-long, steel, 2pcs)
TKR6063 – Shock Pistons (CNC, conical, 6x1.5, 10.6mm²)
TKR6064 – Shock Pistons (CNC, conical, 6x1.6, 12.1mm²)
TKR6065 – Shock Piston Blanks (CNC, conical, 16 dimples, 16mm)
TKR6146 – Shock Cartridge Set (CNC, Delrin, EB/NB/ET/NT/SCT)
TKR6155 - Shock Pistons (CNC, tapered, 8x1.3mm)
TKR6156 - Shock Pistons (CNC, tapered, 7x1.4mm)
TKR6157 - Shock Pistons (CNC, tapered, 6x1.5mm)
TKR6158 - Shock Pistons (CNC, tapered, 5x1.7mm)
TKR6159 - Shock Pistons (CNC, tapered, 4x1.8mm)
TKR6160 - Shock Piston Blanks (CNC, tapered, 16 dimples)

Name: Box Stock Date: _____ Event: _____

Track: Indoor Outdoor Size: Small Medium Large Traction: Low Med High

Surface: Smooth Bumpy Rutted Type: Loose/Loamy Hard Pack Blue Groove Clay

Bumpsteer/Ackerman/Servo Saver/Steering Stop: _____ Condition: Dusty Dry Wet Muddy

ballstud orientation

washers over # 0

washers under # 4

washers over # 4

washers under # 0

ballstud orientation

front middle rear

Front End:

OFFSET: 0mm, 1mm, 2mm

"A" Block

(0° WITH CENTER DOT INSERT)

(Sweep)

"B" Block

(10° WITH CENTER DOT INSERT)

(Kick Up)

Rear End:

OFFSET: 0mm, 1mm, 2mm

"C" Block

(2° WITH CENTER DOT INSERT)

(Anti-Squat)

"D" Block

(3° WITH CENTER DOT INSERT)

(Rear Toe)

Turns from fully tight: 3

of washers: 3

Suspension:

	FRONT	REAR
RIDE HEIGHT	27	29
CAMBER	-2 deg	-2 deg
CASTER	15 deg	
SWEEP	0 deg	
KICK UP	8.5 deg	
ANTI-SQUAT		2 deg
TOE (in/out)	.5 deg out	3 deg
SWAY BAR	2.4mm	2.4mm
SHOCK LENGTH (DROOP)	120	135

Body/Wing:

BODY MAKE	stock
WING MAKE	stock

POSITION SETTINGS

1 - REARWARD LOW 2 - FOREWARD LOW

3 - REARWARD HIGH 4 - FOREWARD HIGH

DOWNFORCE SETTINGS

4° 7° 10°

(downforce angles)

Wheelbase:

large 2mm small 1mm

3 mm / FRONT

2 mm / REAR

Shocks:

	FRONT	REAR
OIL	400	450
BRAND		
PISTON	4x 1.8 flat	4x 1.8 flat
SPRING	black	orange
REBOUND	0 %	0 %
STD/EMUL/VENT	vent	vent

NOTES:

Tires/Wheels:

	FRONT	REAR
BRAND/TREAD		
COMPOUND		
INSERT		
WHEEL		

NOTES:

Differential Oil:

FRONT	CENTER	REAR
5k	5k	5k

Electronics:

ESC:	
BATTERY:	
MOTOR:	
RADIO:	
SERVO:	300oz/in min

Drivetrain:

PINION SIZE		(teeth)
-------------	--	---------

Chassis Braces:

Front Middle Rear

(front brace is always recommended)

Notes:

Name: _____ Date: _____ Event: _____

Track: Indoor Outdoor Size: Small Medium Large Traction: Low Med High

Surface: Smooth Bumpy Rutted Type: Loose/Loamy Hard Pack Blue Groove Clay

Bumpsteer/Ackerman/Servo Saver/Steering Stop: _____ Condition: Dusty Dry Wet Muddy

Washers over # washers under #

ballstud orientation

ballstud orientation

front middle rear

Front End:

OFFSET: 0mm, 1mm, 2mm

"A" Block

(Sweep) (0° WITH CENTER DOT INSERT)

"B" Block

(Kick Up) (10° WITH CENTER DOT INSERT)

Rear End:

OFFSET: 0mm, 1mm, 2mm

"C" Block

(Anti-Squat) (2° WITH CENTER DOT INSERT)

"D" Block

(Rear Toe) (3° WITH CENTER DOT INSERT)

0° (OFFSET) 5° 1° 5° 1° 1° 5° 5° 1°

Turns from fully tight # of washers

Suspension:

	FRONT	REAR
RIDE HEIGHT		
CAMBER		
CASTER		
SWEEP		
KICK UP		
ANTI-SQUAT		
TOE (in/out)		
SWAY BAR		
SHOCK LENGTH (DROOP)		

Body/Wing:

BODY MAKE	
WING MAKE	

POSITION SETTINGS

1 - REARWARD LOW 2 - FOREWARD LOW
3 - REARWARD HIGH 4 - FOREWARD HIGH

DOWNFORCE SETTINGS

(downforce angles)

Wheelbase:

mm / FRONT
mm / REAR

Shocks:

	FRONT	REAR
OIL		
BRAND		
PISTON		
SPRING		
REBOUND	%	%
STD/EMUL/VENT		
NOTES:		

Tires/Wheels:

	FRONT	REAR
BRAND/TREAD		
COMPOUND		
INSERT		
WHEEL		
NOTES:		

Differential Oil:

	FRONT	CENTER	REAR

Electronics:

ESC:	
BATTERY:	
MOTOR:	
RADIO:	
SERVO:	

Drivetrain:

PINION SIZE		(teeth)
-------------	--	---------

Chassis Braces:

Front Middle Rear

(front brace is always recommended)

Notes:

Name: _____ Date: _____ Event: _____

Track: Indoor Outdoor Size: Small Medium Large Traction: Low Med High

Surface: Smooth Bumpy Rutted Type: Loose/Loamy Hard Pack Blue Groove Clay

Bumpsteer/Ackerman/Servo Saver/Steering Stop: _____ Condition: Dusty Dry Wet Muddy

Washers over # washers under #

ballstud orientation

ballstud orientation

front middle rear

Front End:

OFFSET: 0mm, 1mm, 2mm

"A" Block

(Sweep) (0° WITH CENTER DOT INSERT)

"B" Block

(Kick Up) (10° WITH CENTER DOT INSERT)

Rear End:

OFFSET: 0mm, 1mm, 2mm

"C" Block

(Anti-Squat) (2° WITH CENTER DOT INSERT)

"D" Block

(Rear Toe) (3° WITH CENTER DOT INSERT)

0° (OFFSET) 5° 1° 5° 1° 1° 5° 5° 1°

Turns from fully tight # of washers

Suspension:

	FRONT	REAR
RIDE HEIGHT		
CAMBER		
CASTER		
SWEEP		
KICK UP		
ANTI-SQUAT		
TOE (in/out)		
SWAY BAR		
SHOCK LENGTH (DROOP)		

Body/Wing:

BODY MAKE	
WING MAKE	

POSITION SETTINGS

1 - REARWARD LOW 2 - FOREWARD LOW
3 - REARWARD HIGH 4 - FOREWARD HIGH

DOWNFORCE SETTINGS

(downforce angles)

Wheelbase:

mm / FRONT
mm / REAR

Shocks:

	FRONT	REAR
OIL		
BRAND		
PISTON		
SPRING		
REBOUND	%	%
STD/EMUL/VENT		
NOTES:		

Tires/Wheels:

	FRONT	REAR
BRAND/TREAD		
COMPOUND		
INSERT		
WHEEL		
NOTES:		

Differential Oil:

	FRONT	CENTER	REAR

Electronics:

ESC:	
BATTERY:	
MOTOR:	
RADIO:	
SERVO:	

Drivetrain:

PINION SIZE		(teeth)
-------------	--	---------

Chassis Braces:

Front Middle Rear

(front brace is always recommended)

Notes:



Tekno RC
10755 Scripps Poway Pkwy #598
San Diego CA 92131
USA

www.teknorc.com

