

TKR5206X

MECHANICAL BRAKES

A mechanical brake setup will allow you to adjust the front/rear brake bias as well as reduce the running temperature of your motor and ESC. Mechanical brakes can provide an advantage on tracks where traction is scarce, but it may suit your driving style in any case. These instructions assume that the center differential/motor mount is completed but not yet installed on your EB48 (Step L). If your vehicle is complete, you will need to remove the center differential/motor mount to complete the brake installation. Refer to Step L in the EB48 instruction manual if you need help.

STEP 1

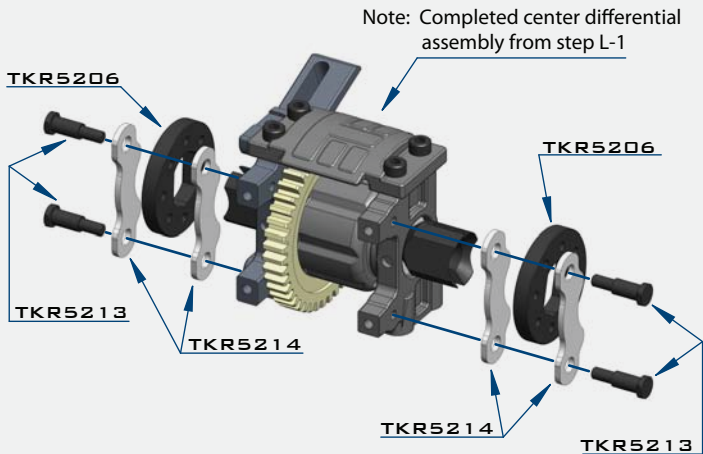

STEP 2

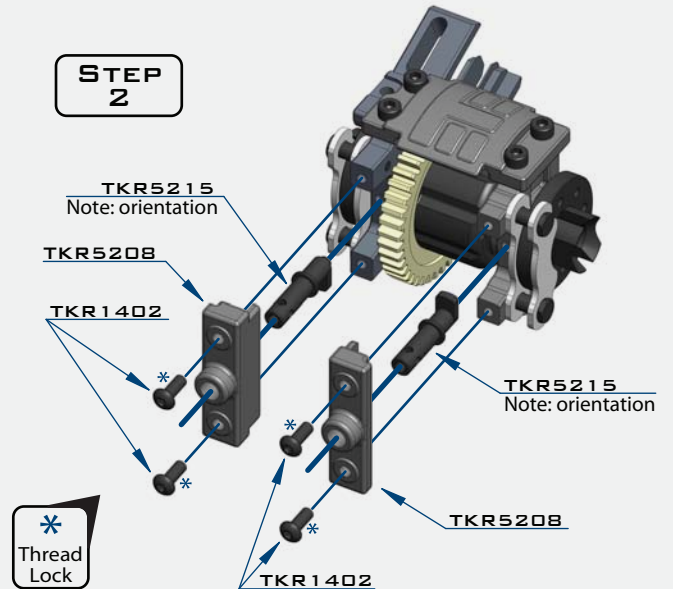

STEP 3

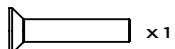
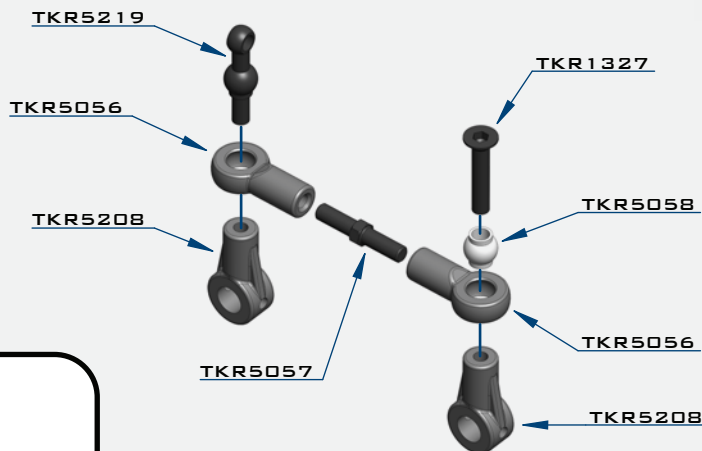

TKR1327
M3X16MM FLAT HEAD SCREW



TKR1402
M3X8MM BUTTON HEAD SCREW



TKR1601
M3X4MM SET SCREW



TKR5058
PIVOT BALL M3X5.8MM
NO FLANGE

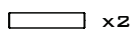

TKR5208
CAM JOINT PIN

STEP 4

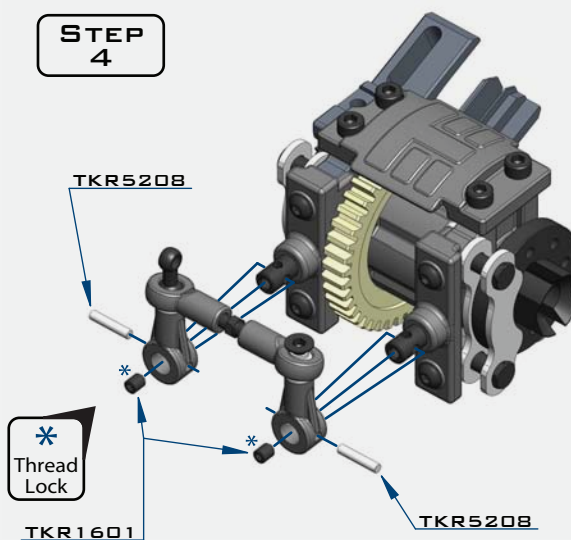

TKR5206X

MECHANICAL BRAKES (CONTINUED)

STEP 5

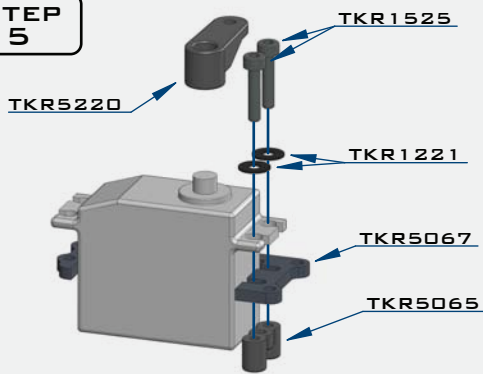

STEP 6

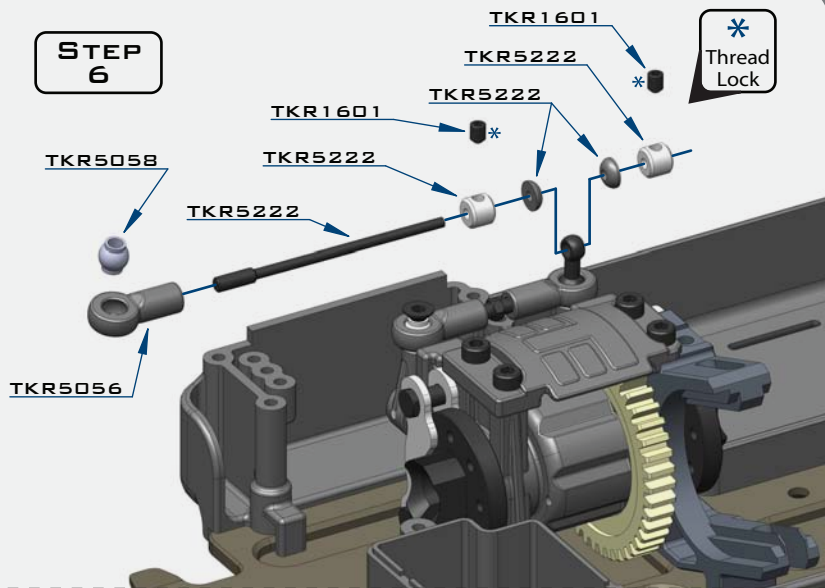

Radio Setup:

- You need a separate servo for the brakes. A servo with at least 160oz/in torque @ .15sec or faster is recommended.
- To set up the brake servo action, you will need a radio transmitter that has the ability to perform 3rd/AUX mixing on the throttle channel.
- Adjust the mixing function so the brake servo only moves when activating the brakes (moving the trigger forward on your transmitter). If the servo is also moving when on throttle, you will damage the brake system or your servo and the car will not function properly.
- Set the ESC brakes to 0 (zero). Although, you can still use the ESC for partial brakes or drag brake if desired.
- Refer to your transmitter manual for mixing functions specific to your brand.

STEP 7

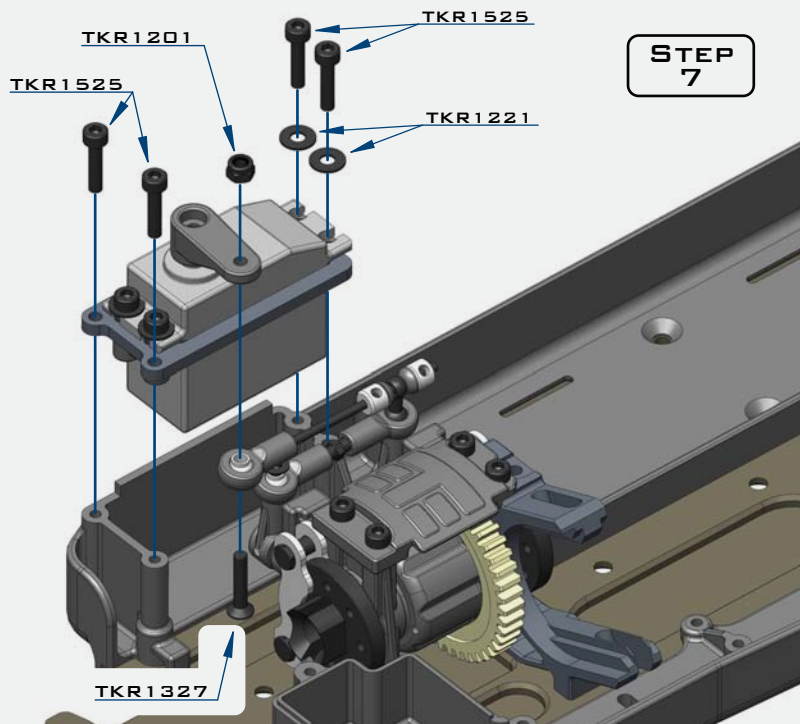

Adjusting the Brakes and Brake Bias:

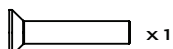

x1
TKR1327
M3x16MM FLAT HEAD SCREW

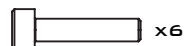

x6
TKR1525
M3x14MM CAP HEAD SCREW



x2
TKR1601
M3x4MM SET SCREW



x1
TKR5058
PIVOT BALL M3x5.8MM
NO FLANGE



x1
TKR1201
M3 LOCKNUT BLACK

• The total braking force is set by your transmitter via servo travel (EPA for 3rd/AUX/Brake channel)

• When your servo is in the neutral position, there should be no contact with the brakes. Use the ESC settings to adjust drag brake.

• Adjust the brake linkage stops (TKR5222) and servo EPA to set the brakes to your liking. Some prefer the brakes to come on very quick, while others prefer them to be a little more progressive.

• The brakes bias is adjusted by lengthening or shortening the brake adjustment turnbuckle (TKR5057). A longer link will provide more rear braking bias, a shorter link will provide more front braking bias.

• We recommend leaving the servo horn loose while adjusting the brake bias. This way you can test the brake bias, take the servo horn off to adjust, test, repeat if necessary. When you have the brake bias where you want it, tighten down the servo horn.

STEP 8

