

Tekno RC Brushless Conversion for REVO/Slayer

Disclaimer:

Please read and follow these instructions carefully to ensure proper installation. Improper installation may result in damage to drivetrain and/or electronic components. Tekno RC is not responsible for any property damage or personal injury encountered during operation.

Thanks:

Congratulations on your purchase of the Tekno RC brushless conversion kit for the Traxxas Revo 2.5/3.3 and also the Slayer line of vehicles. Although this kit was designed around racing and using a forward only configuration, reverse can be retained for ultimate bashing. We strongly suggest a single steering servo setup.

Tools Needed:

- A good set of metric hex wrenches. The stock tools that came with your vehicle will work, but a pro quality set is recommended.
- Flywheel wrench or piston locking tool to remove the flywheel and clutch assembly from the engine.
- A 10mm wrench or socket tool will be needed to remove and install the clutch nut.
- Gloves. Use when removing and installing the flywheel assembly (see below).
- Thread locking compound – **BE SURE TO USE THREAD LOCK ON ALL INDICATED AREAS.**

Before You Begin:

Clean your truck. Working on a clean vehicle will make things go remarkably smoother and make for a much more enjoyable building experience.

Clear an adequate work area. There are several steps and many pieces involved in this upgrade. A clean work area with ample room will help you stay organized and avoid losing parts.

Note on configuration:

- If you want to use reverse with the ESC/Motor, you must lock the transmission into 2nd gear. Search on Google for 'revo lock in 2nd gear' and a tutorial will come up.
- We recommend using a center differential or Forward Only Conversion and a single steering servo along with the supplied Tekno RC RX Box.
- If you want to use both steering servos, you will need to relocate the receiver to the left side radio box cover/area

In addition to carefully following these instructions for the installation of the hardware included with this kit we highly recommend that you thoroughly familiarize yourself with the manufacturer's manuals for the electronic components that you ultimately decide on to complete your conversion. Some of these components, such as the electronic speed controller (ESC) and motor, may require you to solder connectors. If you are not experienced performing this task, your local hobby shop should be able to help you. They may charge a small fee.

Parts that will be re-used: M3 socket head screws used for setting the mesh, clutch shoes and clutch bell (optional).

Items that will not be re-used: engine, exhaust pipe, fuel tank, switch, receiver battery, right side radio box, flywheel.

Motor Prep:

A motor with a **5mm shaft is required** for use with the Tekno RC Brushless Conversion Kit. The maximum diameter you are able to use is **44mm**. The maximum length is **76mm**. Some motors will require the installation and soldering of some kind of connector to attach to the ESC. As of this writing, the following motors have been verified to work with the Tekno RC Brushless Conversion:

- Castle Mamba Monster motors, Tekin T8 motors
- Castle and Tekin clones (Hobbywing, Leopard, etc)
- Neu 15 series (w/ 5mm shaft, up to 1515 length)
- Feigao/Nemesis/Wanderer 540L/XL/XXL series (w/5mm shaft)
- Hacker C-50S/L (w/5mm shaft – the **C50-MAXX is NOT compatible**). The C-50XL will work as well, but you may experience clearance issues with the rear a-arm.

If the motor you decide to use with your conversion does not have a flat area on the shaft, you may need to grind a small flat area on the motor shaft where the set screw comes in contact with it. We recommend a small grinding wheel on a Dremel tool.

Vehicle Prep:

You may use the exploded views of the Chassis Assembly for reference for removal of the following items:

http://www.traxxas.com/products/nitro/revo/revo33/blueprints/060324_Revo33_chassis.pdf

Removal of items:

- Remove fuel tank and fuel tubing
 - Remove rear fuel tank mounting post.
 - Remove EZ-Start wires from the body post and chassis
- You will need to loosen and/or remove the rear shock mount to do this. After the wires are removed from the body post and chassis, tighten the rear shock mount back up.
- Remove Pipe hanger screw.
 - Remove Engine – Please note the following when removing the engine
 - If you are still using the EZ-Start system, unscrew the left side of the roll hoop to make clearance for removal of engine.
 - If you are running a chassis brace (we strongly suggest you do), loosen the front two screws under the vehicle that are screwed into the engine mount.
 - Unscrew and remove the two long M3 socket head screws used for setting the mesh. Set them aside, you will need them to install the Tekno RC brushless motor mount later.
 - Remove left radio box cover to make clearance for engine removal.
 - Unscrew and remove throttle linkage. Remove from throttle servo horn. Remove throttle return spring.
 - Remove engine.
 - Remove switch, Opti-Drive and receiver from right radio box.
 - Disconnect the receiver battery from the receiver.
 - Remove the right radio box.

Step 1 - Elektri-Clutch Assembly (optional):

Remove clutch bell, clutch, flywheel, and collet from engine.

Wear gloves here and use a piston locking tool or flywheel wrench if necessary. If your clutch is worn or old we suggest starting with a new one (stock, MIP, or M2C). You will experience very little clutch wear compared with a nitro engine since the clutch shoes won't 'drag' at idle as they do on a nitro setup. As a reference, our original clutch shoes lasted through all development and testing. You can't beat that!

Locate the Elektri-Clutch adapter. Install the clutch shoes on to the adapter. **We strongly recommend installing them in the leading position (see fig. 1)** for most surfaces and track conditions. For really loose tracks where traction is a problem, try the stock trailing position.

Install clutch bell of your choice. Smaller clutch bell = better acceleration + more run time, larger clutch bell = higher top speed + shorter run time. Secure with M3 x 8mm screw and washer (included). Check to make sure the clutch bell spins freely. You may need to use shims to ensure smooth operation (not included).

Step 2 - Motor Mount Assembly:

Locate the motor mount base (the part with the 'TEKNO' logo – TKR40011X)

Your kit included a 42mm mount (TKR4142X) for use with most popular 1/8th scale motors (Castle, Tekin, etc). Other size mounts are sold separately (TKR4136X, TKR4140, TKR4144X). Slip the motor into the motor mount and secure the motor with the supplied M3x8mm flat head screws. If only 2 of the 4 holes line up, that will be plenty to secure the motor.

Secure the motor mount to the base using M4 x12mm button head screws (see fig. 2/3). **USE thread locking compound on all screws here.**

If you are using the Elektri-clutch, slide it on to the motor shaft. Secure with **one (1)** M4 setscrew. **Use a generous amount of thread locking compound on this connection.** If for any reason the clutch assembly comes loose, reapply thread locking compound and make sure the setscrew is tightened down onto the flat spot of the motor shaft (see motor prep).

If you are using standard pinion, just install it as you would in any other application and tighten down the set screw.

The motor assembly is now complete and ready to be installed onto the vehicle. It is installed exactly the same way as the nitro motor mount except you don't need to use the small star washers that go in between the two parts of the mount. Our testing showed these washers were not needed. Use the two long screws you removed earlier and adjust the mesh exactly as before. Tighten as you would with the nitro mount. If for any reason the screw holes strip, you could find a longer screw (say M3x35mm socket screw) and place a locknut on the end of it to be able to tighten it down. Alternatively, you could get a replacement motor mount (TRA5360).

Step 3 - Battery Tray:

Locate the battery tray and the supplied Tekno RC battery straps. The straps must be installed before securing the battery tray to the chassis. Install the straps but don't pull them tight yet. Taking one of the shorter straps, insert it into the tray in a weaving pattern as shown (see fig. 4A). Repeat for the other short strap. The longer strap goes lengthwise and is installed in the same manner as the shorter straps. For the long strap, it doesn't matter which end has the fastening ring, but the hook area orientation is. As a reference, the hook sides should all be facing to the outside of the battery tray and the Tekno RC logos should all be facing toward the inside of the tray. The straps should be loosely installed in the battery tray at this point.

Next, position the battery tray on the chassis (see fig. 4B). Working around the loose battery straps insert the supplied fasteners through the battery tray and the chassis in the order

shown in the diagram (fig. 4B):

- Insert the supplied M4 x 10mm button head screw into the middle hole of the battery tray and through the chassis.
- Insert the supplied M4 x 16mm button head screw at the front of the tray.
- Insert the supplied M3 x 16mm button head screw and M3 washer at the rear of the tray.
- Secure all screws with the supplied locknuts.

Once the battery tray has been secured to the chassis the battery straps can be pulled tight.

The battery tray has been designed to accommodate 2 standard stick packs, A123 cells arranged in a 2x2x2 configuration, and a variety of lithium polymer batteries up to 50mm in width, and 148mm in length. There are no restrictions on height, but the straps may not be able to accommodate very large batteries. For optimum weight balance, you'll want to use batteries with a total weight below 600 grams. For shorter or smaller batteries, we recommend using a piece of foam or other material to help keep the battery from moving around.

Step 4 - ESC Mount:

Locate the ESC mounting bracket and tray (TKR40014 and TKR40015). Use the supplied M3 x 10mm countersunk screws to secure the tray to the bracket. **USE threadlock on these 2 screws. (see fig. 5)**

Unscrew and remove the top two screws from the transmission case.

Using the supplied M3 x 15mm countersunk screws, install the ESC tray to the top two holes of the transmission case. To adjust the transmission shifting point, remove the left screw (the one not covered by the ESC tray) and simply rotate the ESC tray up to expose the shift point access hole. There are some 2-sided tape squares to use for securing the ESC to the tray. There are also little grooves cut into the tray to better hold zip ties if you need to zip tie the ESC down for more security.

Step 5 - Receiver Box:

The battery tray must be installed prior to installing the receiver box (see Step 3). Please see end of instructions for mounting the Tekno RC Receiver Box.

Step 6 – Reinstall Electronics:

Specific instructions to cover all cases is beyond the scope of these instructions. There are many ways to wire all of the electronics. Since there are so many variables, again, we won't be able to provide any specifics as to how to wire and setup your electronics. A basic understanding of RC radio systems, electronic speed controls and batteries is assumed here. Please refer to your component's user manuals for wiring diagrams and suggestions. Using an external BEC, cooling fans, or personal transponders may require more soldering and/or the use of 'Y' connectors to get power to the various accessories. Also, if you are using a 2 channel radio, you will need to split the brake servo and ESC signal with a Y connector. If the brake servo is reversed, you will need to adjust your linkage to operate the other way since you don't want to reverse the throttle/ESC channel.

Step 7 – Prepare for Take Off:

Congratulations. Your assembly is complete and you are almost ready to drive your new electric Traxxas Revo. Before you do we recommend you go through one last setup check.

- Refer to your ESC manual and double check all wiring

connections

- Be sure you have followed all battery charging guidelines and that your battery is charged and ready to go.
- Before connecting your battery for the first time we recommend you disconnect the motor wires from the ESC and check your steering and braking endpoints and trims.
- Place your truck on a stand so that the wheels are off the ground and reconnect the motor wires. Gently test the throttle to ensure the motor spins in the correct direction (counterclockwise). Generally, if the clutch engages but the wheels do not spin, switch any of the two motor wires to reverse the rotation of the motor.
- If everything checks out. Place the vehicle on the ground and enjoy!
- Support your local track and get out there and race your new electric MT – you'll be surprised at the results.

FIG. 1 - ELEKTRI-CLUTCH ASSEMBLY

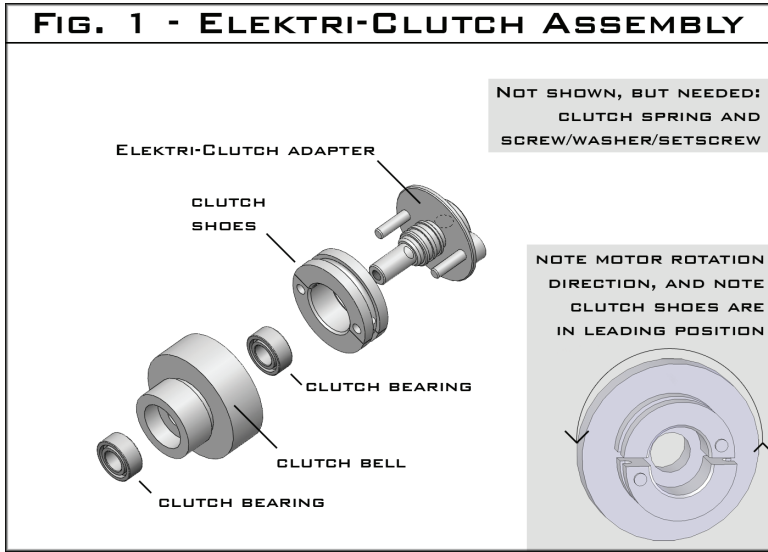

FIG. 2/3

(REPLACES FIG.2 AND 3 IN ORIGINAL INSTRUCTIONS)

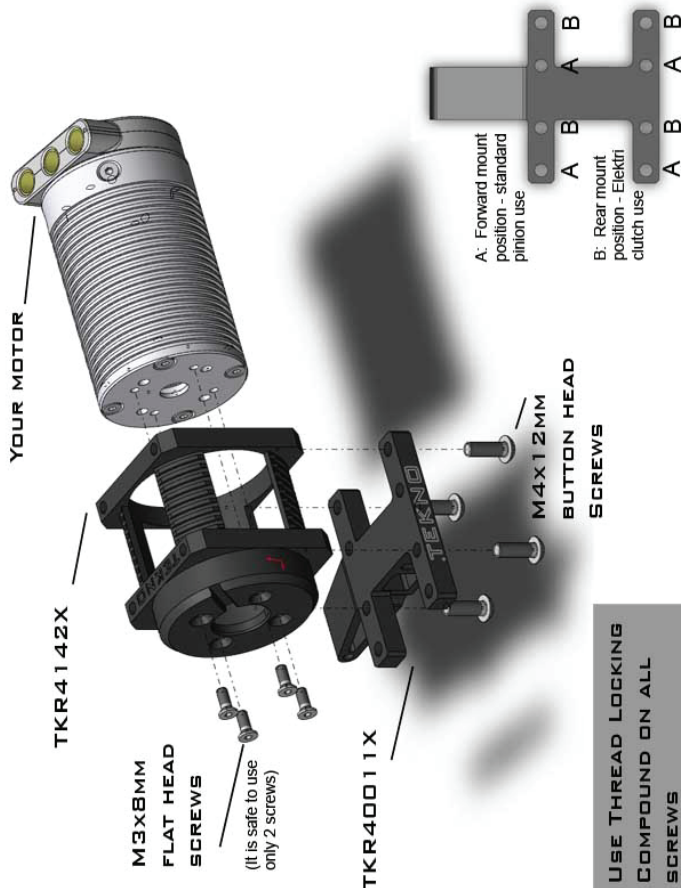

FIG. 4A - BATTERY STRAP INSTALLATION

1. FIT STRAPS LOOSELY
2. POSITION ON CHASSIS
3. PROCEED TO FIG. 4B

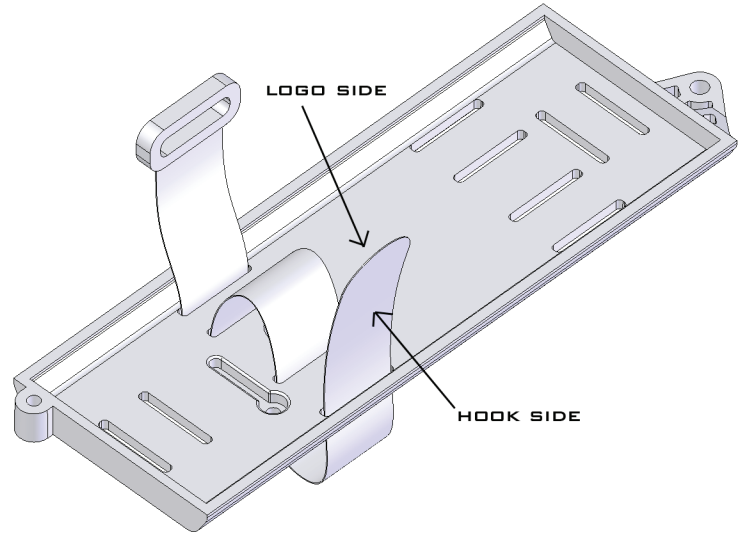

FIG. 4B - BATTERY TRAY INSTALLATION

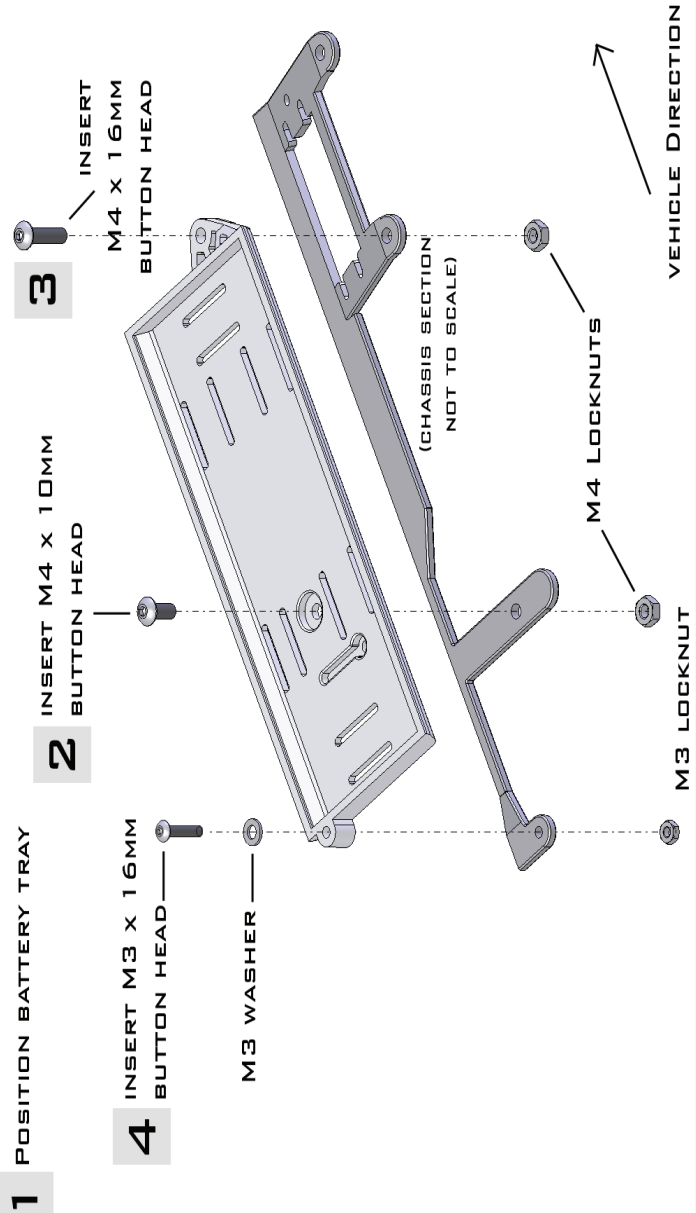
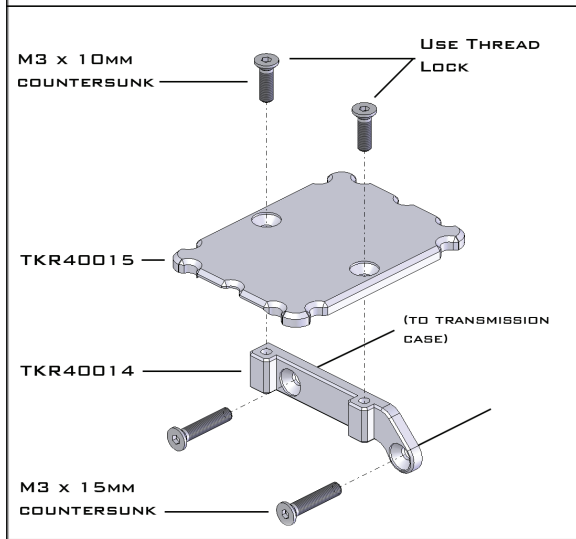

FIG. 5 - ESC TRAY ASSEMBLY



Tekno RC RX Box for REVO

What you'll need for installation:

- * A single steering servo setup, mounted on left side, or the Tekno RC Battery Box installed.
- * The tools that came with your REVO (or equivalent).

1. Mount RX box bottom - Using the supplied M3x10mm buttonhead screws, mount the RX box bottom to the chassis where the right side steering servo used to be, as shown below.

2. Install antenna tube and receiver - Thread your receiver's antenna through the antenna tube. Insert the antenna tube into the integrated antenna tube mount as shown below.

The white double sided tape is used to fasten the receiver to the bottom of the RX box. Peel off one side and apply it to the bottom of your receiver.

Pull the antenna through the tube until the receiver sits inside the RX box (about 3/4" of antenna between the receiver and the tube). Once you have the receiver where you want it, twist it up slightly and pull off the other side of the mounting tape, exposing the adhesive. Carefully press the receiver back down, fastening it to the RX box.

3. Mount the receiver switch, plug in electronics - There is a cutout in the RX box top to mount the stock switch harness (most standard switch harnesses will also fit). Using a couple 2x8mm screws (not supplied) mount the switch to the RX box top.

Next, plug your servo, battery and switch harness leads into the receiver. Make sure you plug them in correctly. Some people like to use a couple small zip ties to tidy up the servo leads. **For easier battery charging**, you may want to route the red charging lead out one of the holes in the RX box top.

4. Secure RX box top - Before securing the RX box top, check to make sure your radio and servos are functioning properly. If everything checks out, secure the RX box top with the supplied M3x6mm screws as shown in the diagram (Fig. 6, right). Doublecheck to make sure the box top is seated correctly and that all of your servo leads are routed properly and aren't being pinched by the RX box top.

5. All Done - If you need any assistance, please drop us a line at teknorc@teknorc.com. Thanks for your support!

