

Name: \_\_\_\_\_ Date: \_\_\_\_\_ Event: \_\_\_\_\_

Track: INDOOR  OUTDOOR  Size: SMALL  MEDIUM  LARGE  Traction: LOW  MEDIUM  HIGH

Surface: SMOOTH  BUMPY  RUTTED  Type: LOOSE / LOAMY  HARD PACKED  BLUE GROOVE  CLAY  ASTRO

Steering Stop/Arm Settings/Ackerman: \_\_\_\_\_ Condition: DUSTY  DRY  WET  MUDDY

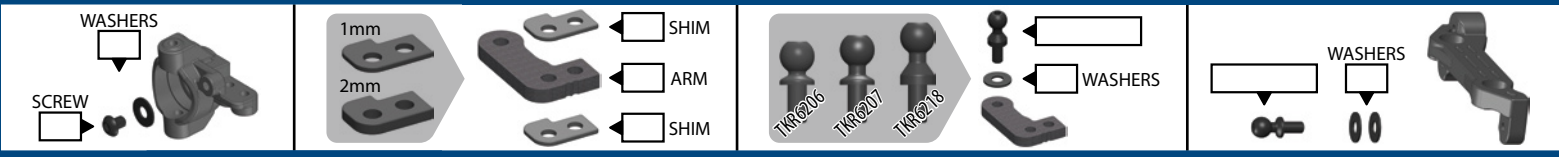

## Front End:

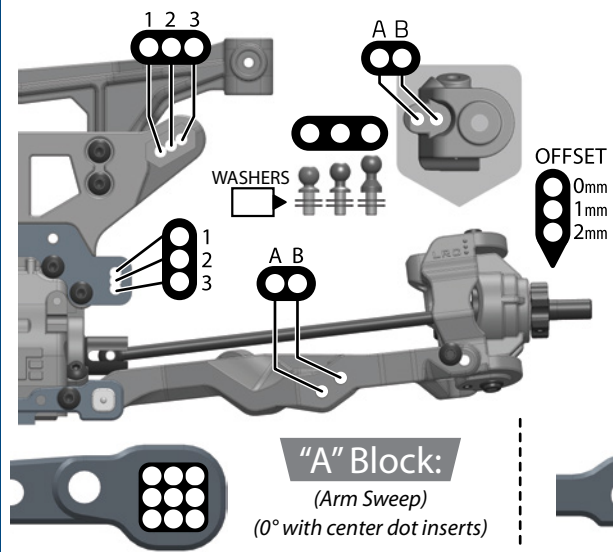

## Suspension:

RIDE HEIGHT:	CAMBER:
CASTER:	SWEEP:
KICK UP:	TOE:
SWAY BAR:	DROOP:

## Shocks:

OIL:	BRAND:
PISTON:	SPRING:
REBOUND:	BUILD:

## Differential Oil:

FRONT	CENTER	REAR
/	/	/

## Drivetrain:

PINION / SPUR: \_\_\_\_\_ / \_\_\_\_\_ (teeth)

## Equipment:

MOTOR: \_\_\_\_\_  
 ESC: \_\_\_\_\_  
 BATTERY: \_\_\_\_\_  
 RADIO: \_\_\_\_\_  
 SERVO: \_\_\_\_\_

## Chassis Braces:

REAR-SHORT:  REAR-LONG:

## Tires / Wheels:

BRAND / TREAD: \_\_\_\_\_  
 COMPOUND: \_\_\_\_\_  
 INSERT: \_\_\_\_\_  
 WHEEL: \_\_\_\_\_  
 NOTES: \_\_\_\_\_

## Rear End:

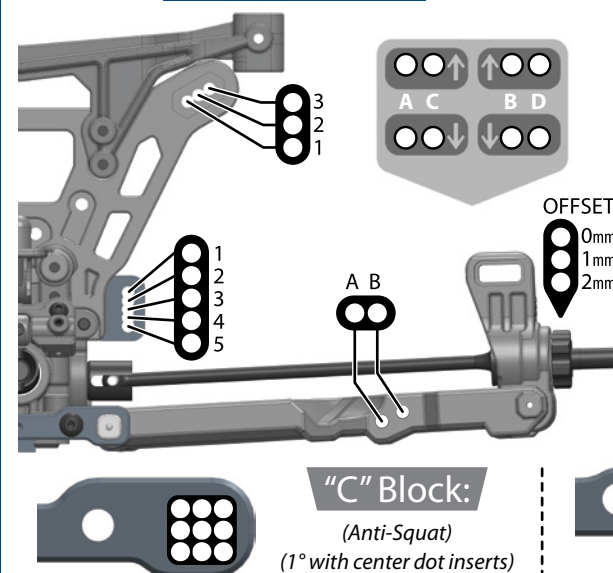

## Suspension:

RIDE HEIGHT:	CAMBER:
ANTI-SQUAT:	TOE:
SWAY BAR:	DROOP:

## Shocks:

OIL:	BRAND:
PISTON:	SPRING:
REBOUND:	BUILD:

## Body

BODY MAKE: \_\_\_\_\_

## Notes:

## Rear Hub:

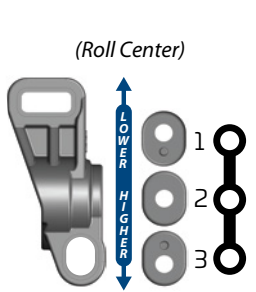

## Wheelbase:

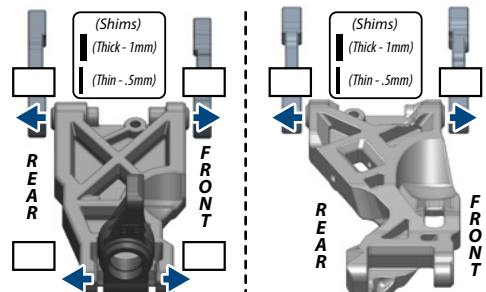

## Body Mounts:

