



EB48 2.0

BUILDING
INSTRUCTIONS

Introduction



EB48 2.0

Thank you for purchasing the Tekno RC EB48 2.0 1/8th 4WD competition electric buggy kit. We are always working on new projects, so please check our website regularly at www.teknorc.com or visit us on Facebook at www.facebook.com/teknorc for all the latest news, parts, and kits.

Take your time! When you work your way through these building instructions, keep an eye out for the following important indicators below:

- **RED TEXT** - *This indicates important areas of the build process that should be observed.*



Thread Lock icons

Thread lock is always used when a screw is inserted into any metal part. (Included with kit)



Grease icons

Grease is usually used on areas with movement and for sealing. (Included with kit)

- **YOUTUBE** - *We also have many useful build videos on Youtube, so be sure to check these out!*
<https://www.youtube.com/c/teknorc>

Additional equipment and parts needed:

- Paint for body
- 1/8th scale ESC and motor system
- High torque steering servo (at least 300 oz/in)
- 4s (4 cell, 14.8v) LiPo battery (at least 5000mAh)
- 1/8th scale tires, wheels & CA glue (or premounts)
- MOD1 Pinion 15 tooth - 25 tooth (TKR4175 - TKR4185)

Tools needed:

- Hex drivers 1.5mm, 2.0mm, 2.5mm
- Nut drivers 5.0mm (TKR1107), 5.5mm (TKR1108), 7.0mm (TKR1109)
- Hobby knife
- Needle-nose pliers
- Shock tool (TKR1115) OR adjustable (Crescent) wrench (for shock assembly)
- 17mm Wheel Wrench (TKR1116)
- 4mm turnbuckle wrench (TKR1103) - 5.5/7.0 two sided wrench (TKR1119)

Disclaimer: Tekno RC is not responsible or liable for any property or personal damage, loss, or injury incurred as a result of using this product. This kit is meant for use by persons 14 years of age or older and in the strict confines of a legally permitted RC track or facility.

Warnings: Always double-check that your radio gear is working properly before operating vehicle. Never operate the vehicle indoors (unless the RC track is an indoor facility). Use caution while operating vehicle so as not to collide with people who may be turn marshalling or who might otherwise not be aware that a fast moving RC vehicle is in the vicinity.

Warranty: We warrant that the parts included in this kit are free from defects. If you find a defective part in your kit, please contact us at info@teknorc.com and we will help to resolve the issue. If you modify any part prior to contacting us, the warranty claim will be void. We do not warranty parts that may be broken during operation of the vehicle or otherwise. Refer to the end of this instruction manual for a listing of spare/replacement and option parts. All spare parts and other info are available on our website (www.teknorc.com) and through our network of domestic and international dealers and distributors.

Bag A

Center Differential

(overview)

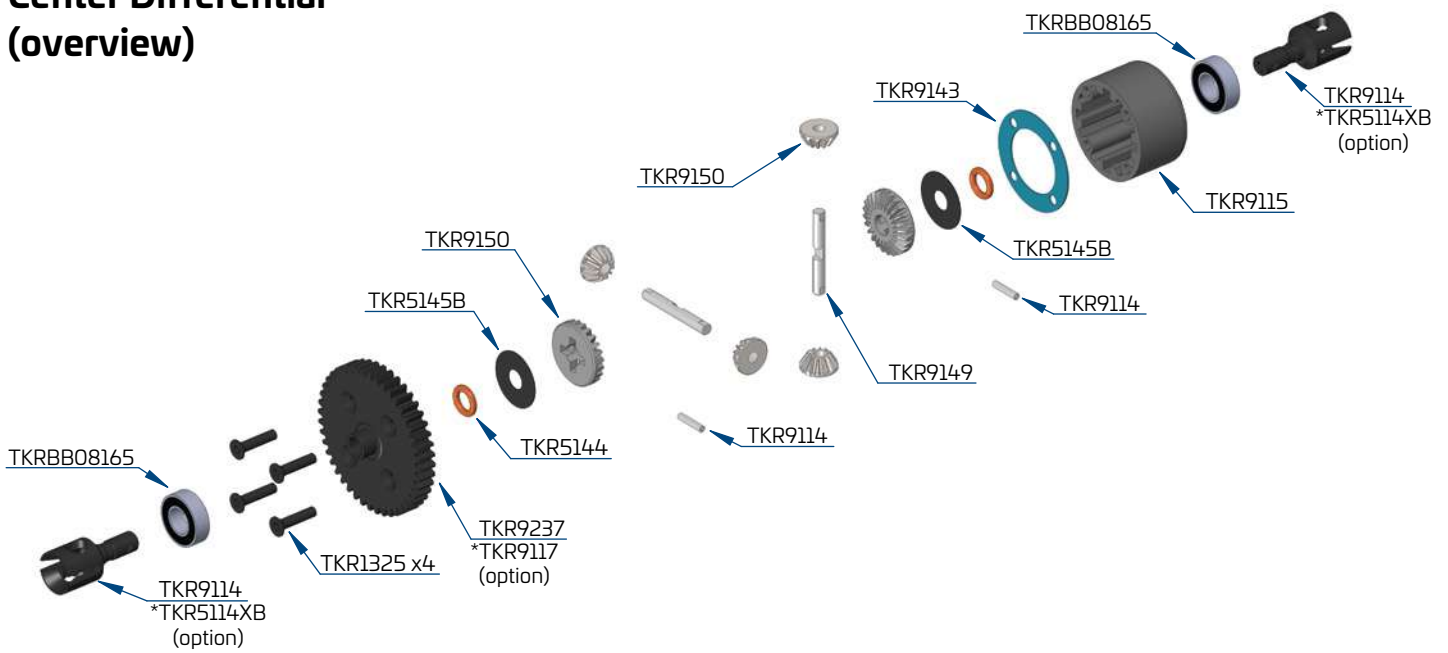

Step A-1

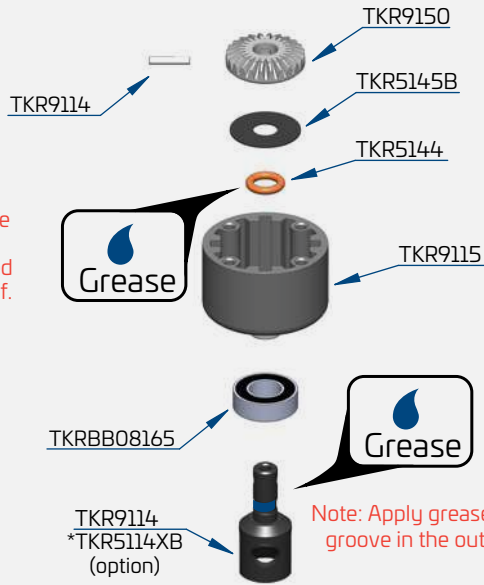

Note: Apply grease to the recess inside TKR9115, where the o-ring is placed as well as the o-ring itself.

Note: Apply grease to the groove in the outdrive.

Step A-2

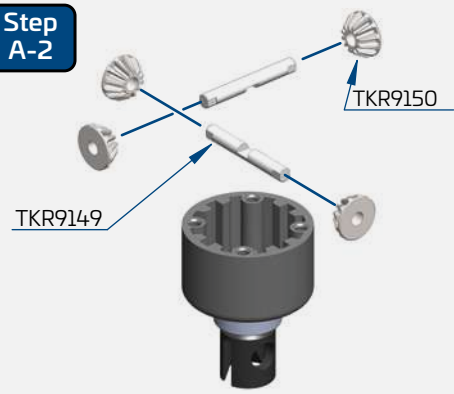

Step A-4

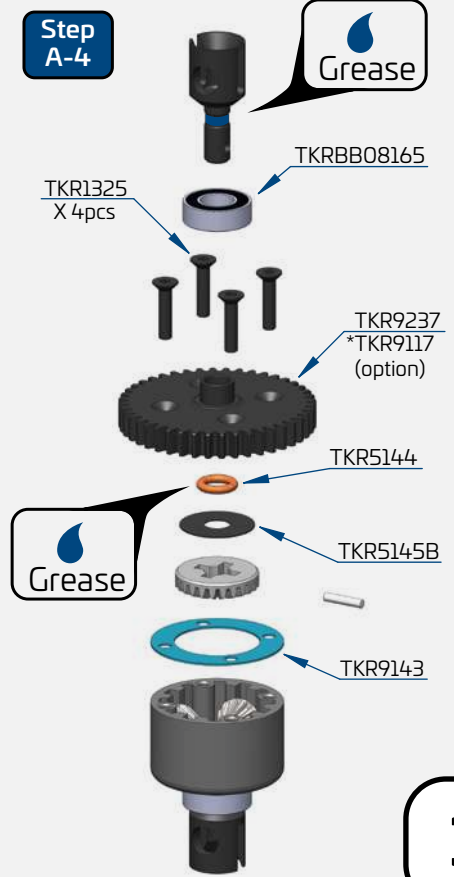

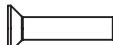
 x4
TKR1325
M3x14mm Flat Head Screw

 x2
TKR5144
Differential O-rings

 x2
TKR5145B
Differential Shims (6x17mm)

 x2
TKRBB08165
Ball Bearing (8x16x5)

Step A-3

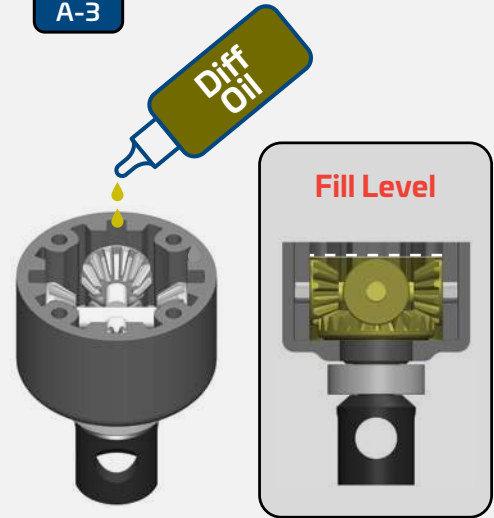

Fill with #10,000 CST oil to 1mm below full
DO NOT OVER FILL

Bag B

Front and Rear Differential (overview)

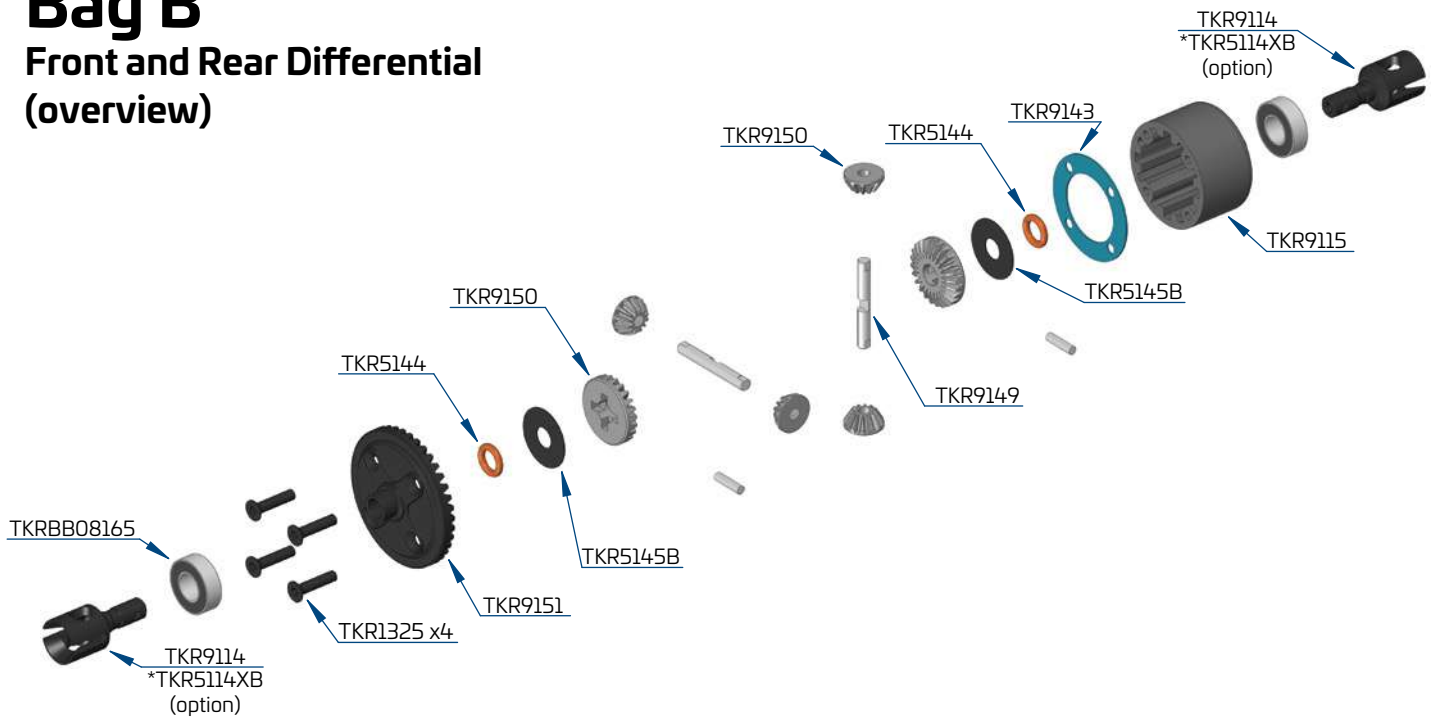

Step B-1

Repeat for rear diff

Note: Apply grease to the recess inside TKR9115, where the o-ring is placed as well as the o-ring itself.

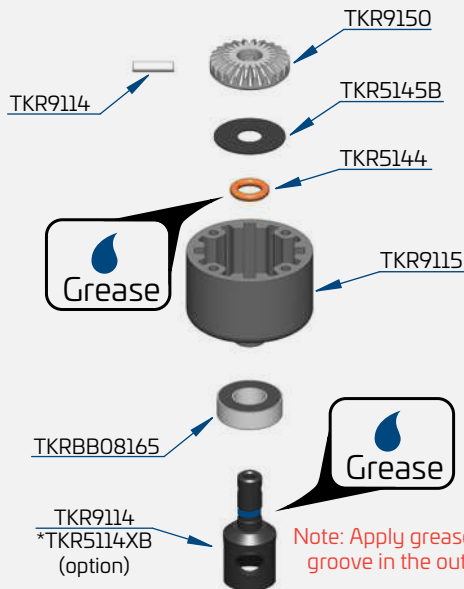

Step B-2

Repeat for rear diff

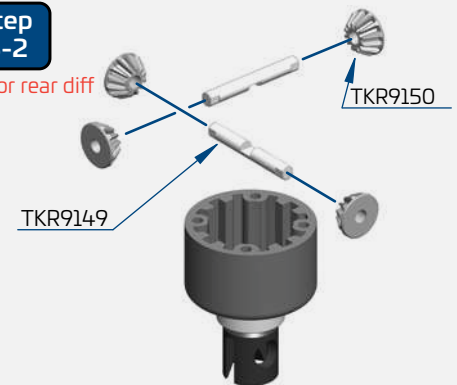

Step B-4

Repeat for rear diff

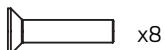
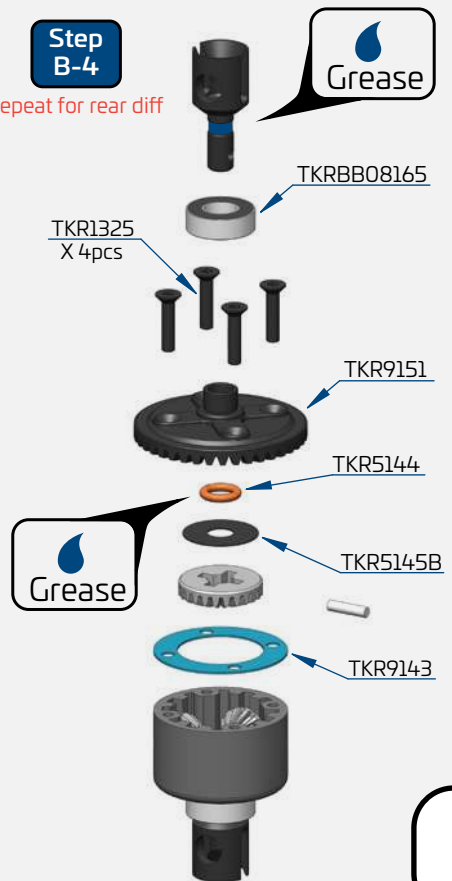

x8
TKR1325
M3x14mm Flat Head Screw



x4
TKR5144
Differential O-rings



x4
TKR5145B
Differential Shims (6x17mm)



x4
TKRBB08165
Ball Bearing (8x16x5)

Step B-3

Repeat for rear diff

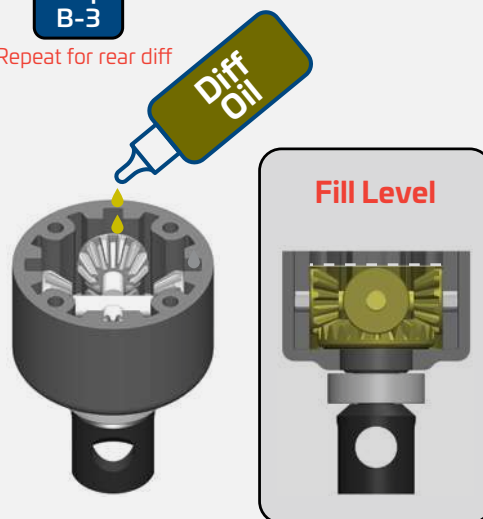

Fill with #10,000 CST oil FRONT
Fill with #7,000 CST oil REAR
to 1mm below full
DO NOT OVER FILL

Bag C Front Gearbox (overview)

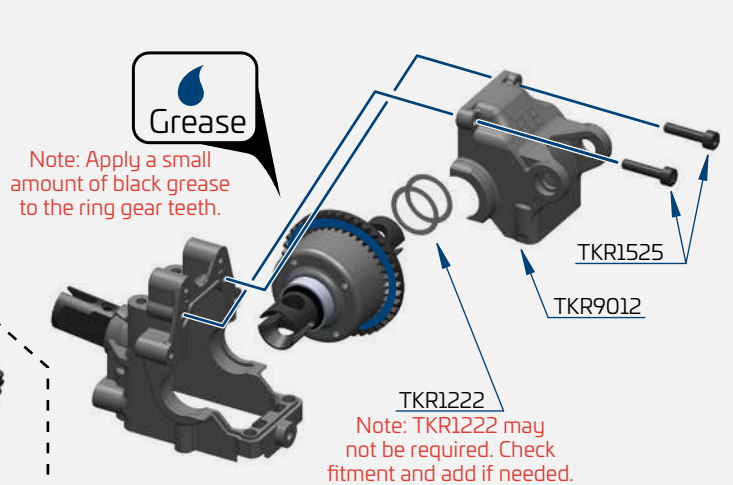
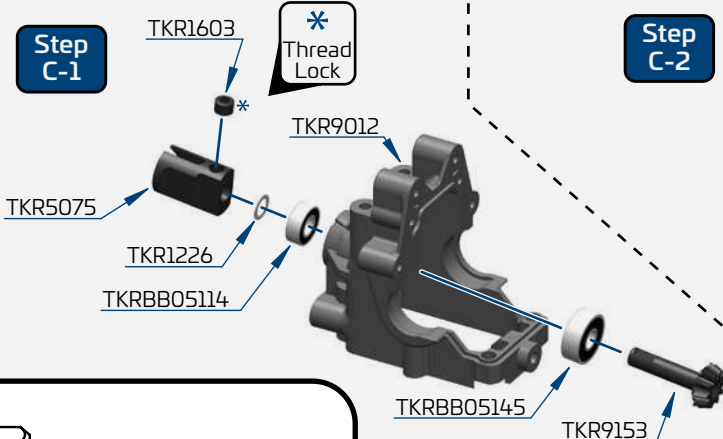
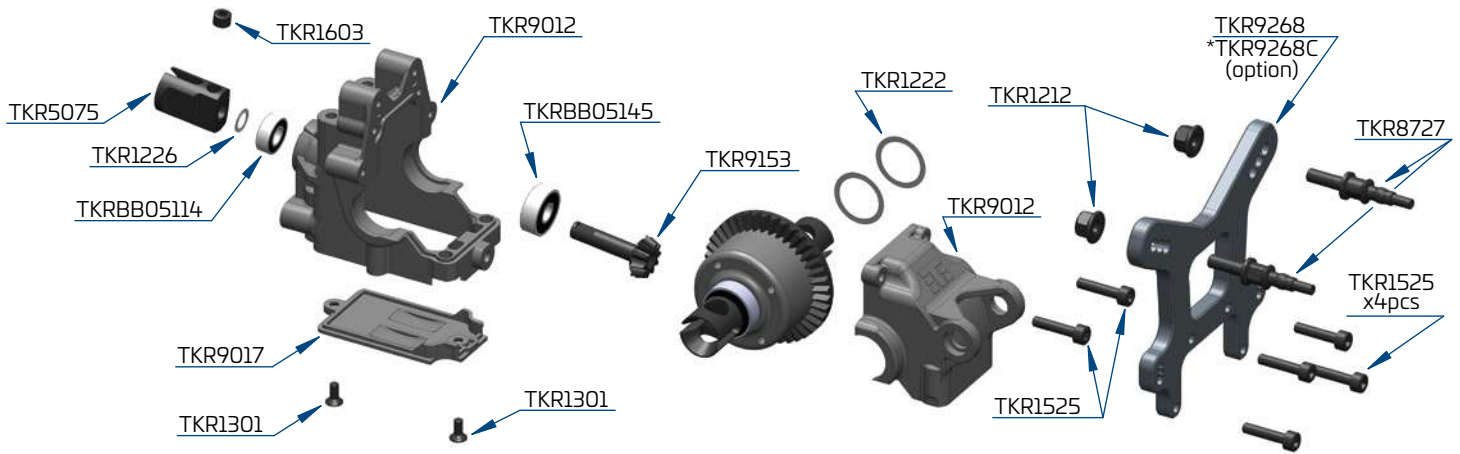

-  x2
TKR1212
M4 Lock Nut Flange
-  x1
TKR1226
M5x7x.2mm Shim
-  x2
TKR1222
13x16x.1mm Shim
-  x2
TKR1301
M2.5x6mm Flat Head Screw
-  x6
TKR1525
M3x14mm Cap Head Screw
-  x1
TKR1603
M5x4mm Set Screw
-  x1
TKRBB05114
Ball Bearing (5x11x4)
-  x1
TKRBB05145
Ball Bearing (5x14x5)

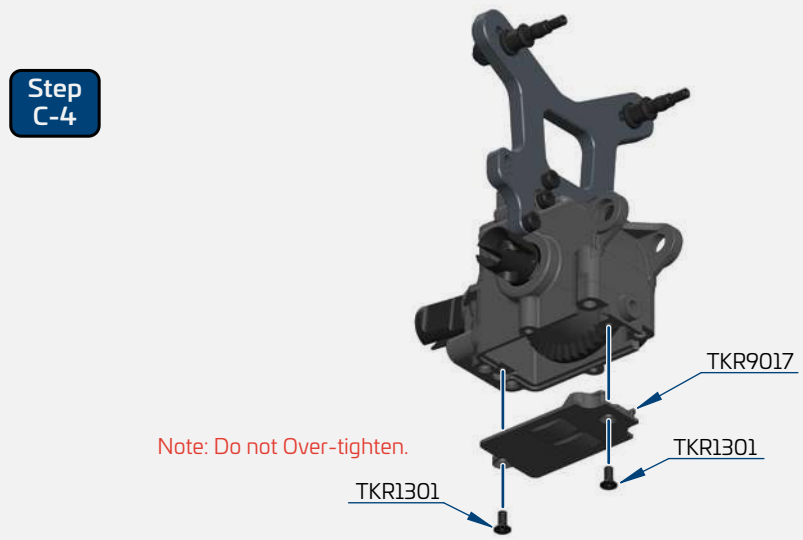
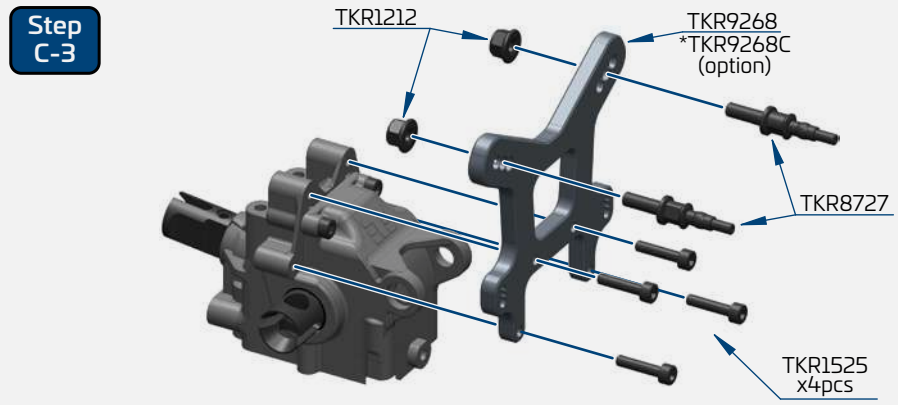

Bag D Rear Gearbox (overview)

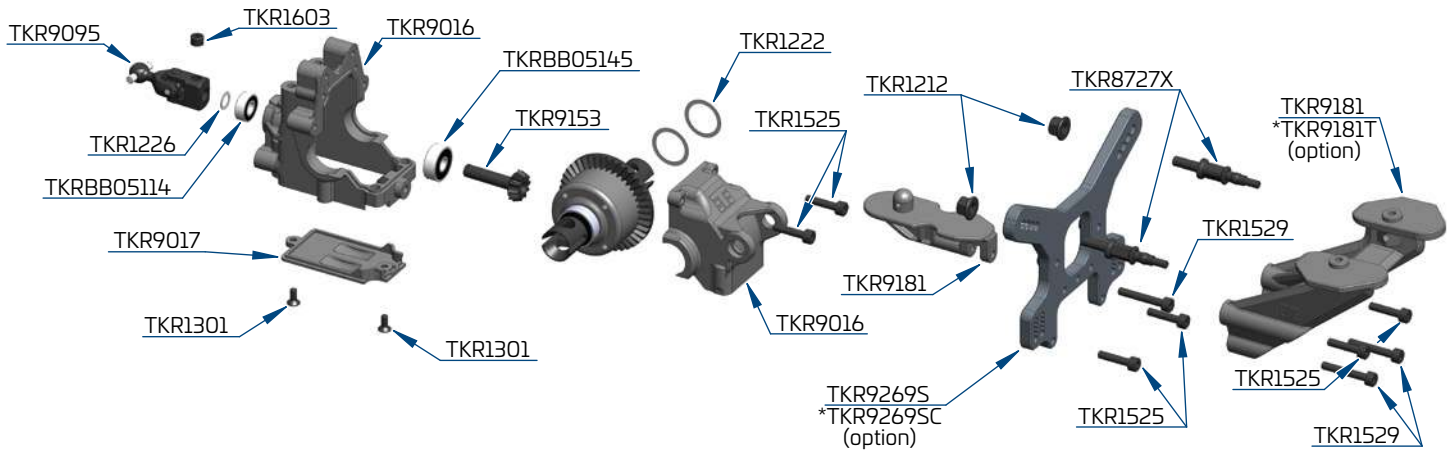

Step D-1

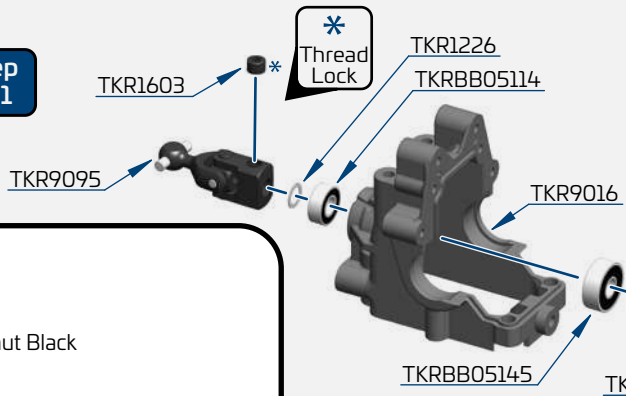

Step D-2

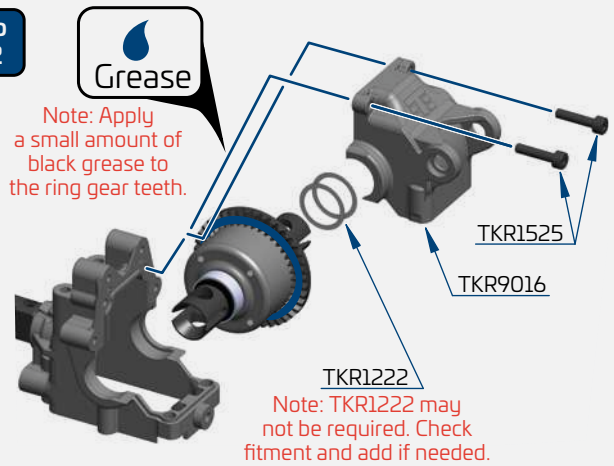

x2
TKR1201
M3 Locknut Black

x2
TKR1212
M4 Lock Nut Flange

x2
TKR1222
13x16x.1mm Shim

x1
TKR1226
M5x7x.2mm Shim

x2
TKR1301
M2.5x6mm Flat Head Screw

x6
TKR1525
M3x14mm Cap Head Screw

x3
TKR1529
M3x20mm Cap Head Screw

x1
TKR1603
M5x4mm Set Screw

x1
TKRBB05114
Ball Bearing (5x11x4)

x1
TKRBB05145
Ball Bearing (5x14x5)

Step D-3

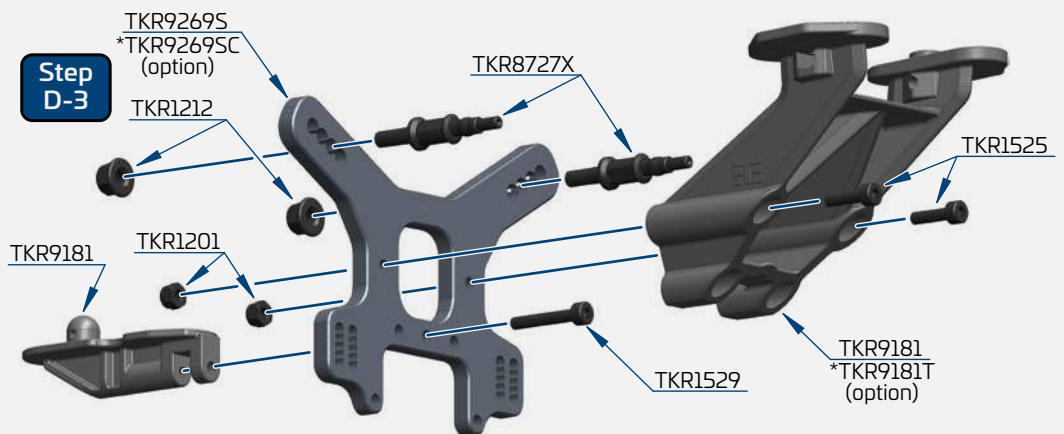

Step D-4

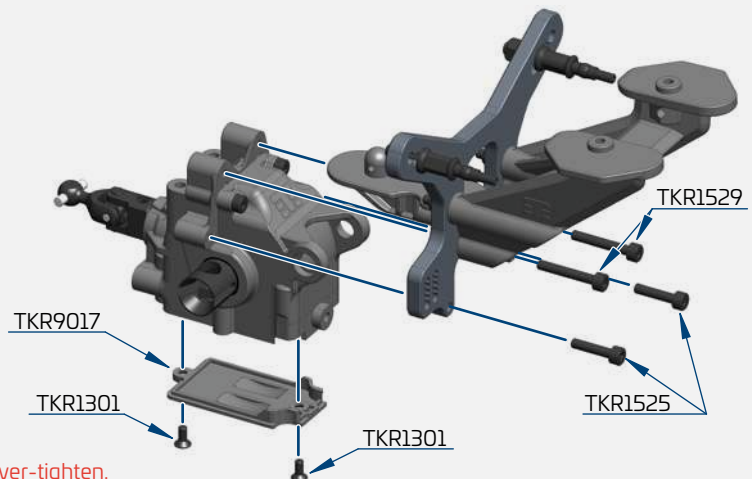

Note: Do not Over-tighten.

Bag E Rear End Assembly

Optional Sway Bars
(sold separately)
 *TKR9190 - 2.2mm
 *TKR9192 - 2.3mm
 *TKR9193 - 2.4mm
 *TKR9195 - 2.6mm
 *TKR9196 - 2.7mm
 *TKR9197 - 2.8mm
 *TKR9198 - 2.9mm
 *TKR9199 - 3.0mm

Step E-1

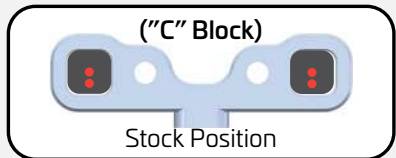
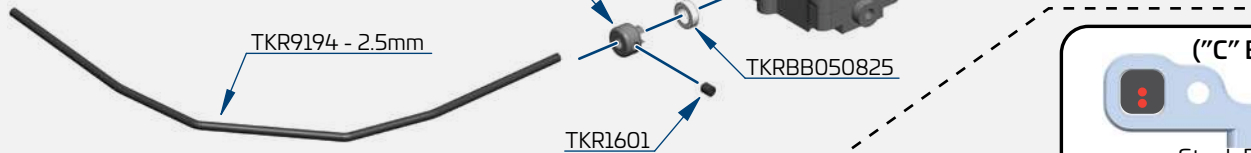

Note: With double dot down inserts, Anti-Squat = 1.5°

Step E-2

* Thread Lock

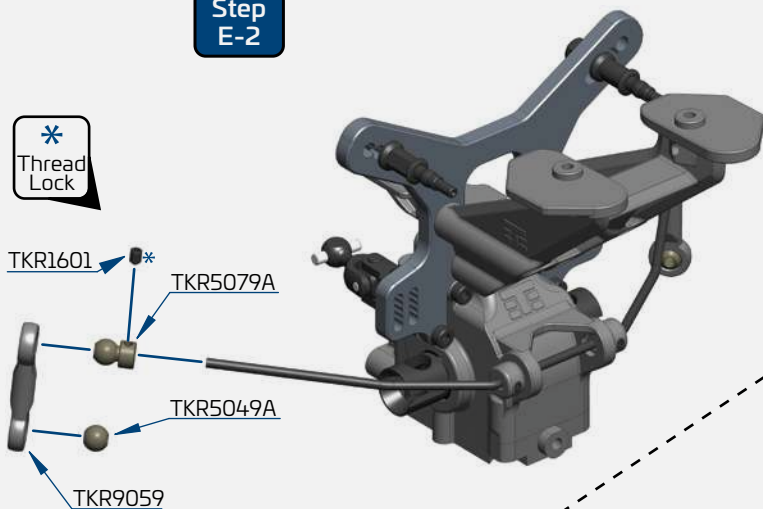

Step E-3

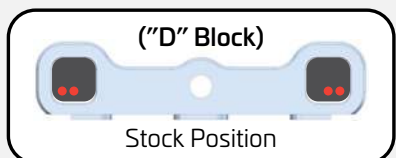
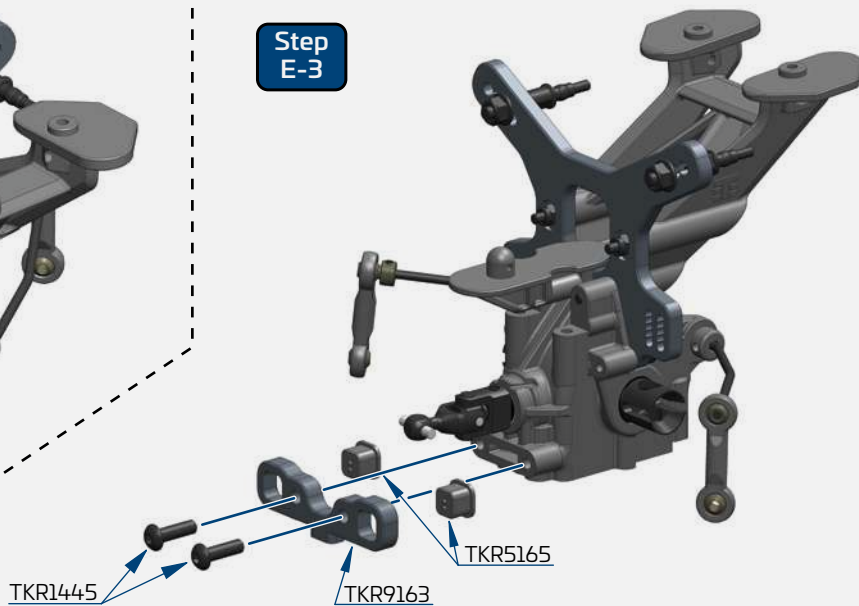

Note: With double dot down out inserts, Rear Toe = 3.0°

Step E-4

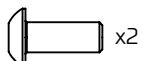
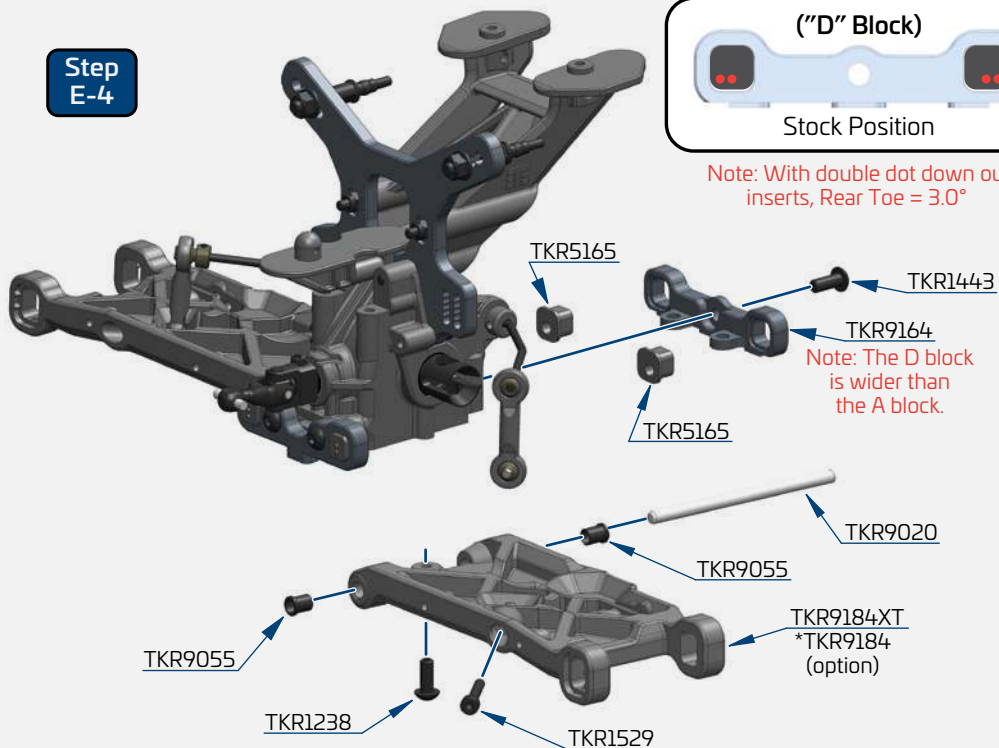

x2
TKR1238
M4x10mm Droop Screw

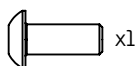

x1
TKR1443
M4x10mm Button Head Screw

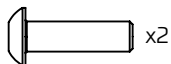

x2
TKR1445
M4x14mm Button Head Screw

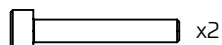

x2
TKR1529
M3x20mm Cap Head Screw

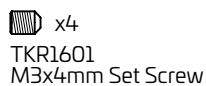

x4
TKR1601
M3x4mm Set Screw



x2
TKRBB050825
Ball Bearing (5x8x2.5)



Bag F

Rear Hub/Camber Link

Step
F-1

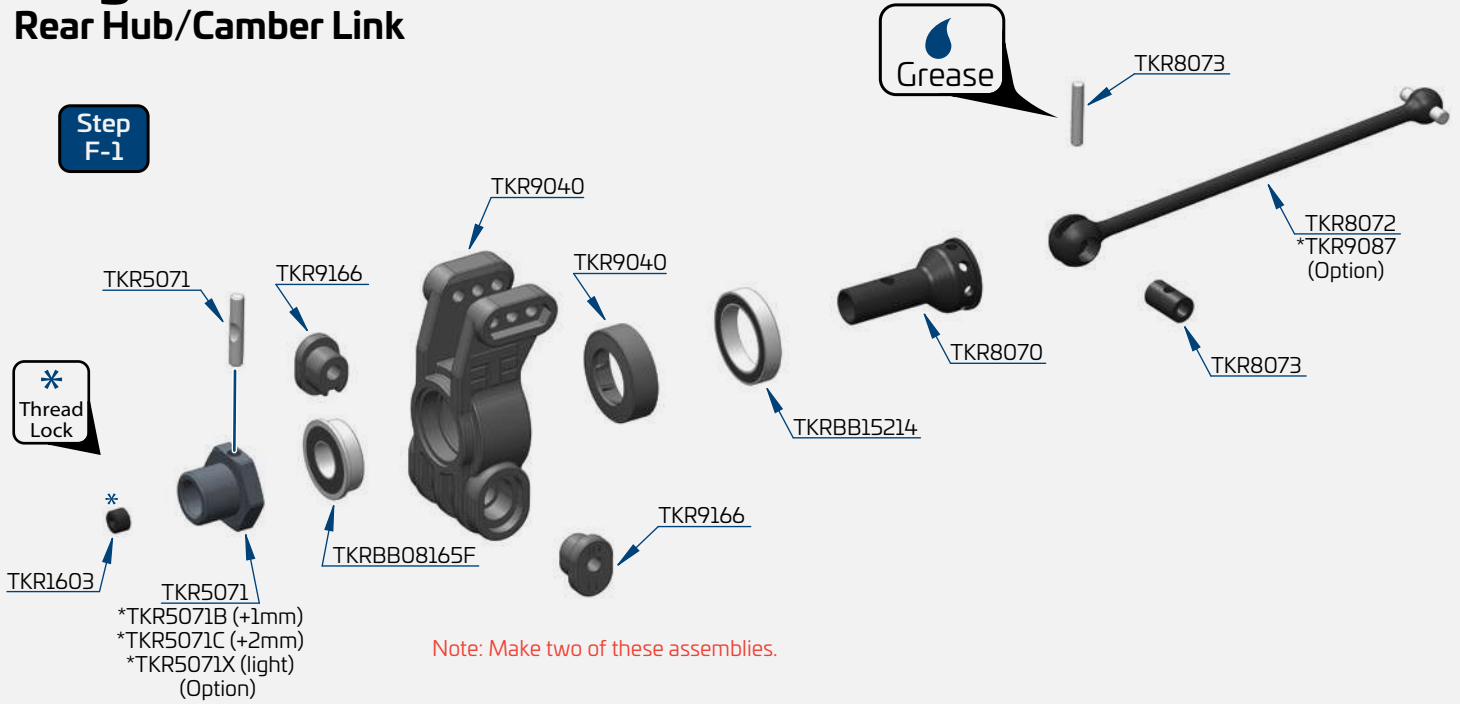

HUB INSERTS

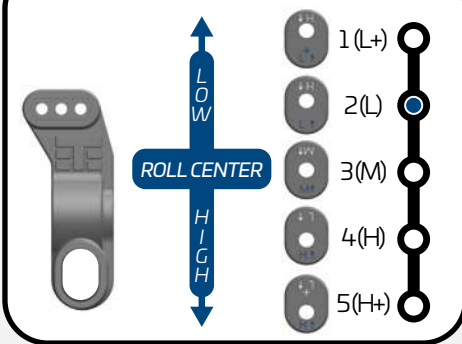

ARM INSERTS

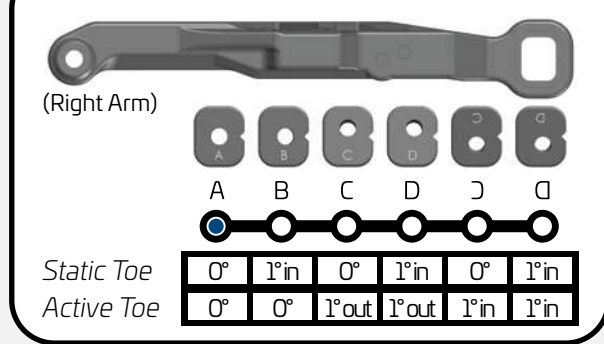

- x4
TKR1201
M3 Locknut Black
- x4
TKR1601
M3x4mm Set Screw
- x2
TKR1603
M5x4mm Set Screw

- x2
TKRBB08165F
Flanged Ball Bearing (8x16x5)

- x2
TKRBB15214
Ball Bearing (15x21x4)

Step
F-2

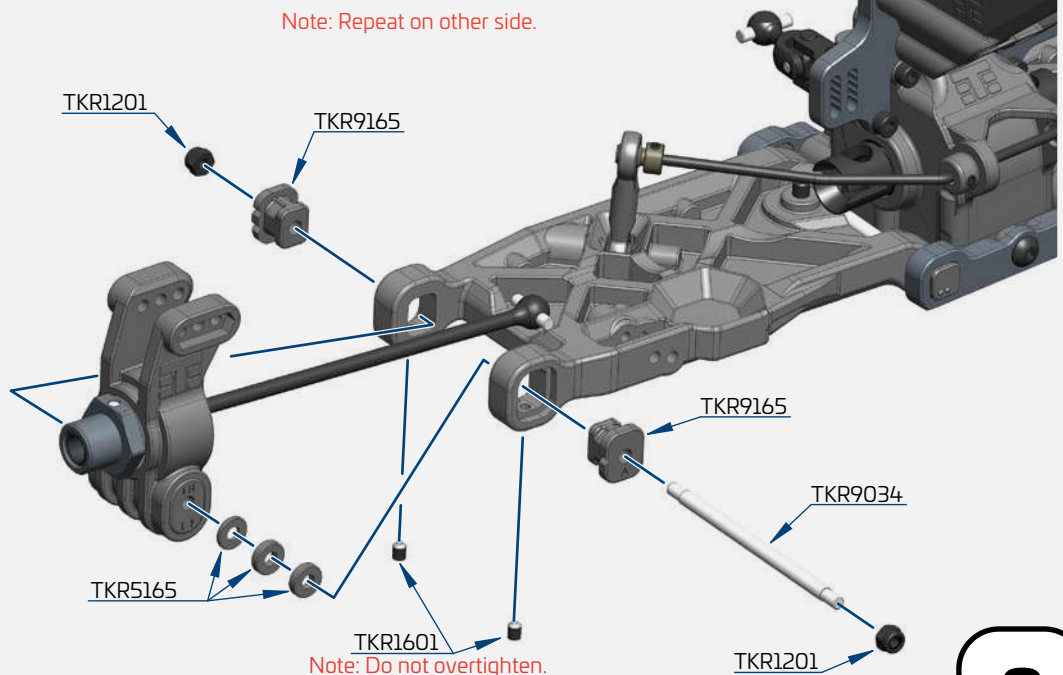

Bag F

Rear Camber Links

Step F-3

Left

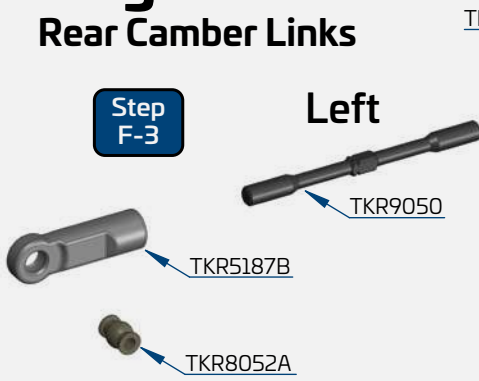

Right

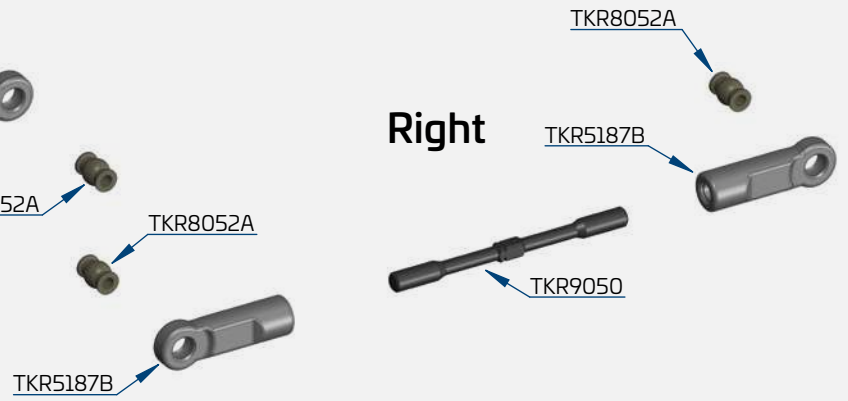

Build Tip: Use some grease or Chapstick on the threads to help prevent "pop-off" when adjustments are being made.

Build Note: Hold the turnbuckle stationary with pliers and push the rod end hard onto the turnbuckle while turning at the same time. Keep in mind that one end of the turnbuckle has normal threads and the other has reverse threads. Start the rod end straight and it will thread on straight.

Note: Notch always goes on left side of vehicle.

Actual Size

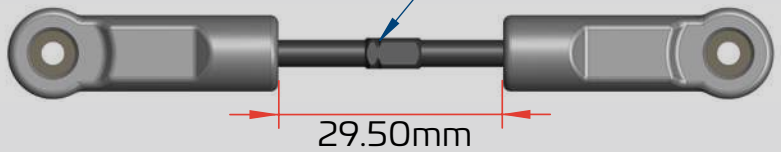

Step F-4



Note: These offset rod ends may be required if running excessive droop. Install on hub side for clearance inside the wheel. These are located inside bag S.

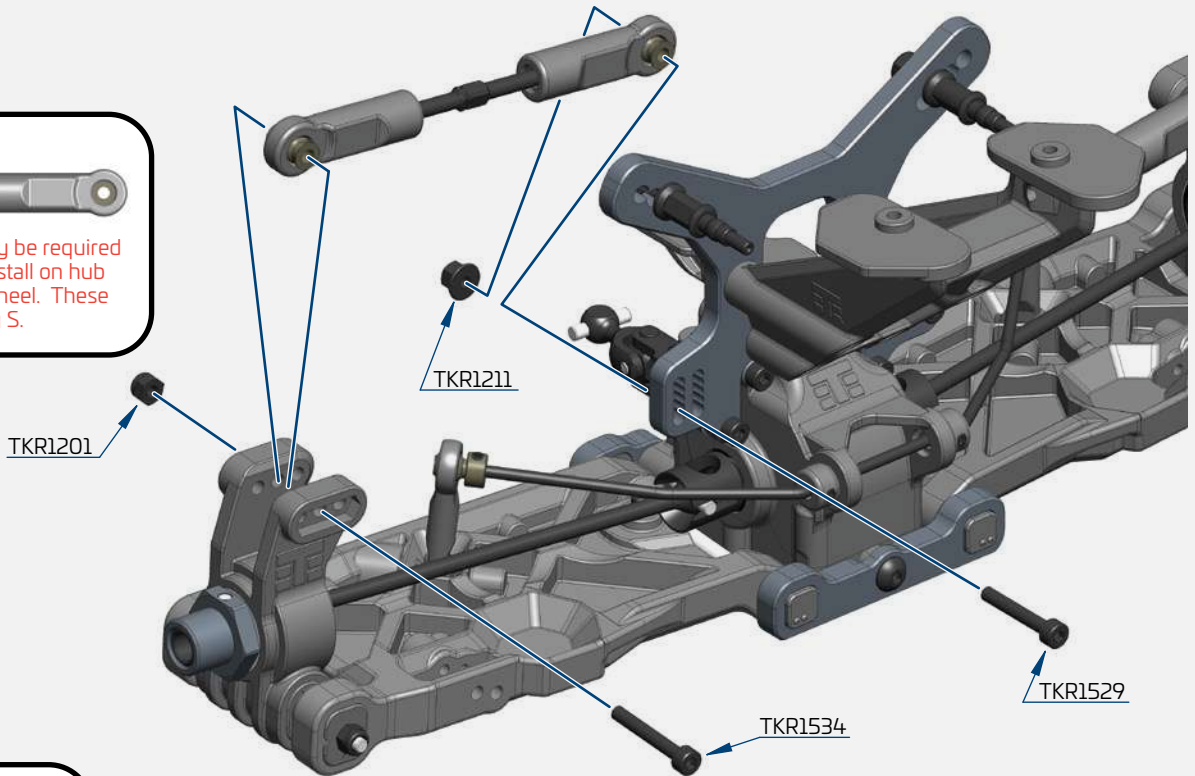

x2

TKR1201
M3 Locknut Black



x2

TKR1211
M3 Lock Nut Flange Black

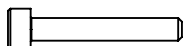

x2

TKR1529
M3x20mm Cap Head Screw

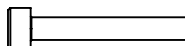

x2

TKR1534
M3x22mm Cap Head Screw

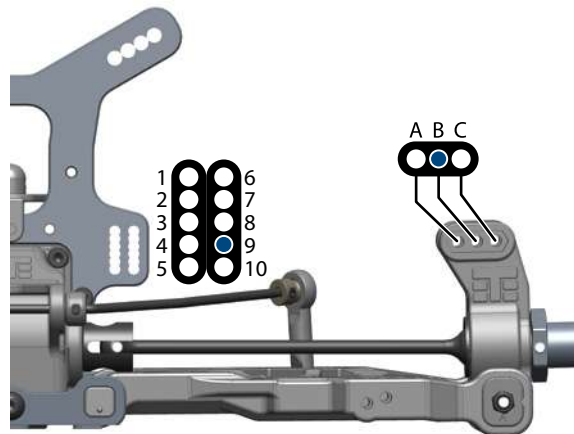

Stock position is 9/B

Bag G Front End Assembly

Optional Sway Bars
(sold separately)
 *TKR9080 - 2.0mm
 *TKR9081 - 2.1mm
 *TKR9082 - 2.2mm
 *TKR9084 - 2.4mm
 *TKR9085 - 2.5mm
 *TKR9086 - 2.6mm
 *TKR9088 - 2.7mm
 *TKR9089 - 2.8mm

Step G-1

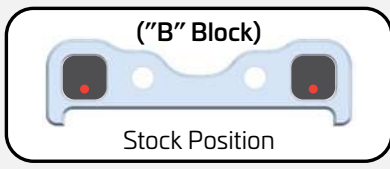
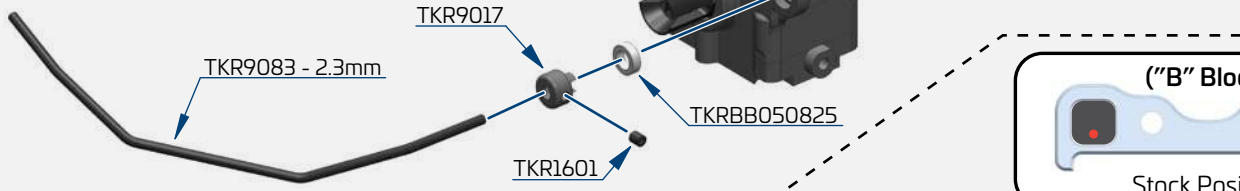

Note: With single dot down
inserts, Kick Up = 11°

Step G-2

*
Thread
Lock

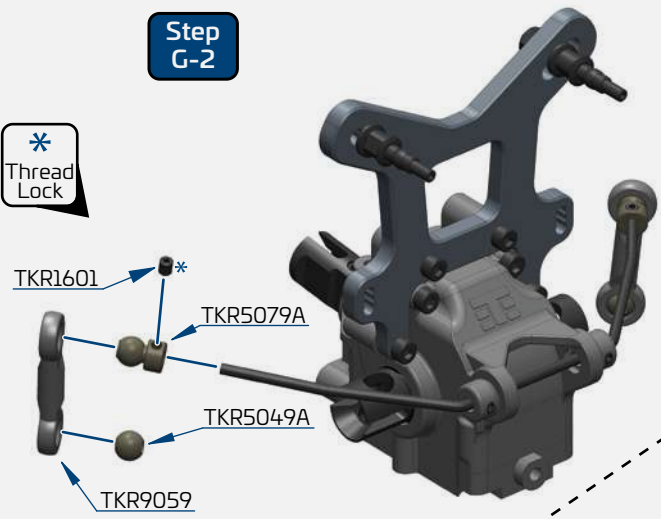

Step G-3

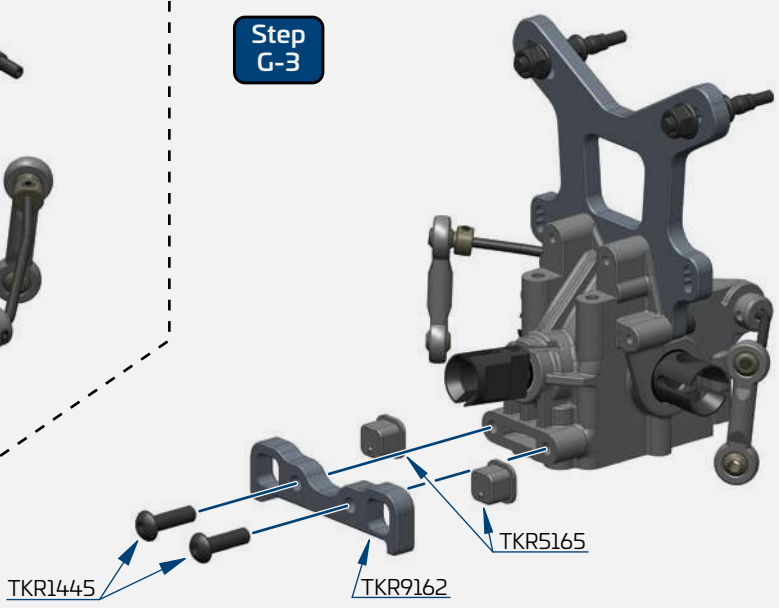

Step G-4

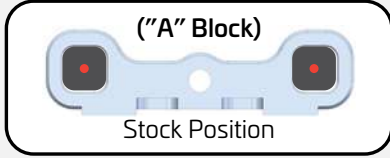

Note: With center dot
inserts, Arm Sweep = 0°

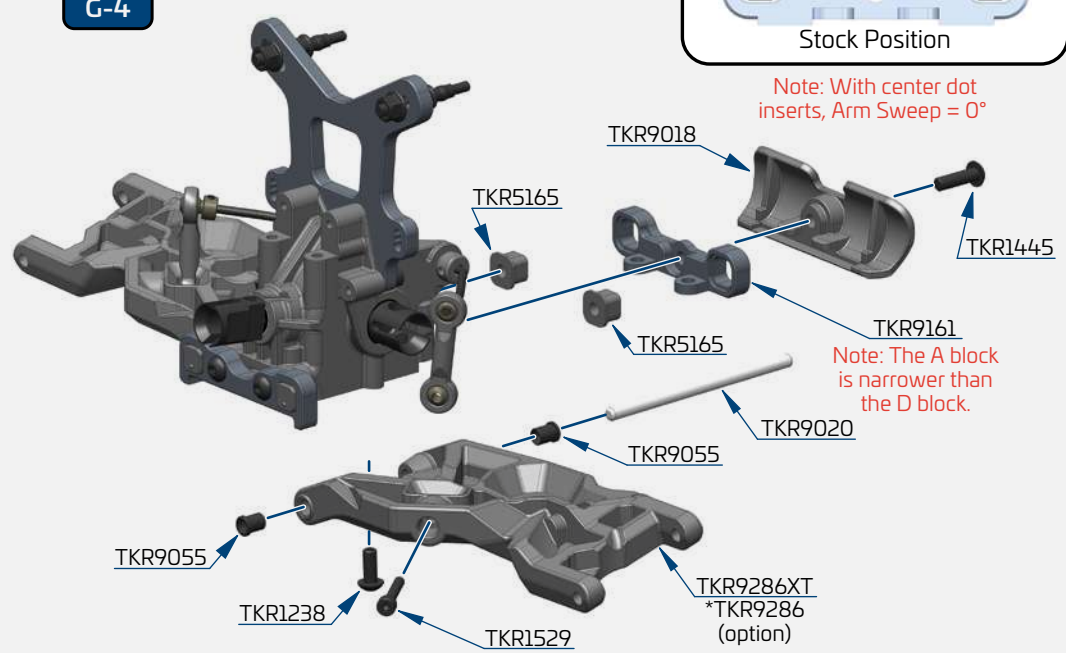

-  x2
TKR1238
M4x10mm Droop Screw
-  x3
TKR1445
M4x14mm Button Head Screw
-  x2
TKR1529
M3x20mm Cap Head Screw
-  x4
TKR1601
M3x4mm Set Screw
-  x2
TKRBB050825
Ball Bearing (5x8x2.5)

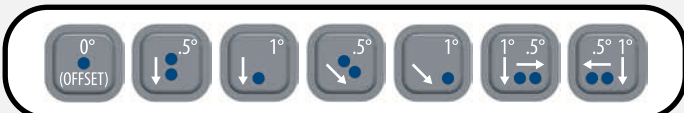

Bag H

Front CVA / Spindle & Carrier Assembly

Step H-1

DO NOT SKIP THIS STEP!

Note: These are steering stop screws. They provide a mechanical limit to the steering throw and make the car easier to drive by greatly improving the consistency of the steering.

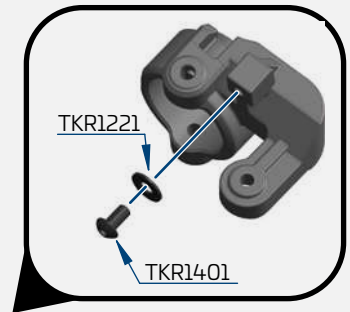

Step H-2

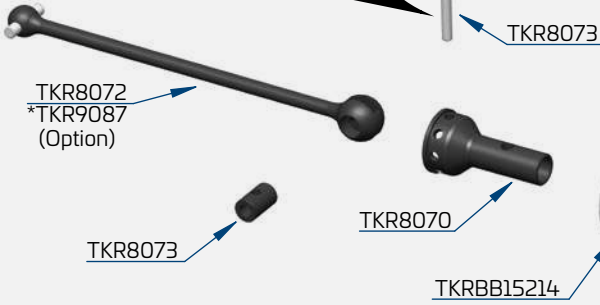

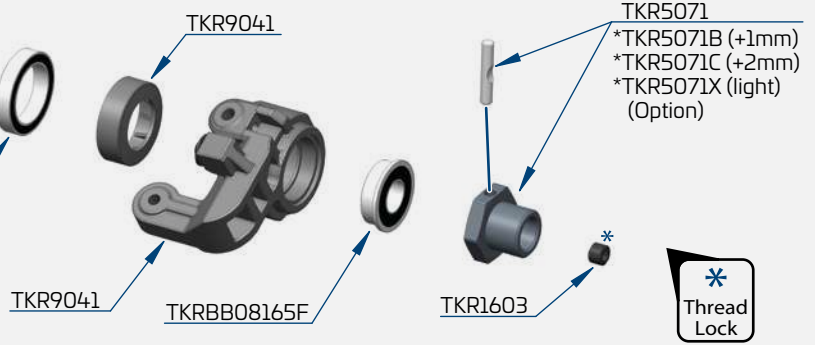

Note: Make left and right side assemblies.



 x2
TKR1221
M3x8mm Washer

 x2
TKR1401
M3x6mm Button Head Screw

 x8
TKR1601
M3x4mm Set Screw

 x2
TKR1603
M5x4mm Set Screw

 x4
TKRBB05104
Ball Bearing (5x10x4)

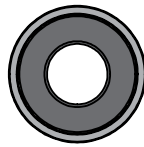
 x2
TKRBB08165F
Flanged Ball Bearing (8x16x5)

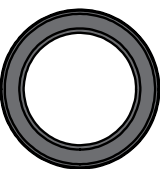
 x2
TKRBB15214
Ball Bearing (15x21x4)

Step H-3

Note: Make left and right side assemblies.

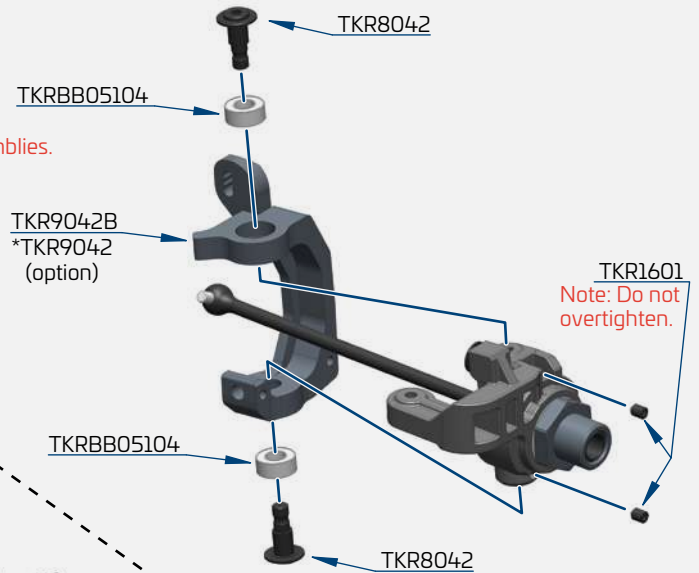

Step H-4

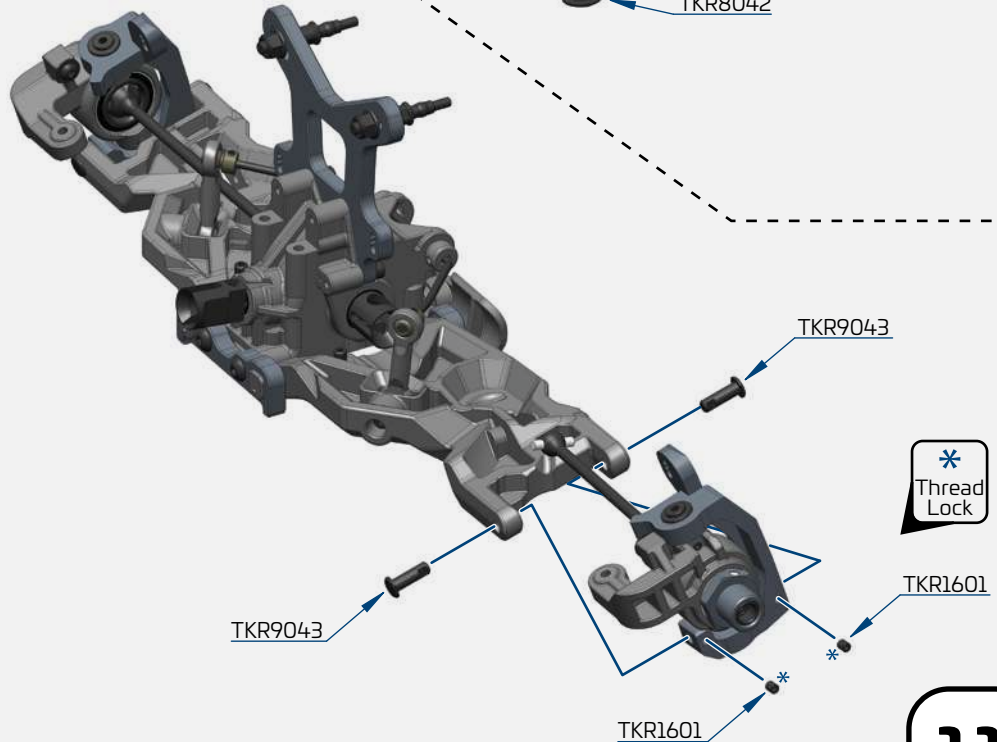

Bag H

Front Camber Links

Step H-5

Left



Right



Build Tip: Use some grease or Chapstick on the threads to help prevent "pop-off" when adjustments are being made.

Build Note: Hold the turnbuckle stationary with pliers and push the rod end hard onto the turnbuckle while turning at the same time. Keep in mind that one end of the turnbuckle has normal threads and the other has reverse threads. Start the rod end straight and it will thread on straight.

Front Camber Links

Note: Notch always goes on left side of vehicle.

Actual Size

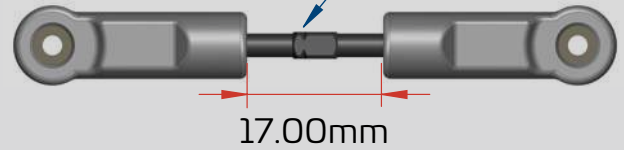

Step H-6

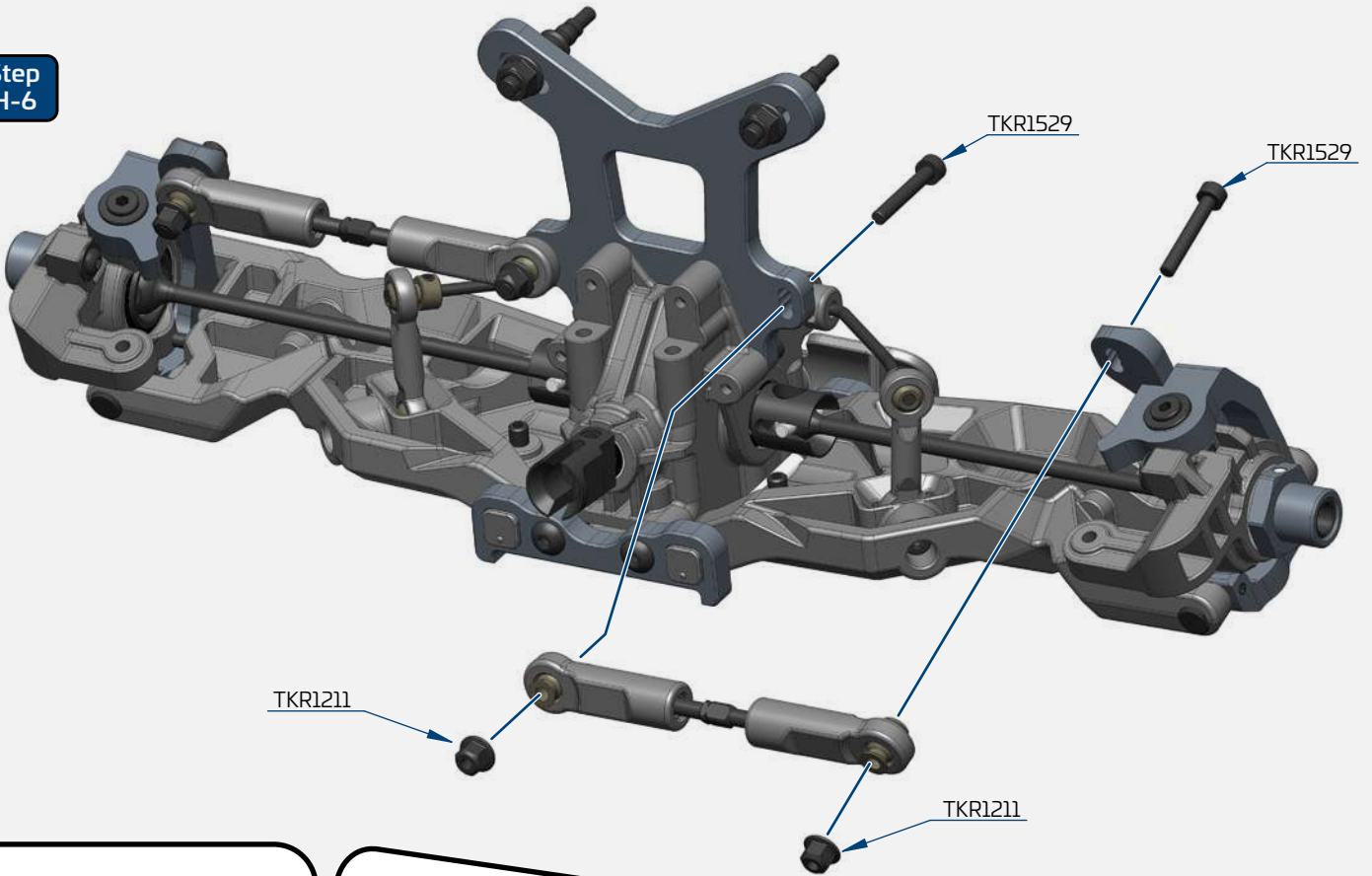

x4
TKR1211
M3 Lock Nut Flange Black

x4
TKR1529
M3x20mm Cap Head Screw

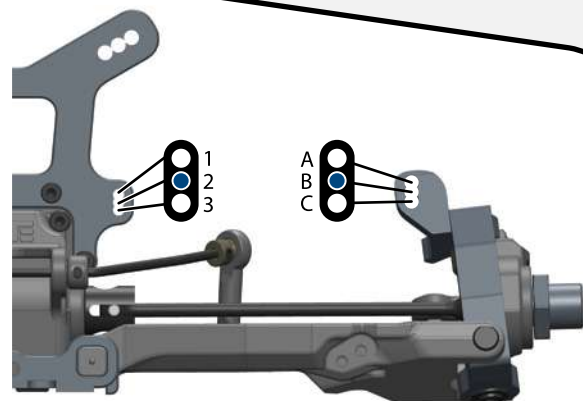

Stock position is 2/B

Bag 1 Steering Assembly

Step
I-1

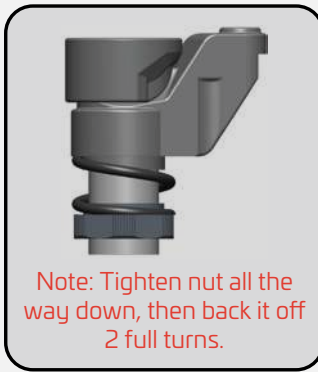
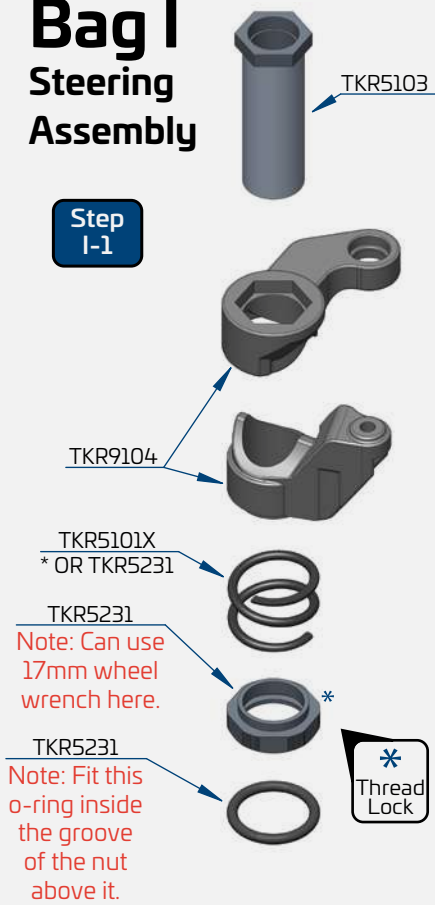



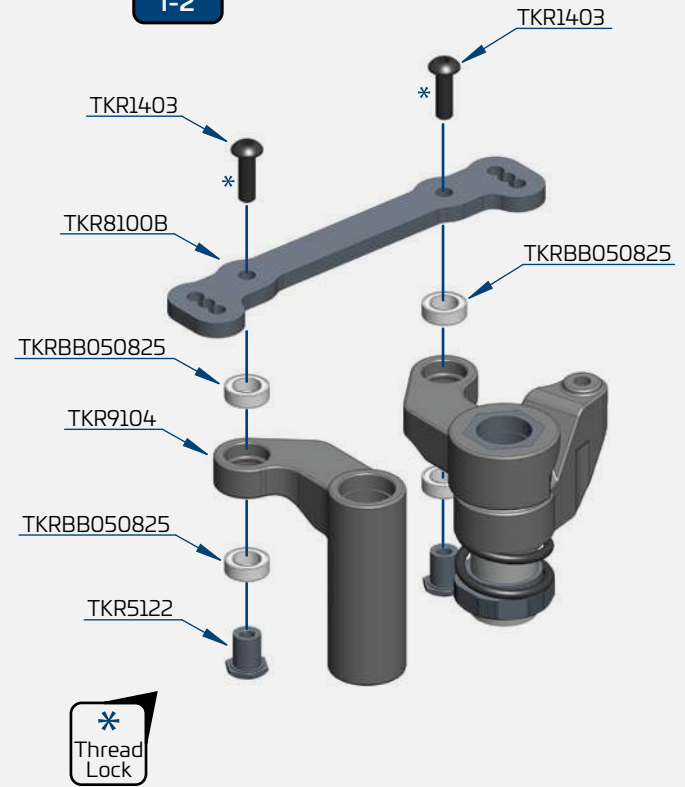

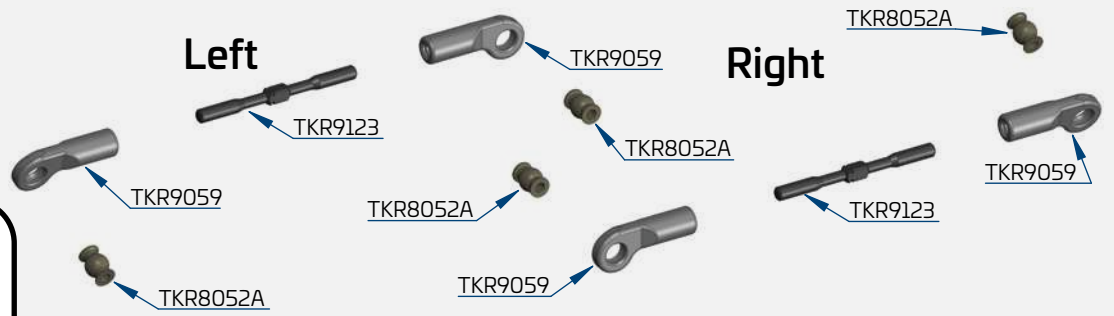

Step
I-2



Step
I-3



-  x2
TKR1201
M3 Lock Nut Black
-  x8
TKR1221
M3x8mm Washer
-  x2
TKR1403
M3x10mm Button Head Screw
-  x2
TKR1529
M3x20mm Cap Head Screw
-  x4
TKRBB050825
Ball Bearing (5x8x2.5)
-  x4
TKRBB06103
Ball Bearing (6x10x3)

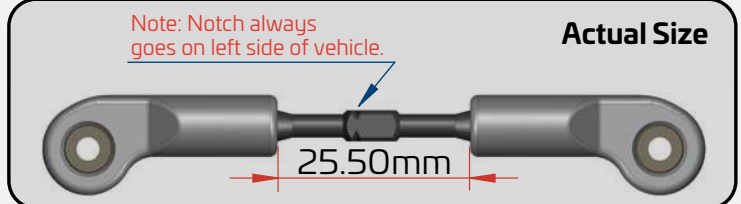

Steering Links

Step
I-4

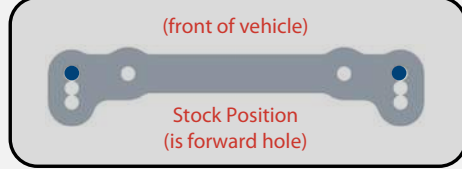
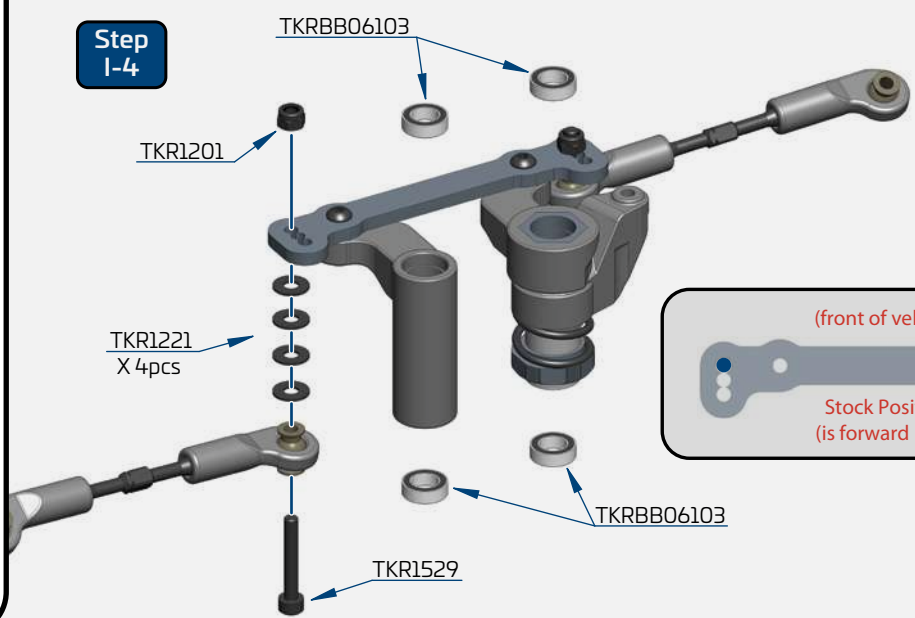

Bag J

Front End Assembly

Step J-1

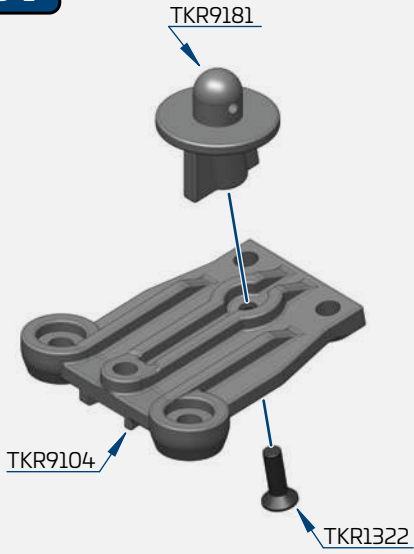

Step J-2

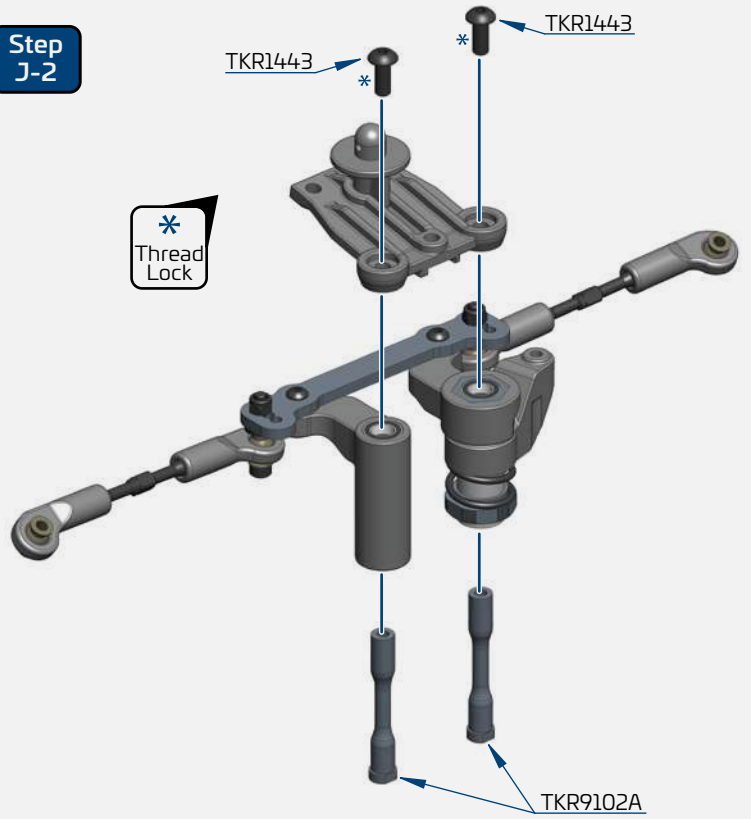

Step J-3

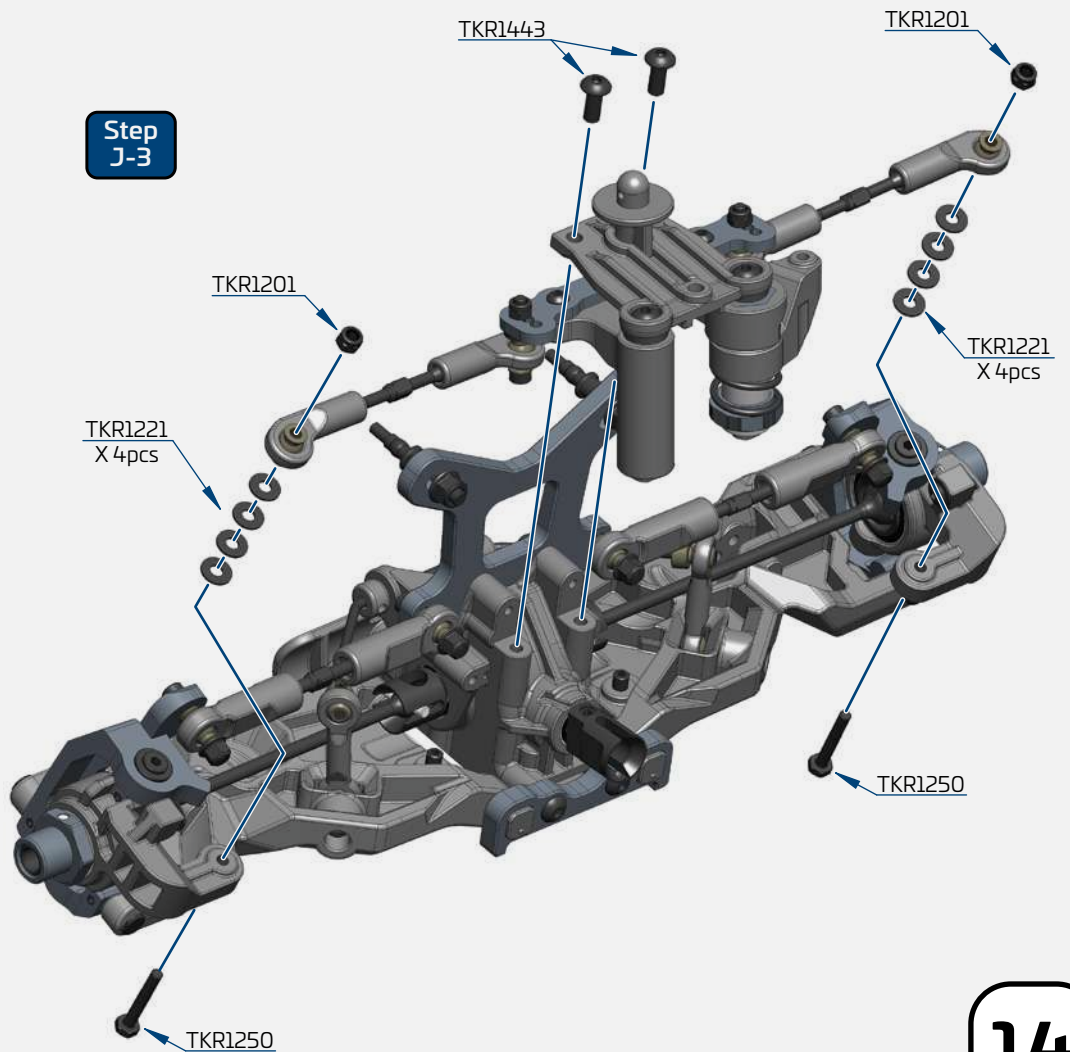

x2
TKR1201
M3 Lock Nut Black

x8
TKR1221
M3x8mm Washer

x2
TKR1250
M3 Steering Link Screw

x1
TKR1322
M3x8mm Flat Head Screw

x4
TKR1443
M4x10mm Button Head Screw

Bag K

Front/Center Assembly

Step K-1

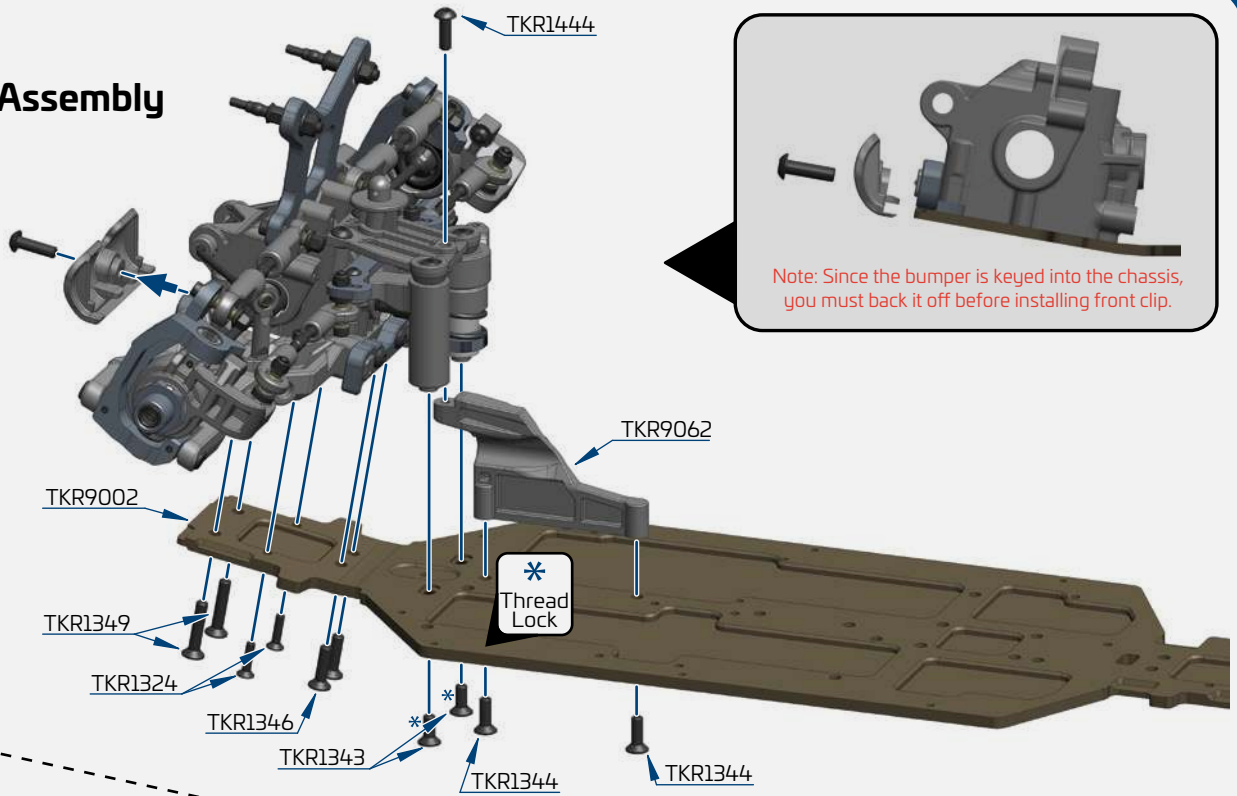

Step K-2

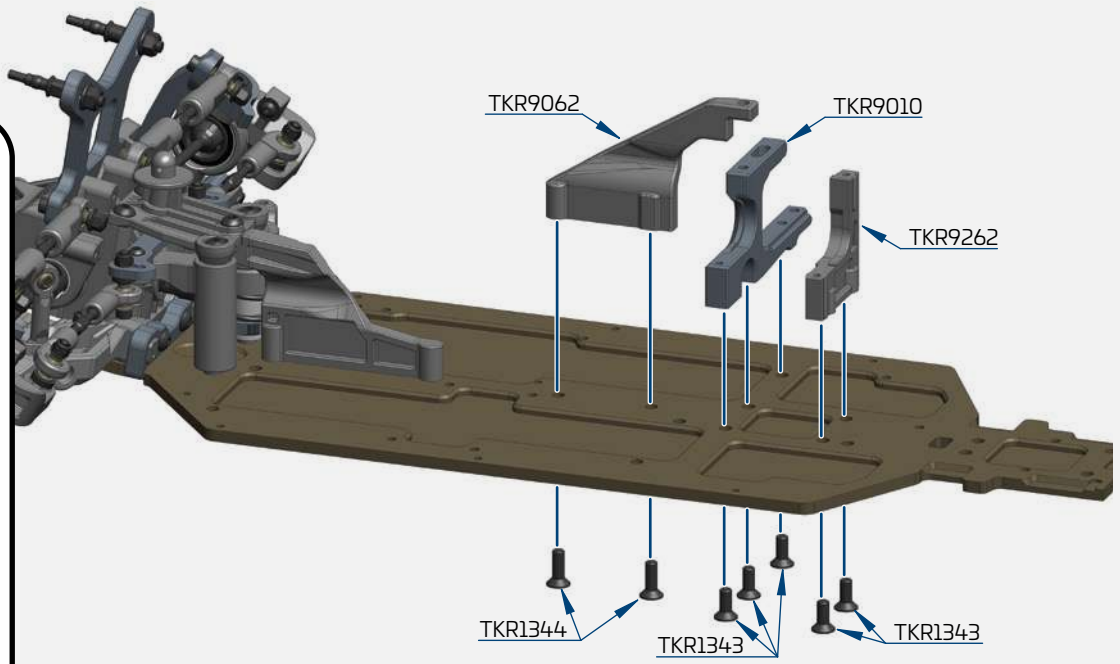

Step K-3

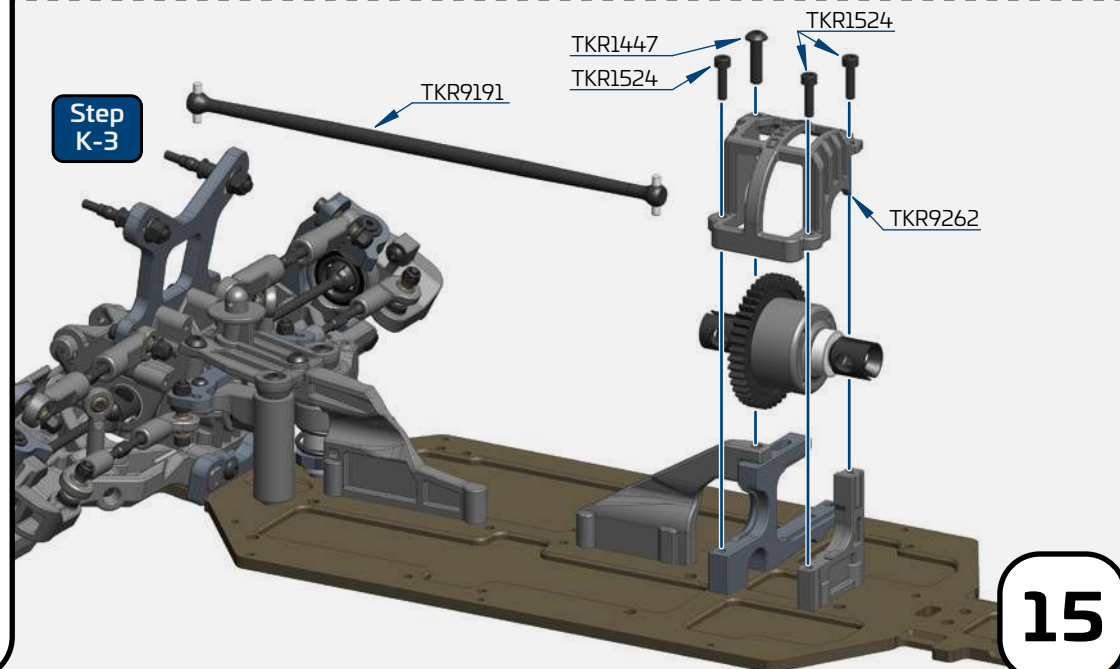

x2
TKR1324
M3x12mm Flat Head Screw

x7
TKR1343
M4x10mm Flat Head Screw

x4
TKR1344
M4x12mm Flat Head Screw

x2
TKR1346
M4x15mm Flat Head Screw

x2
TKR1349
M4x20mm Flat Head Screw

x1
TKR1444
M4x12mm Button Head Screw

x1
TKR1447
M4x16mm Button Head Screw

x3
TKR1524
M3x12mm Cap Head Screw

Bag K

Rear Assembly

Step
K-4

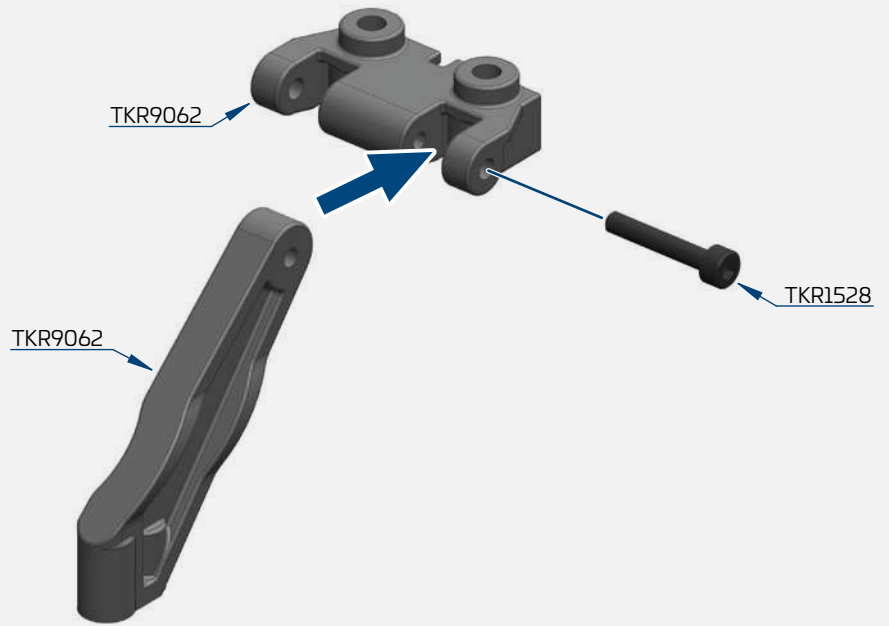

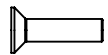

Step
K-5

 x2
TKR1324
M3x12mm Flat Head Screw

 x1
TKR1344
M4x12mm Flat Head Screw

 x2
TKR1346
M4x15mm Flat Head Screw

 x2
TKR1349
M4x20mm Flat Head Screw

 x2
TKR1444
M4x12mm Button Head Screw

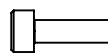
 x1
TKR1528
M3x18mm Cap Head Screw

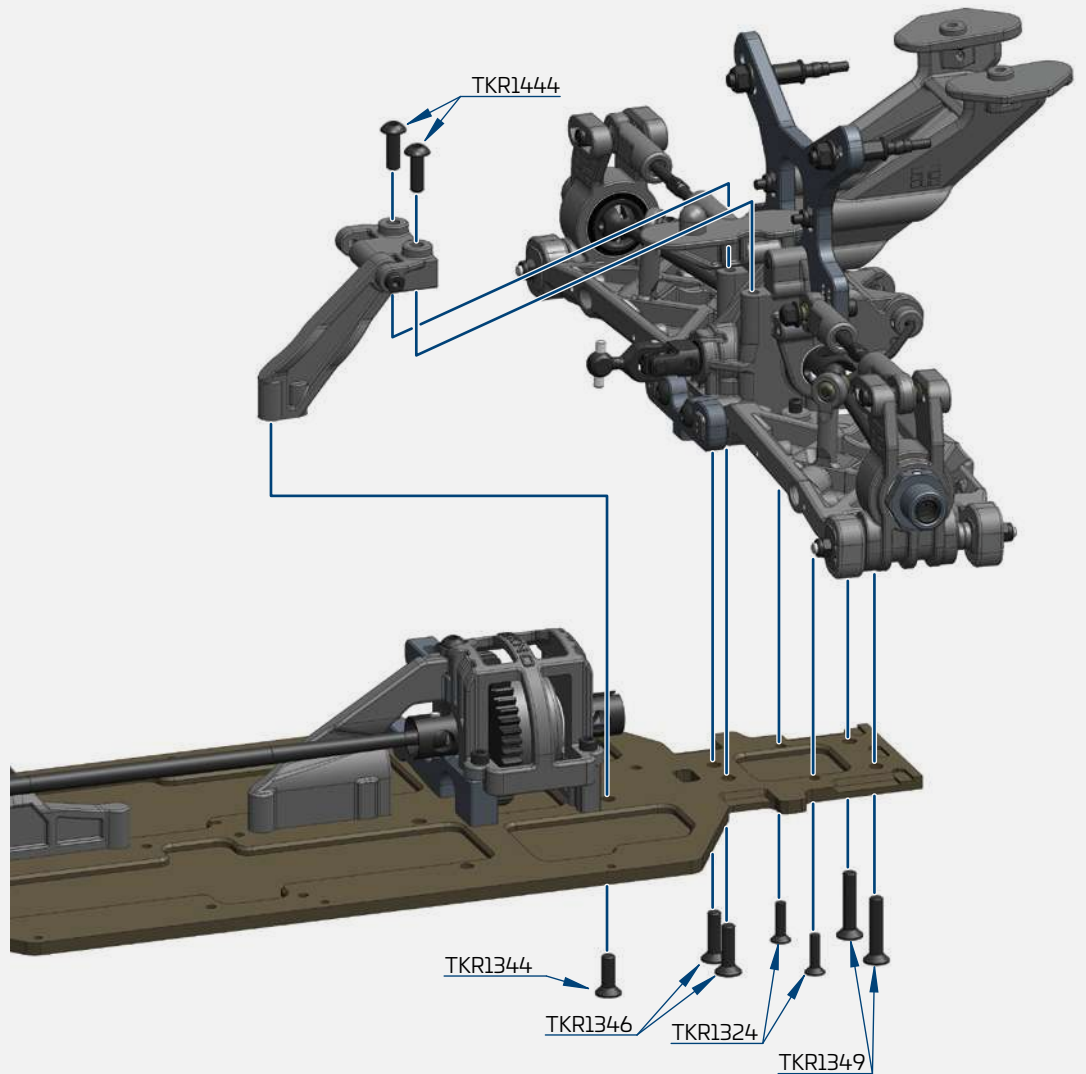

Bag L

Front Shock Assembly

Step L-1

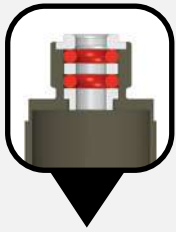

Note: Bottom guide is shorter in the front shocks.

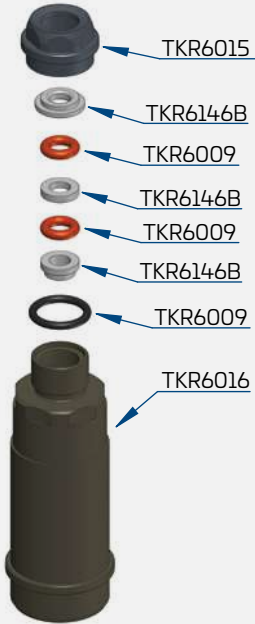

Step L-2



Note: Use green slime or oil on shock shaft threads AND O-rings to prevent tearing and leaking.

Note: Shock boots must be installed BEFORE attaching rod end.

Step L-3

Refer to filling instructions on page 19 during this step.



Note: The kit supplied oil is a great starting point when the ambient temperature is ~75° F.



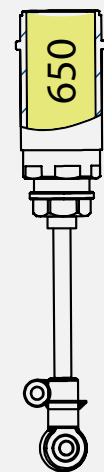

If it is cooler you may need to use thinner oil. Likewise, if it is warmer you may need to use thicker oil.

Use #650 CST oil FRONT

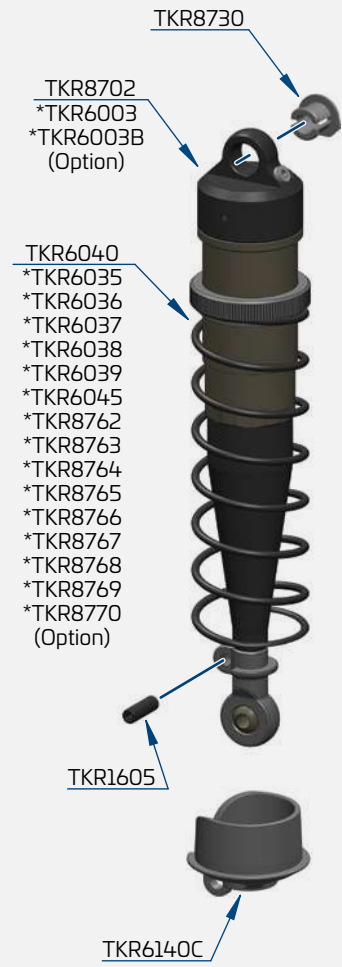

Step L-4



-  x2
TKR1200
M2.5 Lock Nut Zinc
-  x2
TKR1211
M3 Lock Nut Flange Black
-  x2
TKR1240
M3x18mm Shock Mnt Screw
-  x2
TKR1248
M2x4mm Emulsion Screw
-  x2
TKR1605
M3x10mm Set Screw

Step L-5



Note: Slot in spring perch should face outside of vehicle.

TKR1240
Note: Black screw is RH threaded and goes on left side. Silver screw is LH and goes on right side.

- Stock shock position is inside hole on the arm, and middle hole on the tower
- Stock front ride height is 24mm
- Shock length (droop) is 115mm

Bag M

Rear Shock Assembly

Step M-1

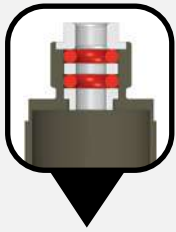

Note: Bottom guide is longer in the rear shocks.

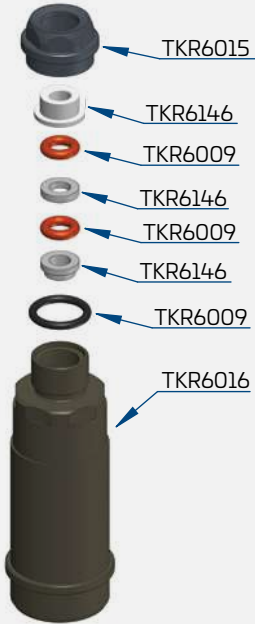

TKR6015

TKR6146

TKR6009

TKR6146

TKR6009

TKR6146

TKR6009

TKR6016

Step M-2



TKR1200

TKR6169

*TKR6160

*TKR6163

*TKR6168

(Option)

TKR6017

*TKR6017T

(Option)

Note: Use green slime or oil on shock shaft threads AND O-rings to prevent tearing and leaking.

TKR6144

Note: Shock boots must be installed BEFORE attaching rod end.

TKR6140C

TKR5049A

TKR6013

Step M-3

Refer to filling instructions on page 19 during this step.



Note: The kit supplied oil is a great starting point when the ambient temperature is ~75° F.

If it is cooler you may need to use thinner oil. Likewise, if it is warmer you may need to use thicker oil.

Use #600 CST oil REAR



Step M-4

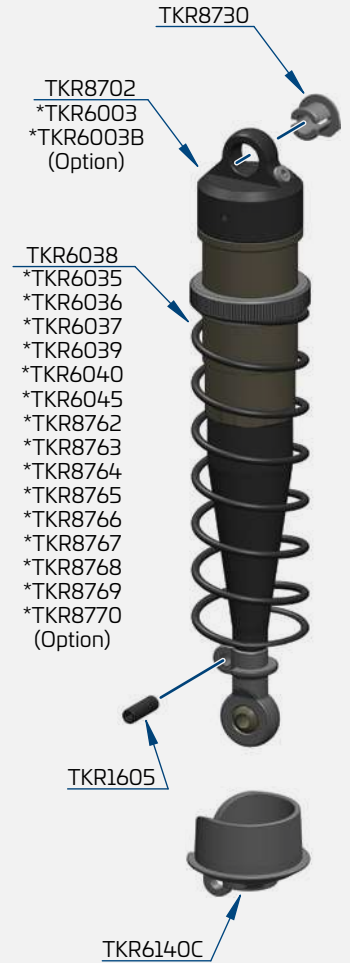

TKR8730

TKR8702

*TKR6003

*TKR6003B

(Option)

TKR6038

*TKR6035

*TKR6036

*TKR6037

*TKR6039

*TKR6040

*TKR6045

*TKR8762

*TKR8763

*TKR8764

*TKR8765

*TKR8766

*TKR8767

*TKR8768

*TKR8769

*TKR8770

(Option)

TKR1605

TKR6140C

Step M-5

 x2
TKR1200
M2.5 Lock Nut Zinc

 x2
TKR1211
M3 Lock Nut Flange Black

 x2
TKR1240
M3x18mm Shock Mnt Screw

 x2
TKR1248
M2x4mm Emulsion Screw

 x2
TKR1605
M3x10mm Set Screw

*
Thread Lock

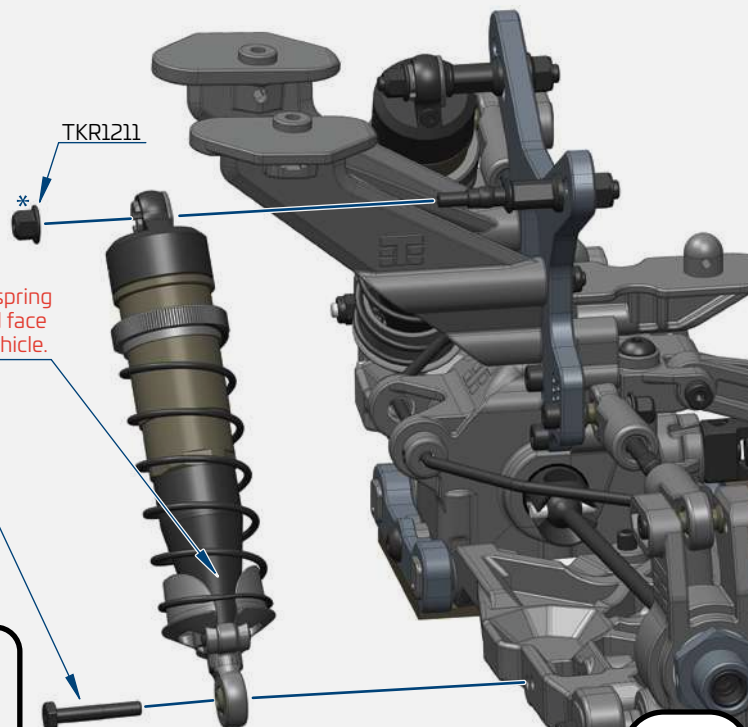

TKR1211

Note: Slot in spring perch should face outside of vehicle.

TKR1240
Note: Black screw is RH threaded and goes on right side. Silver screw is LH threaded and goes on left side.

- Stock shock position is inside hole on the arm, and 2nd hole from the inside on the tower
- Stock rear ride height is 26mm
- Shock length (droop) is 121mm

Shock Filling Instructions

For both front and rear shocks

We've found it's easiest to complete steps 1 & 2 on each shock before moving on to step 3. By the time you've finished step 2 on the last shock, the first one will be ready for step 3.

Step 1. Insert the four larger o-rings into the emulsion caps and set aside. Install the small o-rings onto the small emulsion screws by placing the o-rings on a pit mat or towel and pressing the screws into the o-rings (add 1 small drop of oil onto the seal to help make the screw slide in easier).

Step 2. Fill shock with oil all the way to the top and pump the shock shaft up and down 3-5 times.

Step 3. Screw on the cap all the way tight (shock tool TKR1115 is helpful for holding the shock body). Be careful to not cross-thread the caps. Start by turning in the opposite direction before tightening.

Step 4. With the shock at about a 45° angle, push and hold the shock shaft to the top of the stroke and insert the prepared emulsion screw/seal. Oil should leak out during this process. If it does not, add more oil. Tighten the screw until snug (do not over-tighten). Wipe off excess oil before moving on to step 5.

Step 5. Pump the shock shaft up and down about 20 times vigorously. This emulsifies the oil.

Step 6. With the shock shaft fully extended, remove the emulsion screw from the cap to do the final bleed.

Step 7. With the shock at about a 45° angle, push and hold the shock shaft to the top and insert the prepared emulsion screw/seal again. Oil will leak out during this process. Finish by tightening the screw until snug (do not over-tighten).

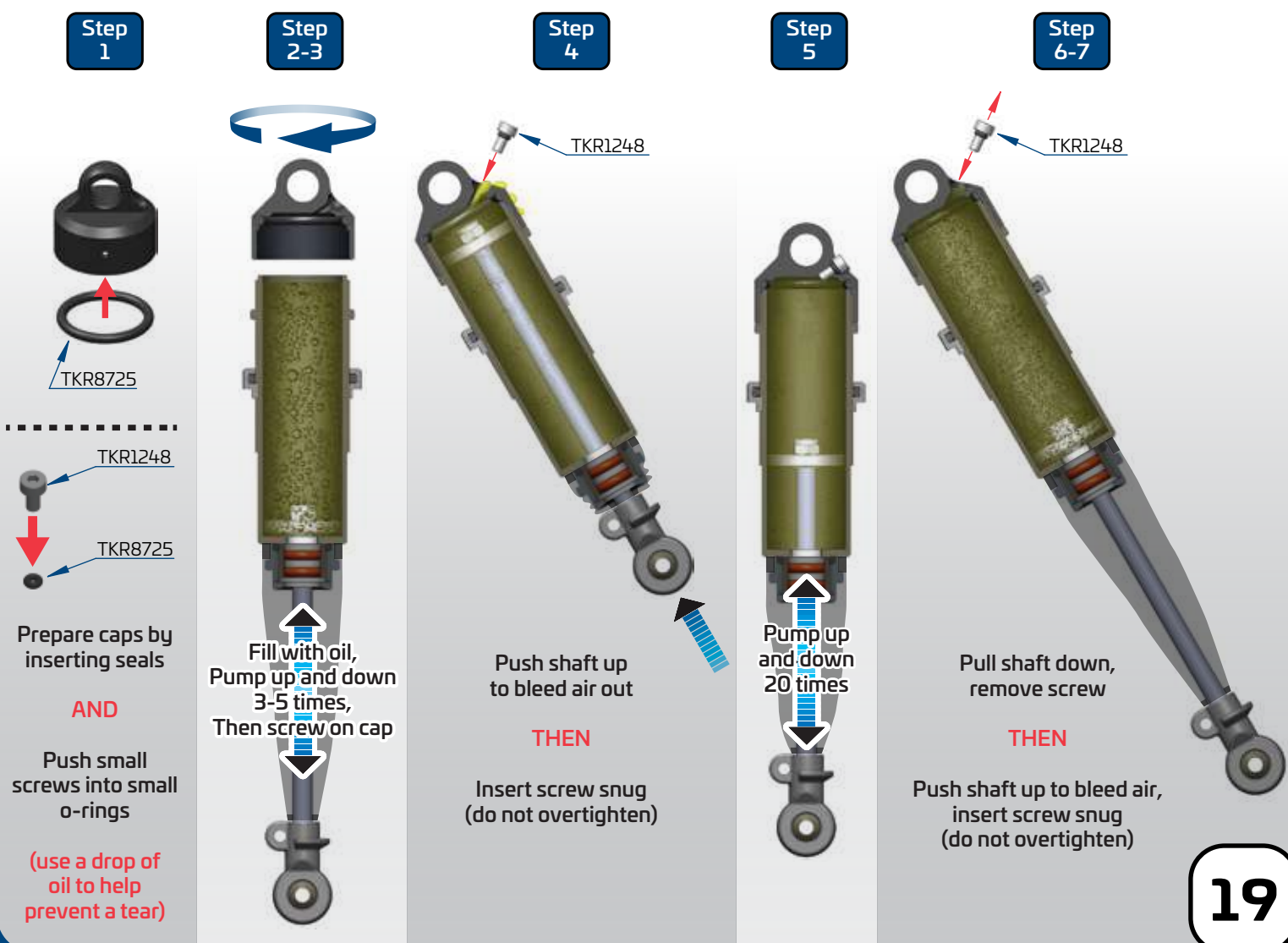

Bag N

ESC/Radio Tray install

Step
N-1

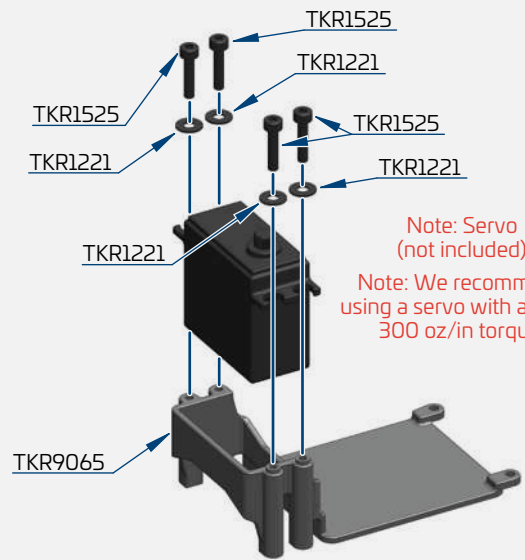

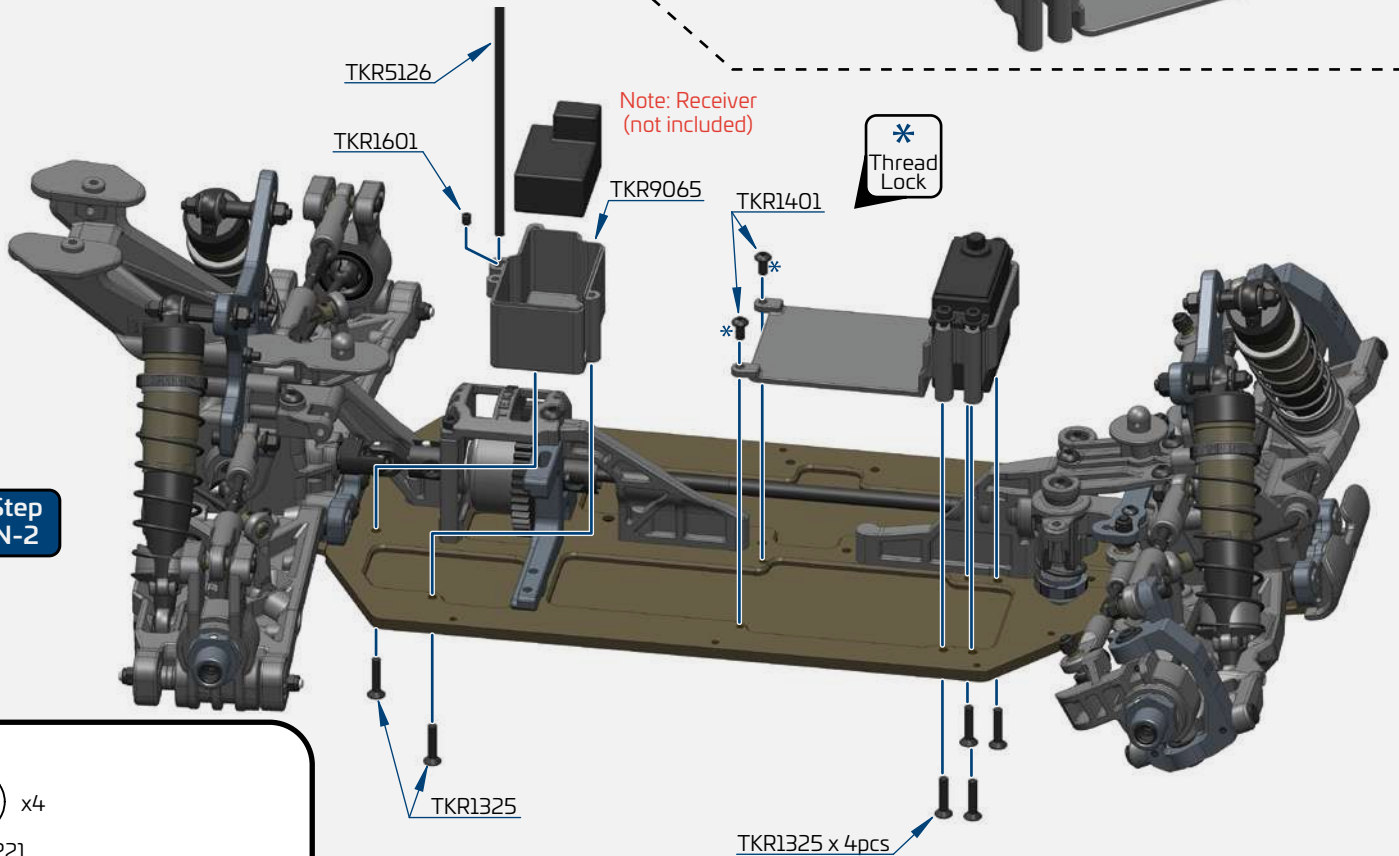

Step
N-2



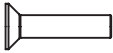

 x4
TKR1221
M3x8mm Washer

 x6
TKR1325
M3x14mm Flat Head Screw

 x2
TKR1401
M3x6mm Button Head Screw

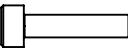
 x6
TKR1402
M3x8mm Button Head Screw

 x4
TKR1525
M3x14mm Cap Head Screw

 x1
TKR1601
M3x4mm Set Screw

Step
N-3

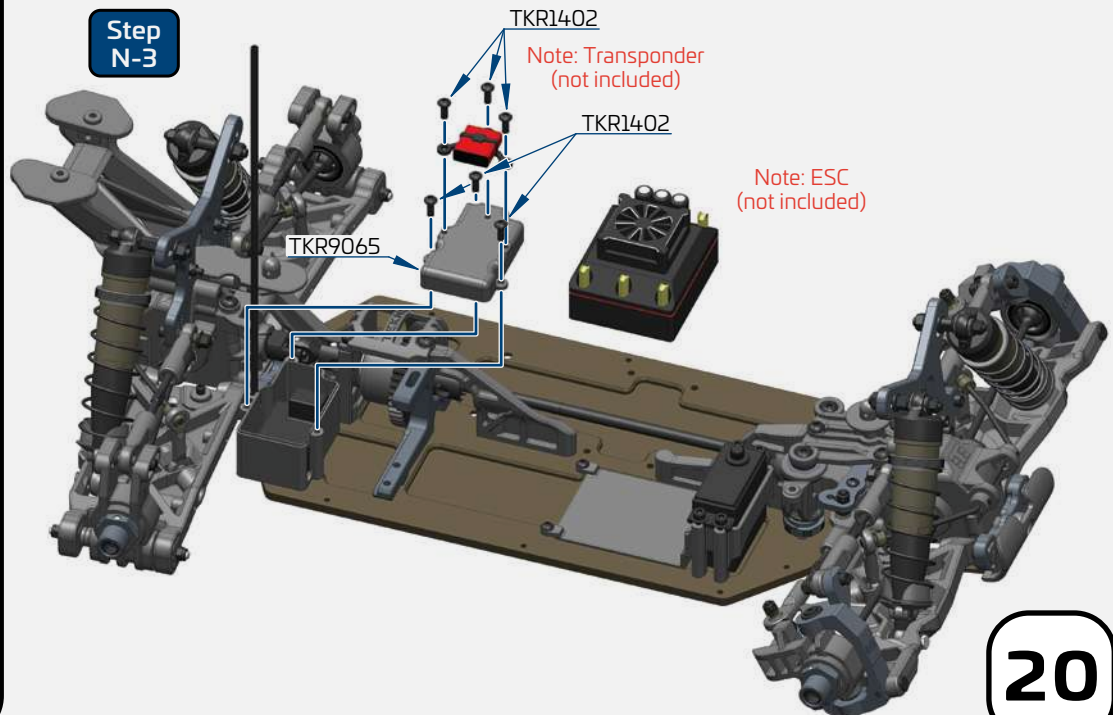

Bag N

Battery Tray/Mud Guard

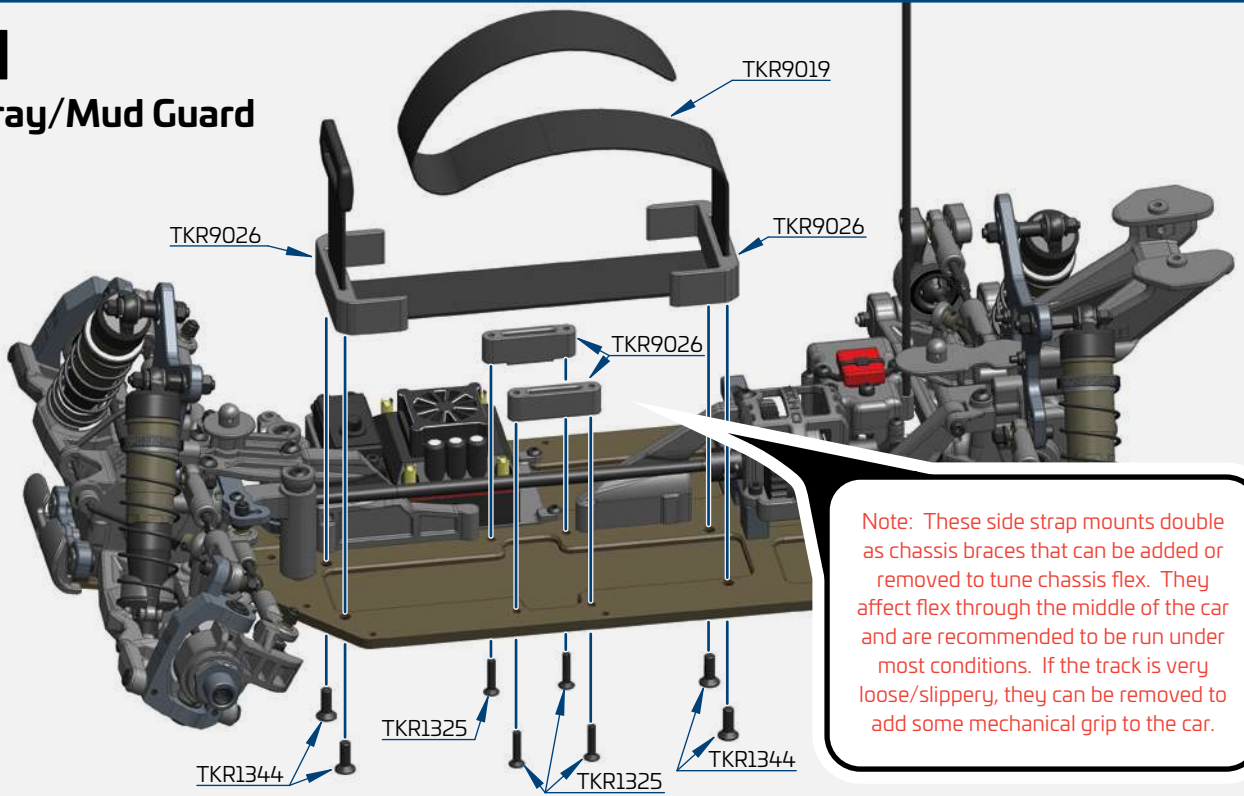

Step
N-4

Note: These side strap mounts double as chassis braces that can be added or removed to tune chassis flex. They affect flex through the middle of the car and are recommended to be run under most conditions. If the track is very loose/slippy, they can be removed to add some mechanical grip to the car.

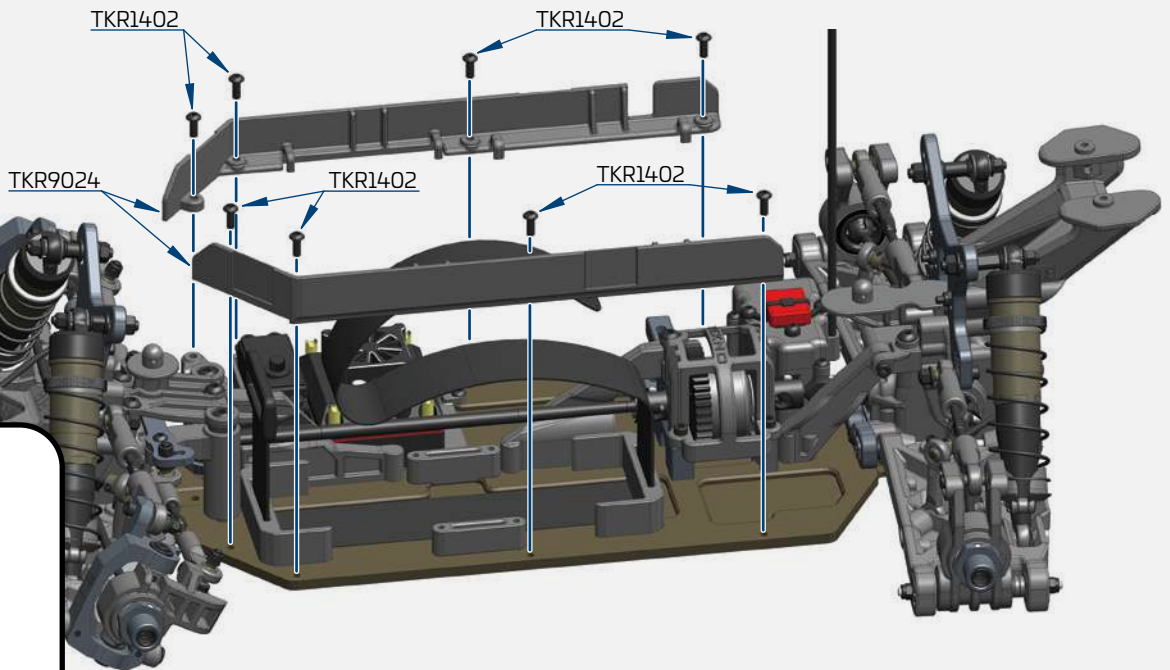

Step
N-5

 x2
TKR1228
M4 Countersunk Washer

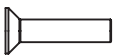
 x4
TKR1325
M3x14mm Flat Head Screw

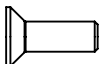
 x4
TKR1344
M4x12mm Flat Head Screw

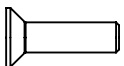
 x2
TKR1346
M4x15mm Flat Head Screw

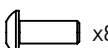
 x8
TKR1402
M3x8mm Button Head Screw

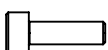
 x2
TKR1523
M3x10mm Cap Head Screw

Step
N-6

Note: Motor, Pinion Gear, & Set Screw for Pinion Gear (not included)

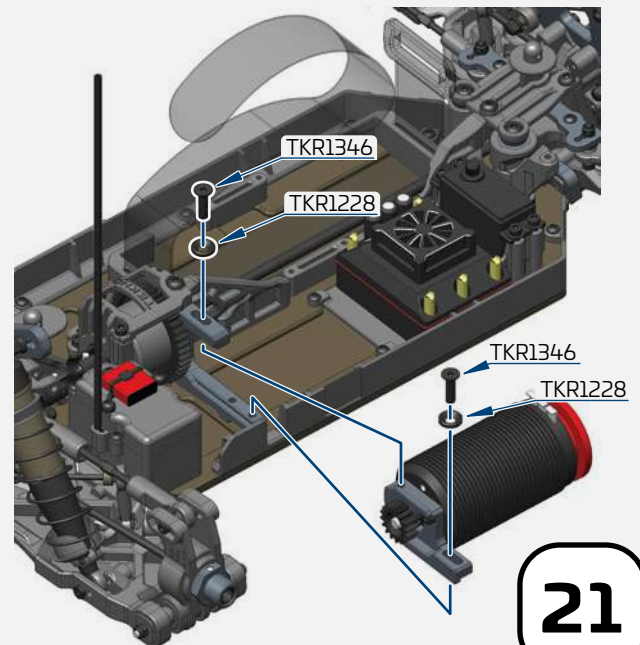

(4 cell) Motor	Small Track (50-100 ft Straight)	Medium Track (100-150 ft Straight)	Large Track (150-200 ft Straight)
1900-2050kv	15 - 16 tooth	16 - 17 tooth	17 - 18 tooth
2050-2200kv	14 - 15 tooth	15 - 16 tooth	16 - 17 tooth

Bag 0

Steering Linkage

Step 0-1

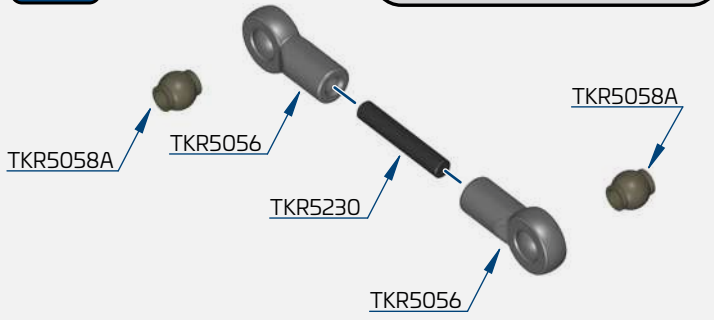

Step 0-2

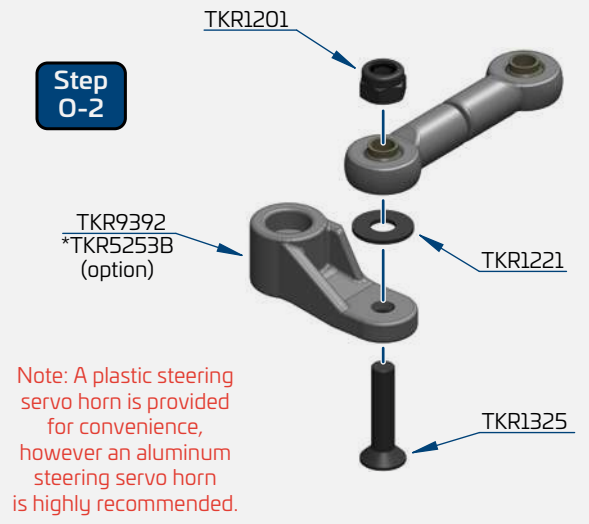

Step 0-3

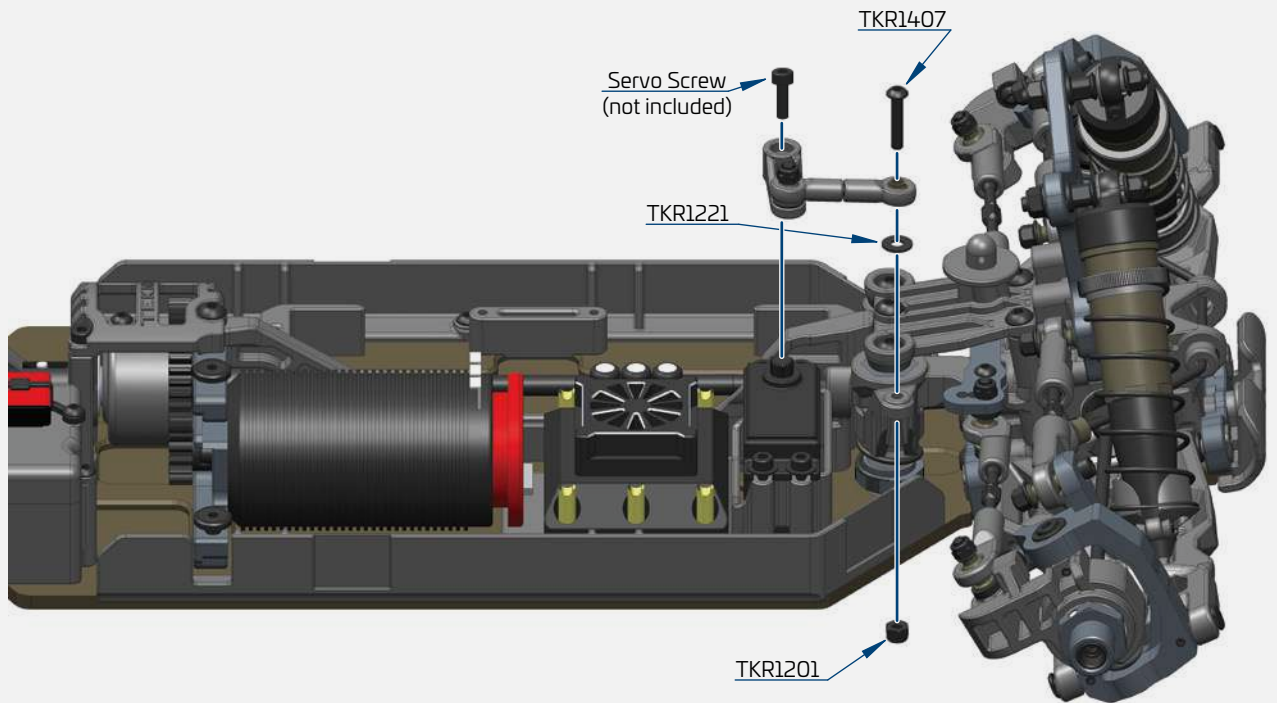

Step 0-4

-  x2
TKR1201
M3 Lock Nut Black
-  x2
TKR1221
M3x8mm Washer
-  x1
TKR1325
M3x14mm Flat Head Screw
-  x1
TKR1407
M3x16mm Button Head Screw

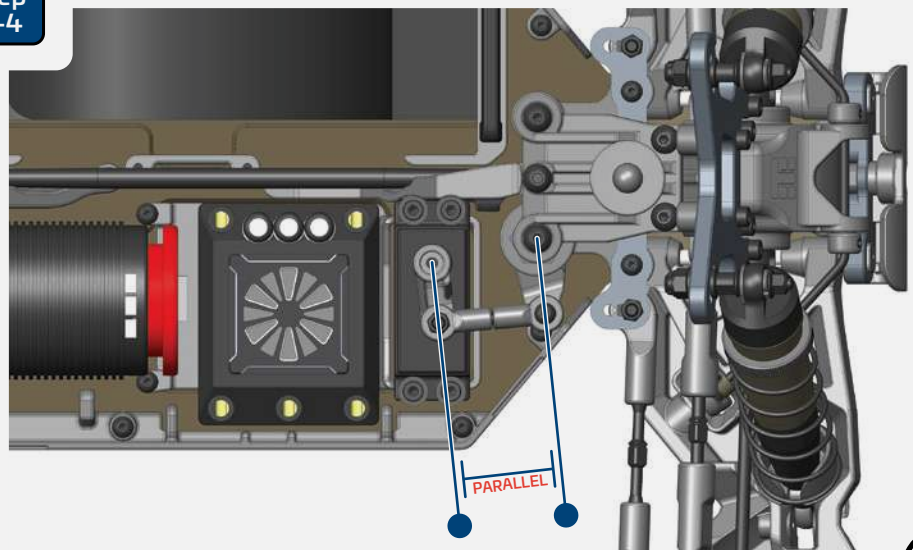

Note: Offset servo arm so it is parallel with the connecting arm at neutral or zero servo position.

Bag P

Final Assembly

Step
P-1

TKR8292W
*TKR8292K
*TKR8292Y
(Option)

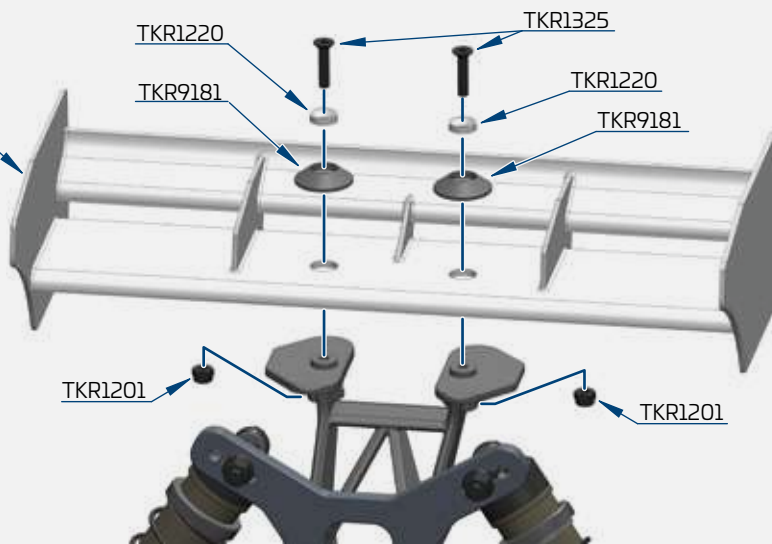

Wing Hole Options

(Use Dimples as Hole Cutting Guides)

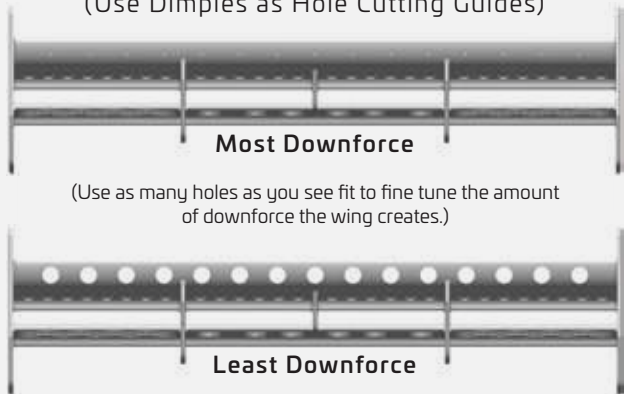

Step
P-2

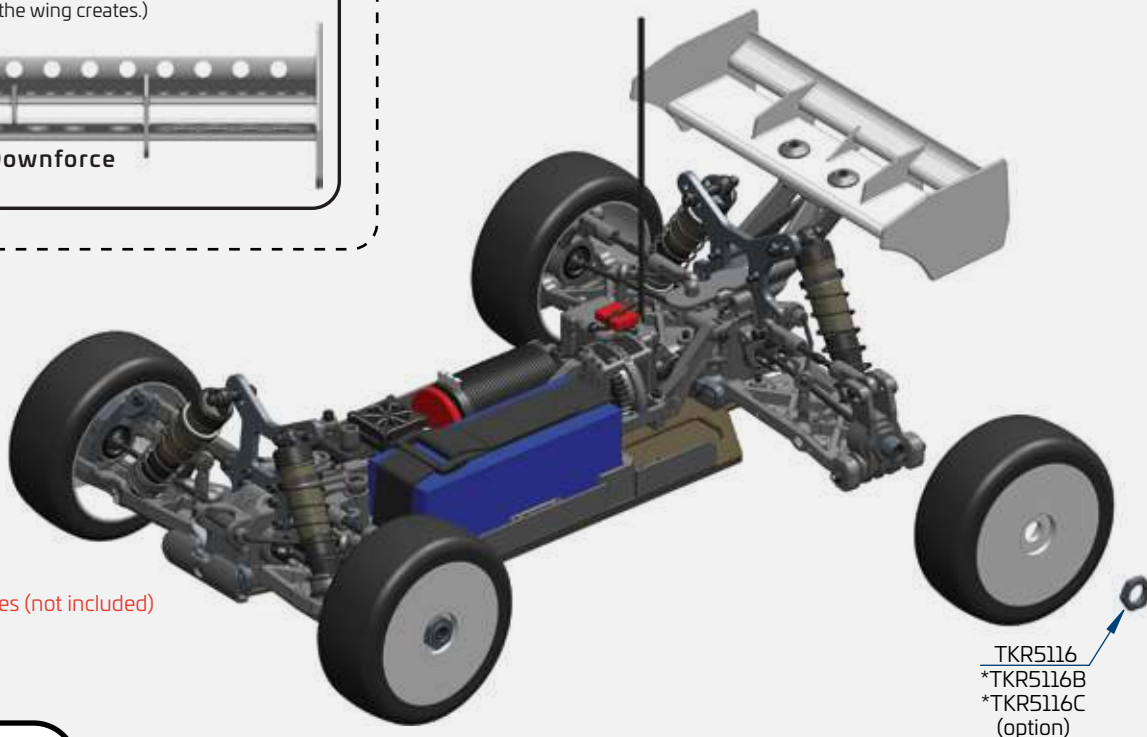

Note: Wheels and tires (not included)



x2

TKR1201
M3 Lock Nut Black



x2

TKR1220
M3 Countersunk Washer

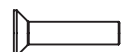

x2

TKR1325
M3x14mm Flat Head Screw



x2

TKR1235
Body Clip

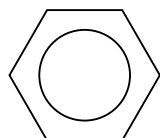

x4

TKR5116
Wheel Nut

Step
P-3

Note: It may be necessary to cut holes in the body for ventilation.

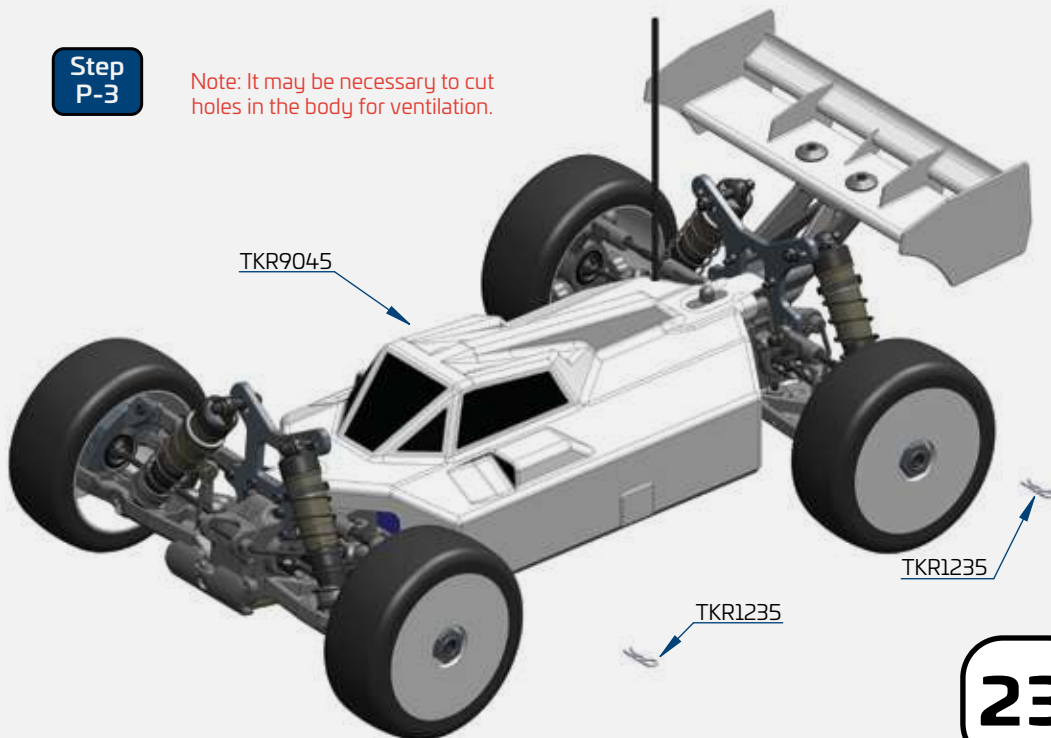

TKR9000 - EB48 2.0 1/8th 4WD Competition Electric Buggy Kit

Parts List

TKR5049A – Pivot Balls (6.8mm, no flng, sway bar, shck ends, almm, 4pcs)
TKR5058A – Pivot Balls (5.8mm, no flange, brake/steering link, aluminum, 4pcs)
TKR5071 – Wheel Hubs (17mm, aluminum, gun metal ano, w/pins, 2pcs)
TKR5079A – Stabilizer Balls (6.8mm, sway bars, aluminum, 4pcs)
TKR5101X – Servo Saver Spring (HD, EB48, SCT4.10, NB48)
TKR5103 – Servo Saver Post (aluminum, gun metal ano)
TKR5116 – Wheel Nuts (17mm, serrated, gun metal ano, M12x1.0, 4pcs)
TKR5122 – Steering Rack Bushings (aluminum, gun metal ano, 2pcs)
TKR5126 – Antenna tube (universal, w/ caps, 5pcs)
TKR5165 – V2 Hinge Pin Inserts, Wheelbase Shims (EB/NB/ET/NT/SCT)
TKR5187B – Rod Ends (hard, 6.8mm, EB/NB/ET/NT48, 8pcs)
TKR5230 – Steering Linkage (M3x18mm threaded rod, 10pcs)
TKR5231 – Servo Saver Nut and Spring
TKR8042 – Kingpin Shoulder Screws (EB/NB48.4, 4pcs)
TKR8052A – Pivot Balls (6.8mm, camber, str links, almm, centered, 4pcs)
TKR8070 – Stub Axles (hardened steel, 2pcs)
TKR8072 – Driveshafts (f/r, hardened steel, 2pcs)
TKR8073 – CV Rebuild Kit (front/rear, for 2 axles)
TKR8100B – Ackerman Plate (7075, EB/NB48 2.0)
TKR8292W – Lightweight Wing (ROAR/IFMAR legal, white)
TKR9002 – Chassis (7075, hard anodized, EB48 2.0)
TKR9010 – Split Center Diff Mount (7075, gun metal ano, EB/ET48 2.0)
TKR9011 – Motor Mount Insert (7075, gun metal ano, EB/ET48 2.0)
TKR9012 – Gearbox (front, 2.0)
TKR9016 – Gearbox (rear, 2.0)
TKR9017 – Sway Bar and Bulkhead Acc (2.0)
TKR9018 – Front Bumper (2.0, 2pcs)
TKR9019 – Battery Straps (1x center, 1x side, EB/ET48 2.0)
TKR9020 – Hinge Pins (inner, front/rear)
TKR9024 – Mud Guard Set (L/R, EB/ET48 2.0)
TKR9026 – Battery Strap Mounts (EB/ET48 2.0)
TKR9034 – Hinge Pins (outer, rear, 2.0, 2pcs)
TKR9040 – Rear Hubs and Bearing Spacers (L/R, 2.0)
TKR9041 – Spindles and Bearing Spacers (L/R, 2.0)
TKR9042B – Spindle Carriers (L/R, 7075, 18 degree, 2.0)
TKR9043 – Spindle Carrier Hinge Pins (steel, 2.0, 4pcs)
TKR9045 – Body (EB48 2.0, w/ window mask)
TKR9049 – Turnbuckle (M5 thread, 50mm length, 4mm adjustment, 2pcs)
TKR9050 – Turnbuckle (M5 thread, 65mm length, 4mm adjustment, 2pcs)
TKR9055 – Hinge Pin Bushings (8pcs)
TKR9059 – Rod End Set (brake/steering/sway bar linkage, 2.0)
TKR9062 – Chassis Brace Set (front/rear/center, EB/ET48 2.0)
TKR9065 – Servo Mount, ESC tray, RX Box (EB/ET48 2.0)
TKR9083 – Sway Bar (front, 2.3mm)
TKR9095 – Universal Driveshaft (center, rear, 17mm, EB48 2.0)
TKR9102A – Steering Posts (aluminum, gun metal ano)
TKR9104 – Bell Cranks and Top Plate (2.0)
TKR9123 – Turnbuckle (M4 thread, 50mm length, 4mm adjustment, 2pcs)
TKR9161 – Hinge Pin Brace (CNC, 7075, EB/NB48 2.0, A Block)
TKR9162 – Hinge Pin Brace (CNC, 7075, EB/NB48 2.0, B Block)
TKR9163 – Hinge Pin Brace (CNC, 7075, EB/NB48 2.0, C Block)
TKR9164 – Hinge Pin Brace (CNC, 7075, EB/NB48 2.0, D Block)
TKR9165 – Rear Arm Hinge Pin Inserts (2.0)
TKR9166 – Rear Hub Roll Center Inserts (2.0)
TKR9181 – Wing Mount and Body Mounts (2.0)
TKR9184XT – Suspension Arms (rear, extra tough, EB/NB48 2.0)
TKR9191 – Tapered Driveshaft (center, front, 7075, black ano, EB/ET48 2.0)
TKR9194 – Sway Bar (rear, 2.5mm)
TKR9246 – Decal Sheet (EB48 2.0)
TKR9262 – Split Center Diff Mount (composite, requires TKR9010, EB/ET48 2.0)
TKR9268 – Shock Tower (front, 7075 CNC, gun metal ano, EB/NB48 2.0)
TKR9269S – Shock Tower (rear, short, 7075 CNC, gun metal ano, EB/NB48 2.0)
TKR9286XT – Suspension Arms (front, extra tough, EB/NB48 2.0)

Bearings List

TKRBB050825 – Ball Bearing (5x8x2.5mm, 4pcs)
TKRBB05104 – Ball Bearing (5x10x4, 4pcs)
TKRBB05114 – Ball Bearing (5x11x4, 4pcs)
TKRBB05145 – Ball Bearing (5x14x5, shielded, 4pcs)
TKRBB06103 – Ball Bearing (6x10x3, 4pcs)
TKRBB08165 – Ball Bearing (8x16x5, 4pcs)
TKRBB08165F – Ball Bearing (8x16x5mm, flanged, shielded, 4pcs)
TKRBB15214 – Ball Bearing (15x21x4, shielded, 4pcs)

Shocks List

TKR6009 – Shock O-Ring and Bladder Set (for 2 shocks)
TKR6013 – Shock Adjustment Nuts (aluminum, gun metal ano, 2pcs)
TKR6015 – Shock Cartridge Caps (aluminum, gun metal ano, 2pcs)
TKR6016 – Shock Body (rear, aluminum, hard ano, 2pcs)
TKR6017 – Shock Shafts (rear, steel, 2pcs)
TKR6038 – Shock Spring Set (front, 1.5 x 7.5T, 70mm, orange)
TKR6040 – Shock Spring Set (front, 1.5 x 6.75, 5.65lb/in, 70mm, blue)
TKR6140C – Locking Shock Rod End and Spring Perch Set (revised, EB/NB/ET/NT/SCT)
TKR6144 – Shock Boots (long length, EB/NB, 2pcs)
TKR6146 – Shock Cartridge Set (CNC, Delrin, EB/NB/ET/NT/SCT)
TKR6146B – Shock Cartridge Set (revised, CNC, Delrin, EB/NB/ET/NT/SCT)
TKR6169 – Shock Pistons (CNC, flat/flat, 5x1.5 + 2x1.0)
TKR8702 – Shock Caps (7075, emulsion/vented/standard, black ano, 2pcs)
TKR8725 – Emulsion O-ring Set (4x cap seals, 8x emulsion o-rings, for 16mm shocks)
TKR8727 – Shock Standoffs (2pcs, requires TKR8730)
TKR8727X – Shock Standoffs (+4mm, requires TKR8730, fits TKR8702, TKR6003/B, 2pcs)
TKR8730 – Shock Cap Bushings (4pcs, requires TKR8727)

Differential List

TKR5144 – Differential O-Rings (6pcs)
TKR5145B – Differential Shims (revised, 6x17mm, 6pcs)
TKR9114 – Differential Outdrives (F/R NB/NT48 2.0, F/C/R EB/ET48 2.0, 2pcs)
TKR9115 – Differential Case (F/R NB/NT48 2.0, F/C/R EB/ET48 2.0)
TKR9143 – Differential Seals (2.0, 3pcs)
TKR9149 – Differential Cross Pins (2.0, 6pcs)
TKR9150 – Differential Gear Set (internal gears only, 2.0)
TKR9151 – Differential Ring Gear (CNC, 40t, use with TKR9153)
TKR9153 – Diff Pinion (12t, CNC, use with TKR9151)
TKR9237 – Spur Gear (44T, composite, EB/ET48 2.0)

Hardware List

TKR1200 – M2.5 Locknuts (zinc finish, 10pcs)
TKR1201 – M3 Locknuts (black, 10pcs)
TKR1211 – M3 Locknuts (flanged, black, 10pcs)
TKR1212 – M4 Locknuts (flanged, black, serrated, 10pcs)
TKR1220 – M3 Countersunk Washers (aluminum, natural, 10pcs)
TKR1221 – M3x8mm Washer (black, 10pcs)
TKR1222 – 13x16x1mm Diff Shims (10pcs)
TKR1226 – 5x7x2mm shims (10pcs)
TKR1228 – M4 Countersunk Washer (black, 10pcs)
TKR1235 – Body Clips (10pcs)
TKR1238 – Droop Adjustment Screws (M4x10mm, 8pcs)
TKR1240 – Lower Shock Mount Screws (2 CW thread, 2 CCW thread, EB/NB/SCT)
TKR1248 – M2x4mm Cap Head Screws (black, 10pcs)
TKR1250 – Steering Link Screws (black, steel, 2pcs)
TKR1301 – M2.5x6mm Flat Head Screws (black, 10pcs)
TKR1322 – M3x8mm Flat Head Screws (black, 10pcs)
TKR1324 – M3x12mm Flat Head Screws (black, 10pcs)
TKR1325 – M3x14mm Flat Head Screws (black, 10pcs)
TKR1343 – M4x10mm Flat Head Screws (black, 10pcs)
TKR1344 – M4x12mm Flat Head Screws (black, 10pcs)
TKR1346 – M4x15mm Flat Head Screws (black, 10pcs)
TKR1349 – M4x20mm Flat Head Screws (black, 10pcs)
TKR1401 – M3x6mm Button Head Screws (black, 10pcs)
TKR1402 – M3x8mm Button Head Screws (black, 10pcs)
TKR1403 – M3x10mm Button Head Screws (black, 10pcs)
TKR1407 – M3x16mm Button Head Screws (black, 10pcs)
TKR1443 – M4x10mm Button Head Screws (black, 10pcs)
TKR1444 – M4x12mm Button Head Screws (black, 10pcs)
TKR1445 – M4x14mm Button Head Screws (black, 10pcs)
TKR1523 – M3x10mm Cap Head Screws (black, 10pcs)
TKR1524 – M3x12mm Cap Head Screws (black, 10pcs)
TKR1525 – M3x14mm Cap Head Screws (black, 10pcs)
TKR1528 – M3x18mm Cap Head Screws (black, 10pcs)
TKR1529 – M3x20mm Cap Head Screws (black, 10pcs)
TKR1534 – M3x22mm Cap Head Screws (black, 10pcs)
TKR1601 – M3x4mm Set Screws (black, 10pcs)
TKR1603 – M5x4mm Set Screws (black, 10pcs)
TKR1605 – M3x10mm Set Screws (black, 10pcs)

Option Parts

TKR1103 – Turnbuckle Wrench (4mm, 5mm, hardened steel)
TKR1107 – XT Nut Driver (5.0mm, adjustable length, 4mm shank)
TKR1108 – XT Nut Driver (5.5mm, adjustable length, 4mm shank)
TKR1115 – Pivot Ball and Shock Multi-tool (aluminum)
TKR1116 – 17mm Wheel Wrench, Shock Cap Tool
TKR1119 – 5.5mm / 7.0mm Wrench (hardened steel)
TKR5071B – Wheel Hubs (17mm, alum, ltnd, gun metal ano, 1mm off, w/pins, 2pcs)
TKR5071C – Wheel Hubs (17mm, alum, ltnd, gun metal ano, 2mm off, w/pins, 2pcs)
TKR5071X – Wheel Hubs (aluminum, lightened, gun metal ano, w/pins, 2pcs)
TKR5114XB – Differential Outdrives (front/rear, revised, lightened)
TKR5253B – Aluminum Servo Horn (25t spline, M3 clamp, double hole arm)
TKR6003 – Shock Caps (aluminum, gun metal ano, 2pcs, EB48)
TKR6003B – Shock Caps (aluminum, non-vented top, 2pcs)
TKR6009B – Shock O-Ring Set (16pcs)
TKR6017T – Shock Shafts w/ TiNi coating (rear, steel, 2pcs)
TKR6035 – Shock Spring Set (front, 1.5 x 9.0T, 70mm, pink)
TKR6036 – Shock Spring Set (front, 1.5 x 8.5T, 70mm, green)
TKR6037 – Shock Spring Set (front, 1.5 x 8.0T, 70mm, yellow)
TKR6039 – Shock Spring Set (front, 1.5 x 7.0T, 70mm, red)
TKR6045 – Shock Spring Set (front, 1.5 x 6.5, 5.96lb/in, 70mm, purple)
TKR6160 – Shock Piston Blanks (CNC, flat/tapered, 16 dimples)
TKR6163 – Shock Piston Blanks (CNC, flat/flat, 16 dimples)
TKR6168 – Shock Pistons (CNC, flat/flat, 5x1.6 + 2x1.0)
TKR8292Y – Lightweight Wing (ROAR/IFMAR legal, yellow)
TKR8292K – Lightweight Wing (ROAR/IFMAR legal, black)
TKR8764 – LF Shock Spring Set (front, 1.6x11.0, 3.82lb/in, 75mm, pink)
TKR8765 – LF Shock Spring Set (front, 1.6x10.3, 4.14lb/in, 75mm, green)
TKR8766 – LF Shock Spring Set (front, 1.6x9.7, 4.47lb/in, 75mm, yellow)
TKR8767 – LF Shock Spring Set (front, 1.6x9.0, 4.91lb/in, 75mm, orange)
TKR8768 – LF Shock Spring Set (front, 1.6x8.5, 5.29lb/in, 75mm, red)
TKR8769 – LF Shock Spring Set (front, 1.6x8, 5.73lb/in, 75mm, blue)
TKR8770 – LF Shock Spring Set (front, 1.6x7.75, 5.98lb/in, 75mm, purple)
TKR9040A – Aluminum Rear Hubs (L/R, 7075, gun metal ano, 2.0)
TKR9042 – Spindle Carriers (L/R, 7075, 15 degree, 2.0)
TKR9077 – Brass Weight (15g, NB/NT48 2.0)
TKR9078 – Brass Weight (30g, NB/NT48 2.0)
TKR9080 – Sway Bar (front, 2.0mm)
TKR9081 – Sway Bar (front, 2.1mm)
TKR9082 – Sway Bar (front, 2.2mm)
TKR9084 – Sway Bar (front, 2.4mm)
TKR9085 – Sway Bar (front, 2.5mm)
TKR9086 – Sway Bar (front, 2.6mm)
TKR9087 – Universal Driveshaft Set (f/r, 96.5mm, 2.0, 2 pcs)
TKR9088 – Sway Bar (front, 2.7mm)
TKR9089 – Sway Bar (front, 2.8mm)
TKR9117 – Spur Gear (44t, hardened steel, EB/ET48 2.0)
TKR9174 – Rear Arm Mud Guards (for TKR9184, EB/NB48 2.0)
TKR9181T – Tall Wing Mount (w/ buggy body mounts, 2.0)
TKR9184 – Suspension Arms (rear, EB/NB48 2.0)
TKR9190 – Sway Bar (rear, 2.2mm)
TKR9192 – Sway Bar (rear, 2.3mm)
TKR9193 – Sway Bar (rear, 2.4mm)
TKR9195 – Sway Bar (rear, 2.6mm)
TKR9196 – Sway Bar (rear, 2.7mm)
TKR9197 – Sway Bar (rear, 2.8mm)
TKR9198 – Sway Bar (rear, 2.9mm)
TKR9199 – Sway Bar (rear, 3.0mm)
TKR9268C – Shock Tower (front, carbon fiber, EB/NB48 2.0)
TKR9269 – Shock Tower (rear, 7075 CNC, gun metal ano, EB/NB48 2.0)
TKR9269SC – Shock Tower (rear, short, carbon fiber, EB/NB48 2.0)
TKR9286 – Suspension Arms (front, EB/NB48 2.0)
TKRBB12215 – Ball Bearing (12x21x5, shielded, 4pcs)

Setup Information

The purpose of making adjustments is to make the car go faster around the track, or to make it more controllable, or both if possible. A car that's easier to drive should produce lower, more consistent lap times. It will also inspire more confidence in the driver, which is always good when nerves start getting the best of you.

Before you start thinking about changing your car's setup, consider these two things: First, is the car in perfect working order? Be sure that all of the suspension components operate freely without excessive play, and that the car isn't tweaked. Binding and worn out parts will result in poor performance and inconsistent handling. Second, always consider tires before making other adjustments. Time spent trying to get the vehicle to work with the wrong tires mounted will be wasted time. Without the right tires, even a great setup won't be a winning setup.

Ride Height

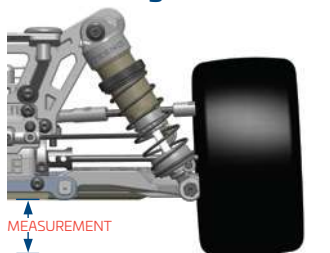

Ride height is the distance from the bottom of the chassis to the running surface. Ride height should only be checked and adjusted when your vehicle is ready to run (i.e. with fuel tank full/body on). Ride height is the first adjustment to be made and should be set with a ride height measurement tool. Measurements should be taken from the flat parts of the chassis, front and rear. Be sure to measure the front ride height at a point before the kick up in the chassis starts. To measure ride height, first make sure the suspension is completely free, then simultaneously compress the front and rear all the way down and let the vehicle settle. Take your measurement from that position. Use the shock spring adjustment collars to raise or lower the ride height to your desired setting. 24mm front and 26mm rear is a good starting point.

Camber

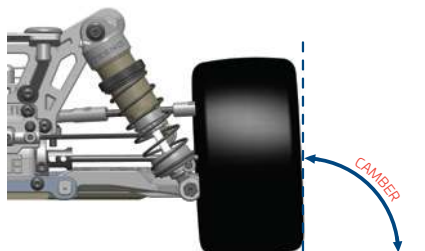

Static camber affects the car's side to side traction. More negative camber front and rear quickens rotation in corners. Less negative camber will make the vehicle easier to drive but you may give up some responsiveness (i.e. steering). To set your static camber have your vehicle at ride height (see above) and adjust the camber links until desired angle is achieved. Please note that a large adjustment of front camber will affect front toe and you may have to readjust the toe and then re-check front camber again. A good starting measurement for camber is 1-2 degrees in the front and 1.5-2.5 degrees in the rear.

Front Toe

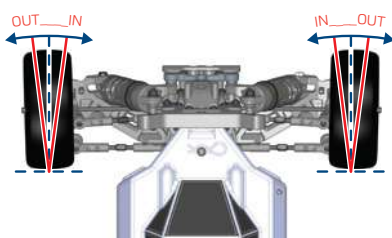

Front toe is used to describe the angle in which the front wheels point when looking down at them from the top of a vehicle. You will always use some amount of toe out. Toe-out will affect how your vehicle enters and exits corners. More toe out will result in more off-power steering and less on-power steering and less toe out will have the opposite results. To set your front toe, have your vehicle at ride height (see above) and adjust the steering links until desired angle is achieved. Please note that a large adjustment of front toe will affect front camber and you may have to readjust the camber and then re-check front toe again. A good starting point is approximately 0.5-1 degree of toe out per side.

Ackermann Effect

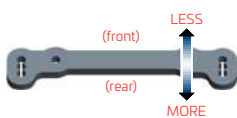

Think of Ackermann as active toe when the steering moves from left to right. More Ackermann effect makes more toe out at full turn and produces more steering off-power. Less Ackermann effect makes less toe out at full turn and produces more steering on-power. A good starting point is the forward hole on the plate.

Bumpsteer



Think of bump steer as active toe when the suspension compresses or rebounds. To adjust bump steer you have to change the angle of the steering link. This is accomplished by adding or removing washers under the ball stud on the steering spindles. Anytime you change camber link locations, front arm pills, front arm spacers, or Ackermann you will need to check and possibly adjust your bumpsteer. It's best to start with zero bumpsteer or slight bump out.

Droop

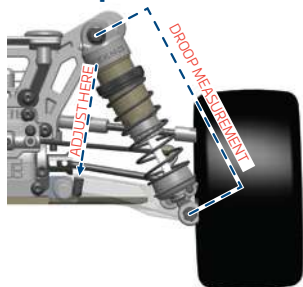

Droop is the measured amount of down travel in the suspension. It is measured from the shock mounting points while the vehicle is up on a stand allowing the arms to hang freely and is adjusted by turning the droop screw located in the suspension arms front/rear. This screw limits the suspension travel by providing a stopping point against the chassis. Left and right sides should always be equal, however the front and rear of the vehicle can have different values. Droop affects all aspects of chassis performance, including braking, acceleration, jumping, traction, and bump handling. A good starting droop measurement is 115mm front, and 121mm rear.

Setup Information

(continued)

Differentials



Front: Changing front diff oil affects overall steering response. Thinner can increase off-power steering but the vehicle may be twitchy and harder to drive. Thicker can increase on power steering and stability. We recommend 10k in the front diff.

Center: Changing center diff oil affects the front-to-rear drive balance. Thicker will reduce off-power steering and on-power rear traction but increases on-power steering and acceleration if traction is available. Thinner will increase off-power steering and on-power rear traction but reduce on-power steering and acceleration. We recommend 10k in the center diff.

Rear: Thinner rear diff oil increases off-power steering and reduces traction into a corner. It also reduces on-power steering and increases traction out of a corner. Going too thin will make your vehicle inconsistent, however. Thicker rear oil will have opposite effects, and once again, going too thick will make the vehicle inconsistent. We recommend 7k in the rear diff.

Wheelbase Adjustments

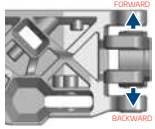

Changes to wheelbase can affect the overall handling of your vehicle, since it adjusts the distribution of weight on the wheels as well as the angle of the driveshafts. Shortening the wheelbase at

the rear will give you more steering into a turn and off power, less steering out of a turn and on power. Lengthening the wheelbase at the rear will yield the opposite results. In general a longer wheelbase is better on open and/or bumpy tracks and a shorter wheelbase is better on tighter technical tracks.

Active Toe

Active rear toe is essentially bump steer for the rear suspension. It affects the vehicle anytime it is accelerating, cornering, braking, jumping, or going through bumps. There are two types of active toe, in or out depending on which direction the active toe inserts are installed. When using active toe in (C or D arm inserts upside down), the rear tires will "toe in" more during suspension compression and "toe out" during suspension droop. The opposite happens when using active toe out (C or D arm inserts right side up). When using the **active toe in** setting, the vehicle will be more locked in during acceleration at the rear end and possibly have a push during corner exit. It will have more rear grip through the corner, but possibly not as fast through the corner. It will be looser in the rear under braking and possibly have more steering, but will hold it's line off of jumps better, although may have too much rear traction during the landing. It will accelerate through bumps better, but could catch ruts more easily. When using the **active toe out** setting, the vehicle will be looser during acceleration and have more steering, but will have less rear grip

through the corner. It will have more overall speed, but will have less steering under braking, and will be less precise during jump takeoff, although it will be more forgiving during jump landing. It will be very smooth and forgiving through the bumps but will lack some grip. If you are using the inserts that also add 1 degree of static toe in (D arm inserts), You may want to remove 1 degree of toe in from the hinge pin blocks, to achieve the same overall amount of static toe in. When doing this, you will remove some angle from the rear driveshafts. This will create similar results as the **active toe out** inserts (better in bumps, quicker cornering, etc.), but to a lesser degree.

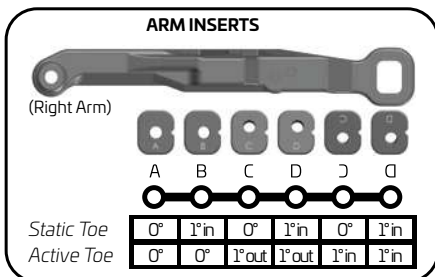

Hub Inserts

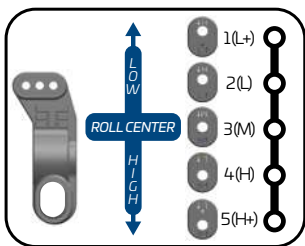

By changing the rear hub inserts you can alter the rear roll center of the vehicle. These hub inserts will also affect axle height, uptravel, and downtravel (droop) values. It is important to note that with any hub insert change you will have to check and possibly change other settings on the car. When running a higher roll center (higher number inserts) you will need to limit your uptravel with o-rings on the shock shaft, outside of the shock body and possibly increase the amount of droop you're running. When running a lower roll center (lower number inserts) you will need to remove o-rings from the shock shaft to increase up travel, and may need to decrease the amount of droop you're running. When changing the inserts the rear camber link location on the tower will also need to be adjusted to maintain your current link to arm angle. When going to a lower roll center (lower number insert) you will need to move the camber link down on the tower. When going to a higher roll center (higher number insert) you will need to move the link up on the tower. A lower number insert will provide more roll and typically give more off power

rear traction and less on power rear traction. The car will change directions more slowly, roll deeper into turns, and can be more forgiving off power or under braking but more aggressive under acceleration. A higher number insert will provide less roll and typically give less off power rear traction and more on power rear traction. The car will change directions more quickly and can be more aggressive off power or under braking but more forgiving under acceleration.

Springs

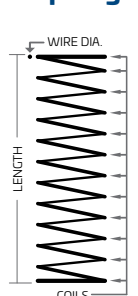

Standard Frequency

PART#/COLOR	WIRE DIA	COILS	LENGTH	RATE
TKR6035	15	900	70mm	3.83
TKR6036	15	850	70mm	4.15
TKR6037	15	800	70mm	4.47
TKR6038	15	750	70mm	4.92
TKR6039	15	700	70mm	5.36
TKR6040	15	675	70mm	5.65
TKR6045	15	650	70mm	5.96

Low Frequency

PART#/COLOR	WIRE DIA	COILS	LENGTH	RATE
TKR8764	16	1100	75mm	3.82
TKR8765	16	1025	75mm	4.14
TKR8766	16	975	75mm	4.47
TKR8767	16	900	75mm	4.91
TKR8768	16	850	75mm	5.29
TKR8769	16	800	75mm	5.73
TKR8770	16	750	75mm	5.98

Softer springs will increase traction through the turns by allowing more roll, slow down the responsiveness of the vehicle, and can be better in the bumps. Stiffer springs will increase corner speed if traction is available and will also tend to jump and land better. Once you find a set of springs you like you will typically only change them for tracks with dramatically different conditions. LF springs reduce chassis oscillations by having less rebound and being more linear than our standard springs.

Pistons



Pistons with smaller holes work well for smoother tracks with large jumps and

pistons with larger holes work well for rougher tracks with less jumps. Smaller hole pistons will typically use thinner oil than larger hole pistons. Shock oil is also affected by the ambient temperature so a change in viscosity might be necessary with a change of 5°C or ~10°F.

Sway Bars



Sway bars are used to adjust a vehicle's lateral grip by resisting chassis roll. A thicker bar decreases roll more than a thinner bar will. More roll means more grip and less roll means less grip. The front sway bar affects mainly off-power steering at corner entry. The rear sway bar affects mainly on-power steering and stability in mid-corner and at corner exit.

Maintenance:

Performing regular maintenance will greatly improve your on track consistency and also extend the life of your vehicle. Going through critical areas of the vehicle regularly will also allow you to find possible issues before they become a problem that may cost you a race. Follow the guidelines below for maximum performance.

Bearing Maintenance:

Bearings should always be smooth and free in order to perform their function. We recommend inspecting and cleaning each bearing on a regular basis. It will be necessary to break down parts of the vehicle in order to inspect them properly. The procedures below should be done every couple of weeks or prior to an important race.

1. Inspect the outer seals for any visible damage and check the rolling resistance of each bearing.
2. If any bearing does not spin freely, then take the following steps to clean them.
3. Spray the bearing with motor spray and spin it again to remove any debris trapped inside. Repeat if necessary. If the bearing does not start to spin freely after cleaning, then they may need to be replaced.
4. Allow the clean bearing to dry or blow into the bearing with compressed air to speed up the drying process.
5. Oil each bearing with a proper bearing lubricant. One or two drops is enough.

Shock Maintenance:

When comparing the left and right shocks of the front end, they should feel identical. Same goes for the rears. The procedures below should be done every race day to make sure they are leak free and operating correctly.

1. After removing the shocks from the vehicle, remove the springs and inspect each shock for visible leaks (build up of debris at the bottom of the shock shaft or visible oil).
2. If the shock binds when pushing the shaft through its stroke, then the shaft may be bent and will need to be replaced.
3. If the shocks from left to right do not feel consistent when compared to each other, or have built up too much air inside (feel empty when pushing the shaft through its stroke), then you will need to rebuild them following the steps outlined on page 19 of this manual.

Hinge Point & Drive Line Maintenance:

Checking the hinge points while the shocks are removed from the vehicle is the best time to inspect these parts. The other items to inspect are the camber links, steering links and drive shafts. Follow the steps below every couple of weeks in order to keep the vehicle performing at the maximum level.

1. With the shocks off the vehicle, check the movement of the arms, hubs, and spindle carriers. They should move freely. If there is a bind, then the inner or outer hinge pin may be bent and would need to be replaced. The arms should not have any play when twisted or moved in any direction against the hinge points. If there is excessive slop present, then the arms or hubs may be worn and will need to be replaced.
2. Remove the camber links, steering links and servo link from the vehicle. Check the movement of the spindles to see if they turn freely. If they don't, then check the kingpin shoulder screws to see if they are tightened down too far. Also, check for slop. If there is excessive slop present, then the spindle carriers may need to be replaced.
3. Check the steering rack to make sure it moves freely. If it binds, then the screws holding the Ackermann or the steering posts could be too tight. If they still bind, then check the bearings and follow the steps above to clean them.
4. After re-installing the camber links, steering links and servo link, check the movement of the rod ends on the ball studs. If they have excessive slop or are binding, then they may need to be replaced.
5. Check the drive shafts by rotating them. Look for any wobbles. If they are bent, replace them immediately.
6. With the drive shafts removed, check for slop in the CV area. If it is present, then reposition the CV pin to another fresh hole, re-lubricate and install back into the vehicle.

Differential Maintenance:

Properly maintained differentials are essential for a smooth operating vehicle. Check all three diffs regularly to make sure they are filled and operating as designed.

1. Remove each diff and verify the differential action is happening and is smooth. If there is any notchy feel to them, follow the steps below to rebuild them.
2. Open the diff and pour out the oil. Remove the gears and pins to release the outdrives, then remove the seals. Inspect everything to make sure there are no damaged parts. If the seals are old or show any signs of degradation, replace them immediately. Re-lubricate the seals and outdrives, then rebuild the diff following the steps on page 3 and 4.

Name: Box Stock

Date: _____

Event: _____

Track: INDOOR OUTDOOR Size: SMALL MEDIUM LARGE Traction: LOW MEDIUM HIGH

Surface: SMOOTH BUMPY RUTTED Type: LOOSE / LOAMY HARD PACKED BLUE GROOVE CLAY ASTRO

Bumpsteer/Ackerman/Servo Saver/Steering Stop: _____ Condition: DUSTY DRY WET MUDDY

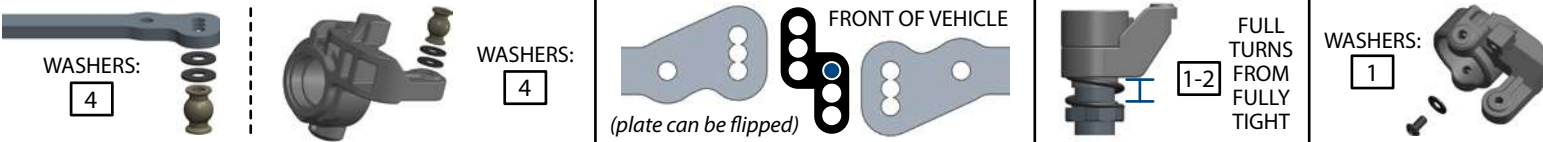

Front End:

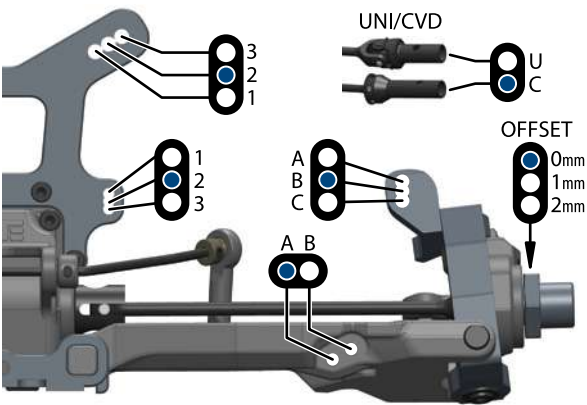

"A" Block:
(Arm Sweep)
(0° with center dot inserts)

"B" Block:
(Kick-Up)
(10° with center dot inserts)

Suspension:

RIDE HEIGHT: **24** CAMBER: **-2°**
 CASTER BLOCK: **18°** SWEEP: **0°**
 KICK UP: **11°** TOE: **1° out**
 SWAY BAR: **2.3mm** DROOP: **115mm**

Shocks:

OIL: **650 CST** BRAND: **Kit**
 PISTON: **5x1.5 + 2x1.0** SPRING: **TKR6040**
 REBOUND: **0%** BUILD: **emul**

Differential Oil:

FRONT	CENTER	REAR
10k	/ 10k	/ 7k
Drivetrain:		
PINION / SPUR: 16	/ 44	(teeth)

Equipment:

ESC: _____
 BATTERY: _____
 MOTOR: _____
 SERVO: **300oz min**

Chassis Braces:

CENTER DIFF: REAR:
 BATTERY INNER: BATTERY OUTER:

Tires / Wheels:

BRAND / TREAD: _____
 COMPOUND: _____
 INSERT: _____
 WHEEL: _____
 NOTES: _____

Body / Wing:

BODY MAKE: **stock**
 WING MAKE: **stock**

Notes:

Rear End:

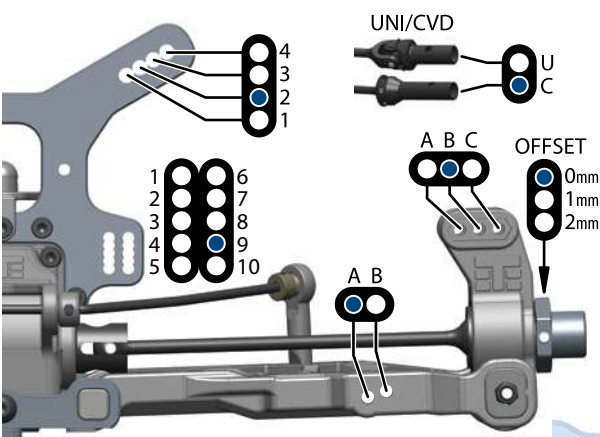

"C" Block:
(Anti-Squat)
(1° with center dot inserts)

"D" Block:
(Rear Toe)
(2.5° with center dot inserts)

Suspension:

RIDE HEIGHT: **26** CAMBER: **-2°**
 ANTI-SQUAT: **1.5°** TOE: **3°**
 SWAY BAR: **2.5mm** DROOP: **121mm**

Shocks:

OIL: **600 CST** BRAND: **Kit**
 PISTON: **5x1.5 + 2x1.0** SPRING: **TKR6038**
 REBOUND: **0%** BUILD: **emul**

Rear Hub / Wheelbase:

(Roll Center)

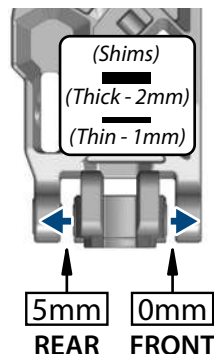
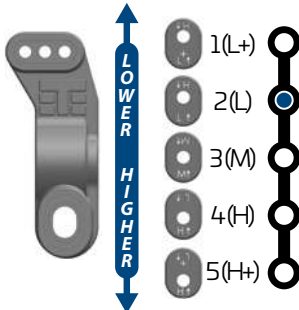

Arm Inserts:

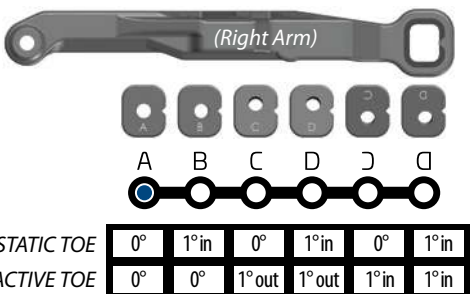

Name: _____ Date: _____ Event: _____

Track: INDOOR OUTDOOR Size: SMALL MEDIUM LARGE Traction: LOW MEDIUM HIGH

Surface: SMOOTH BUMPY RUTTED Type: LOOSE / LOAMY HARD PACKED BLUE GROOVE CLAY ASTRO

Bumpsteer/Ackerman/Servo Saver/Steering Stop: _____ Condition: DUSTY DRY WET MUDDY

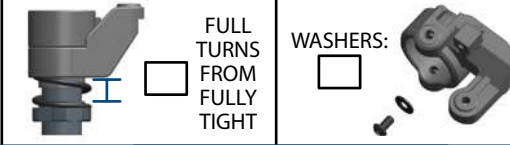
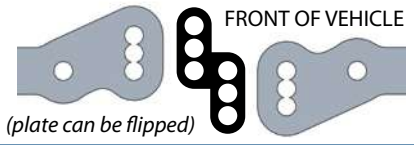

Front End:

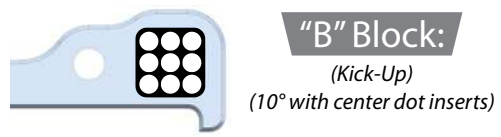
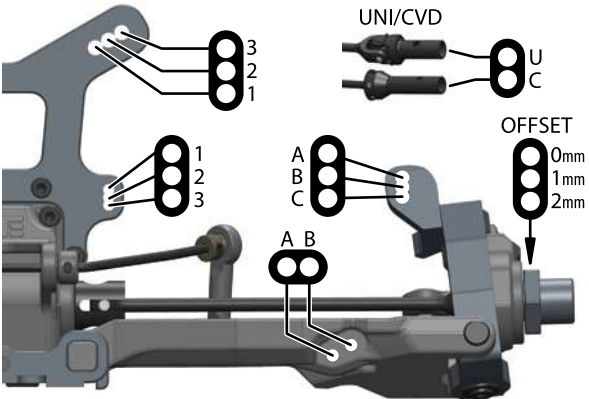

Suspension:

RIDE HEIGHT: _____ CAMBER: _____
 CASTER BLOCK: _____ SWEEP: _____
 KICK UP: _____ TOE: _____
 SWAY BAR: _____ DROOP: _____

Shocks:

OIL: _____ BRAND: _____
 PISTON: _____ SPRING: _____
 REBOUND: _____ BUILD: _____

Differential Oil:

FRONT	CENTER	REAR
/	/	/
Drivetrain:		
PINION / SPUR: _____		(teeth)
Equipment:		

ESC: _____
 BATTERY: _____
 MOTOR: _____
 SERVO: _____

Chassis Braces:

CENTER DIFF: REAR:
 BATTERY INNER: BATTERY OUTER:

Tires / Wheels:

BRAND / TREAD: _____
 COMPOUND: _____
 INSERT: _____
 WHEEL: _____
 NOTES: _____

Body / Wing:

BODY MAKE: _____
 WING MAKE: _____

Notes:

Rear End:

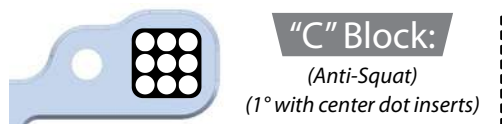
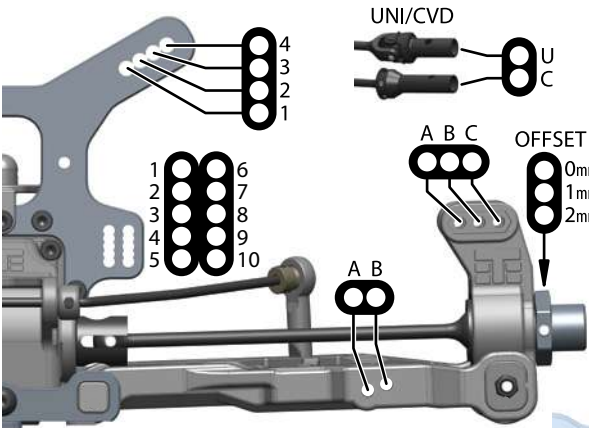

Suspension:

RIDE HEIGHT: _____ CAMBER: _____
 ANTI-SQUAT: _____ TOE: _____
 SWAY BAR: _____ DROOP: _____

Shocks:

OIL: _____ BRAND: _____
 PISTON: _____ SPRING: _____
 REBOUND: _____ BUILD: _____

Arm Inserts:

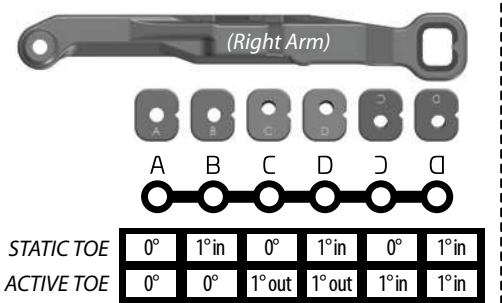

Rear Hub / Wheelbase:

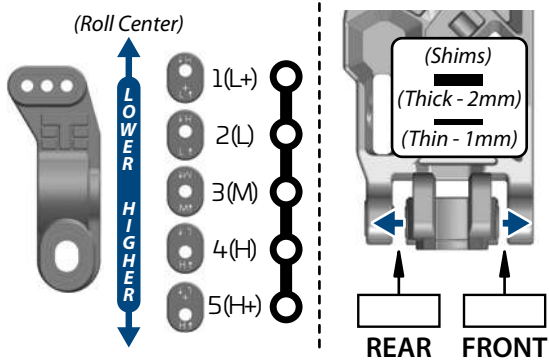

Radio Information

Please read thoroughly

The Tekno RC EB48 2.0 is built out of the box with a neutral setup but is highly tunable to your individual driving needs. Before you start changing your setup on the car itself, it's best to ensure you're getting the best setup out of your radio. It's easy to forget that a lot of simple tuning can be done right from your controller. To help with this, we recommend that you are well informed about setting up your Steering End Points (EPA), Dual Rate (D/R), Exponential Curves, and Servo Speed.

Start by setting your steering EPA such that the vehicle can reach 'full lock' while on the ground. Be careful not to go too far with this setting as it may damage your servo. Drive the vehicle around the track. If you are turning into pipes or losing traction out of a corner, you probably have too much overall steering throw. The simplest way to reduce this is with Dual Rate. Reducing Dual Rate will turn down both the left and right side EPA proportionately without having to adjust the EPA settings independently. D/R is usually pre-assigned to one of the trim buttons on most mid-to-high level radios.

The next setting is 'Expo' or 'Curve'. Expo does not change your EPA or D/R, it simply turns the wheels less around center and ramps up to the end points as you reach full lock on the steering wheel. We would suggest starting at -10%. If your vehicle still feels "twitchy" around center, dial in more negative expo to continue smoothing everything out. If it starts to feel too numb around center, dial some out.

Another valuable and often overlooked radio adjustment is "Servo Speed". Servo Speed allows you to slow the steering servo down from the transmitter resulting in reduced twitchiness. We like to set this at around -10 to start. If you find that it's too lazy, increase the servo speed slightly and run a few more laps. Repeat as necessary until the steering response feels natural without delay.

After setting the servo speed you might find that you need to go back and adjust the expo setting. This is normal, it might take a few adjustments of each to achieve the proper steering "feel" to suit your driving style and track conditions.

The last setting to look at would be your brake end point or brake dual rate. Having brakes set correctly, can gain you tenths on the track and improve your consistency. Start by calibrating your ESC with your throttle/brake end points at 100%. Once on the track, try turning the brake end point/dual rate down to 80%. Under maximum braking you'll want your tires to be as close as possible to locking up without them actually doing it. Keep adjusting the setting up or down until you find the spot that works best. Keep in mind that this setting will change from track to track and even throughout the day as conditions will vary. (Be aware this setting will also affect your maximum reverse speed if you are using reverse.)

With these five settings, you should be able to make your vehicle more consistent and easier to drive, lap after lap, assuming the rest of the vehicle setup is close for your particular track. Of course there are many other factors and setup options to tune on your vehicle, but sometimes all you need is a small radio adjustment to keep you headed in the right direction.

Notes:



Tekno RC
10755 Scripps Poway Pkwy #598
San Diego CA 92131
USA

www.teknorc.com
info@teknorc.com

EB48 2.0