



BUILDING  
INSTRUCTIONS



# INTRODUCTION



Thank you for purchasing the Tekno RC EB48.4 1/8th Scale 4WD Competition Electric Buggy Kit. We are always working on new projects, so please check our website at [www.teknorc.com](http://www.teknorc.com) or our Facebook page at [www.facebook.com/teknorc](http://www.facebook.com/teknorc) regularly for the latest news, parts, and kits.

Take your time! When you work your way through these building instructions, keep an eye out for the following important indicators below:

- **RED TEXT** - *This indicates important areas of the build process that should be observed.*



### Thread Lock icons

*Thread lock is always used when a screw is inserted into any metal part. (Included with kit)*



### Grease icons

*Grease is usually used on areas with movement and for sealing. (Included with kit)*

- **YOUTUBE** - *We also have many useful build videos on Youtube, so be sure to check these out!*  
<https://www.youtube.com/c/teknorc>

### Additional equipment and parts needed:

- Paint for body
- 1/8th scale ESC and motor system
- High torque steering servo (at least 300 oz/in)
- 4s (4 cell, 14.8v) LiPo battery (at least 5000mAh)
- 1/8th scale tires, wheels & CA glue (or premounts)
- MOD1 Pinion 15 tooth - 25 tooth (TKR4175 - TKR4185)

### Tools needed:

- Hex drivers 1.5mm (TKR1104), 2.0mm (TKR1105), 2.5mm (TKR1106)
- Nut drivers 5.0mm (TKR1107), 5.5mm (TKR1108), 7.0mm (TKR1109)
- Hobby knife
- Needle-nose pliers
- Shock tool (TKR1115) OR adjustable (Crescent) wrench (for shock assembly)
- 17mm Wheel Wrench (TKR1116)
- 4mm turnbuckle wrench (TKR1103) - 5.5/7.0 two sided wrench (TKR1119)
- 4mm arm reamer (or #19 drill bit)

**Disclaimer:** Tekno RC is not responsible or liable for any property or personal damage, loss, or injury incurred as a result of using this product. This kit is meant for use by persons 14 years of age or older and in the strict confines of a legally permitted RC track or facility.

**Warnings:** Always double-check that your radio gear is working properly before operating vehicle. Never operate the vehicle indoors (unless the RC track is an indoor facility). Use caution while operating vehicle so as not to collide with people who may be turn marshalling or who might otherwise not be aware that a fast moving RC vehicle is in the vicinity.

**Warranty:** We warrant that the parts included in this kit are free from defects. If you find a defective part in your kit, please contact us @ [info@teknorc.com](mailto:info@teknorc.com) and we will help you to resolve the issue. We do not warranty parts that may be broken during operation of the vehicle or otherwise. Refer to the end of this instruction manual for a listing of spare/replacement and option parts. All spare parts and other info are available on our website ([www.teknorc.com](http://www.teknorc.com)) and through our network of domestic and international dealers and distributors.

# BAG A

## CENTER DIFFERENTIAL

### (OVERVIEW)

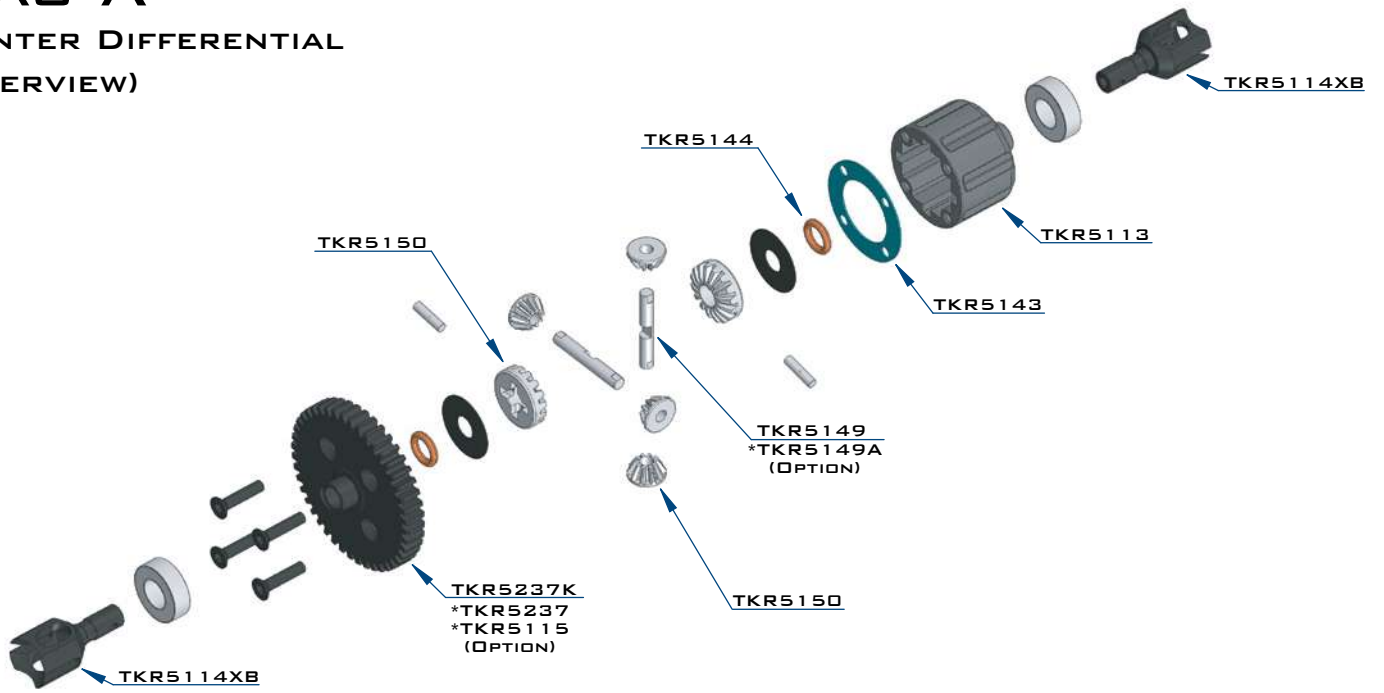

#### STEP A-1

Apply grease to the groove where the o-ring is placed as well as the o-ring itself

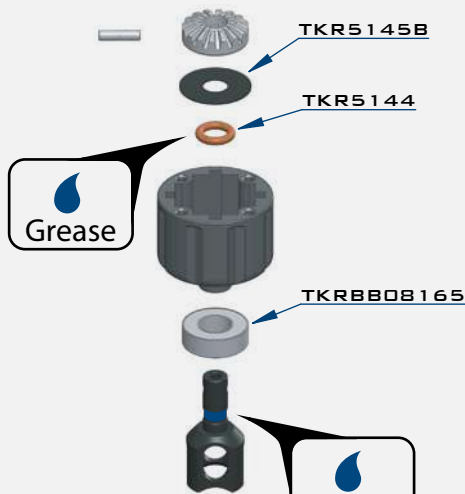

Apply grease to the groove in the outdrive

#### STEP A-2

TKR5149 \*TKR5149A (OPTION)

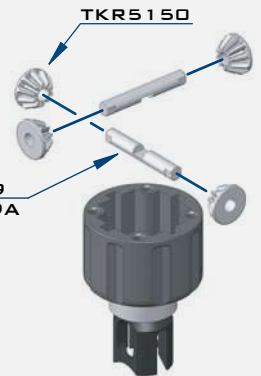

#### STEP A-4

Apply grease to the groove in the outdrive

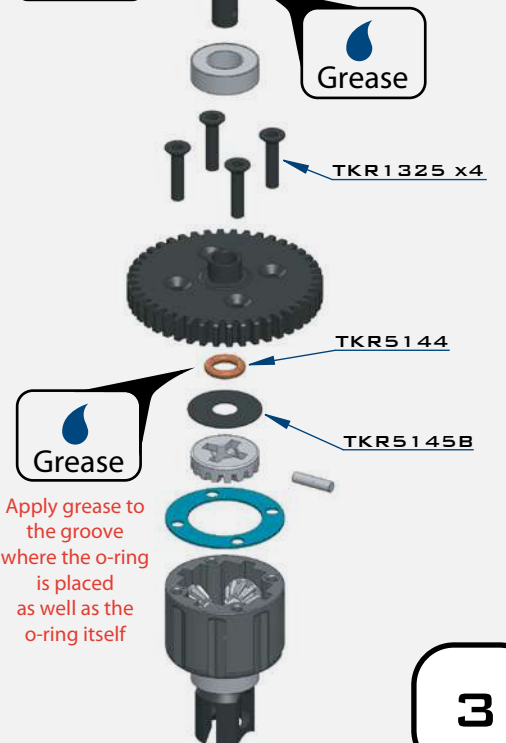

Apply grease to the groove where the o-ring is placed as well as the o-ring itself



TKR1325  
M3X14MM FLAT HEAD SCREW



TKR5144  
DIFFERENTIAL O-RINGS

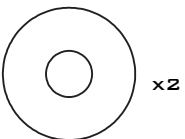

TKR5145B  
DIFFERENTIAL SHIMS (6X17MM)



TKRBB08165  
BALL BEARING (8X16X5MM)

#### STEP A-3

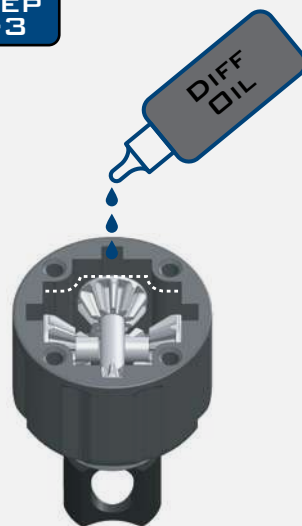

Fill with 10,000 wt oil to 1mm below full  
DO NOT OVERFILL

# BAG B

## FRONT AND REAR DIFFERENTIAL (OVERVIEW)

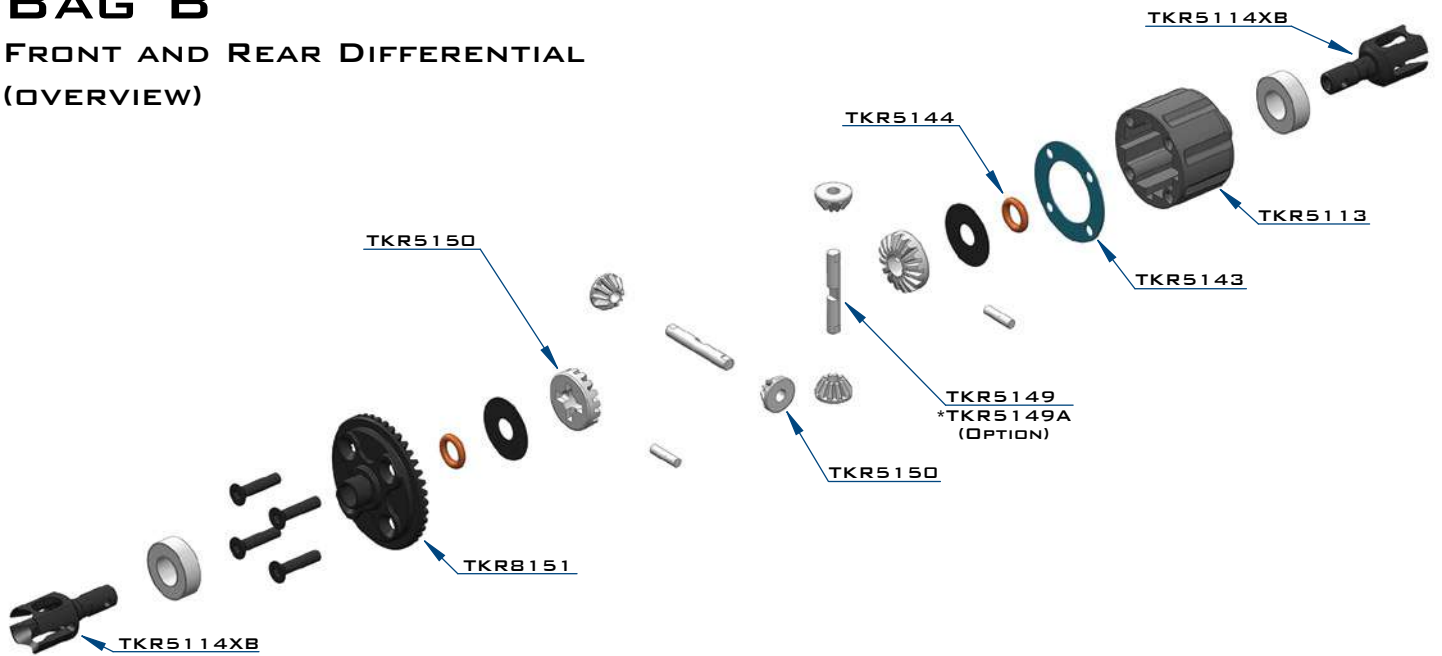

### STEP B-1

Repeat for rear diff

Apply grease to the groove where the o-ring is placed as well as the o-ring itself

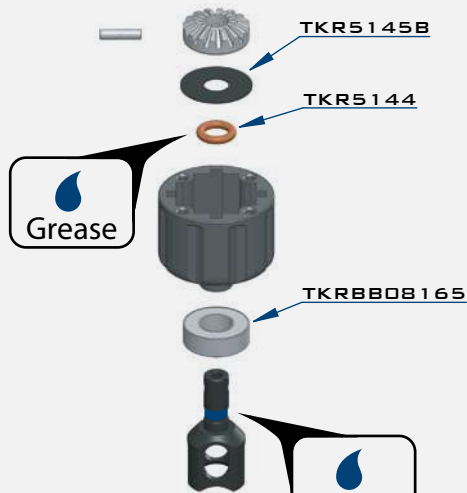

Apply grease to the groove in the outdrive

### STEP B-2

Repeat for rear diff

TKR5149  
\*TKR5149A (OPTION)

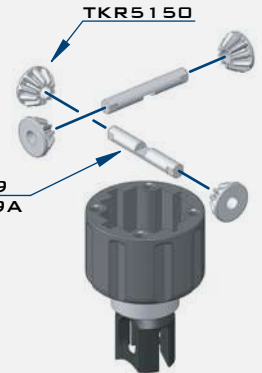

### STEP B-4

Repeat for rear diff

Apply grease to the groove in the outdrive

Apply grease to the groove where the o-ring is placed as well as the o-ring itself



### STEP B-3

Repeat for rear diff



Fill FRONT with 10,000 wt oil  
Fill REAR with 7,000 wt oil  
to 1mm below full  
DO NOT OVERFILL



TKR1325  
M3X14MM FLAT HEAD SCREW



TKR5144  
DIFFERENTIAL O-RINGS

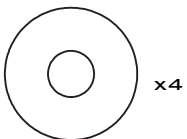

TKR5145B  
DIFFERENTIAL SHIMS (6X17MM)



TKRBB08165  
BALL BEARING (8X16X5MM)

# BAG C

## FRONT GEARBOX (OVERVIEW)

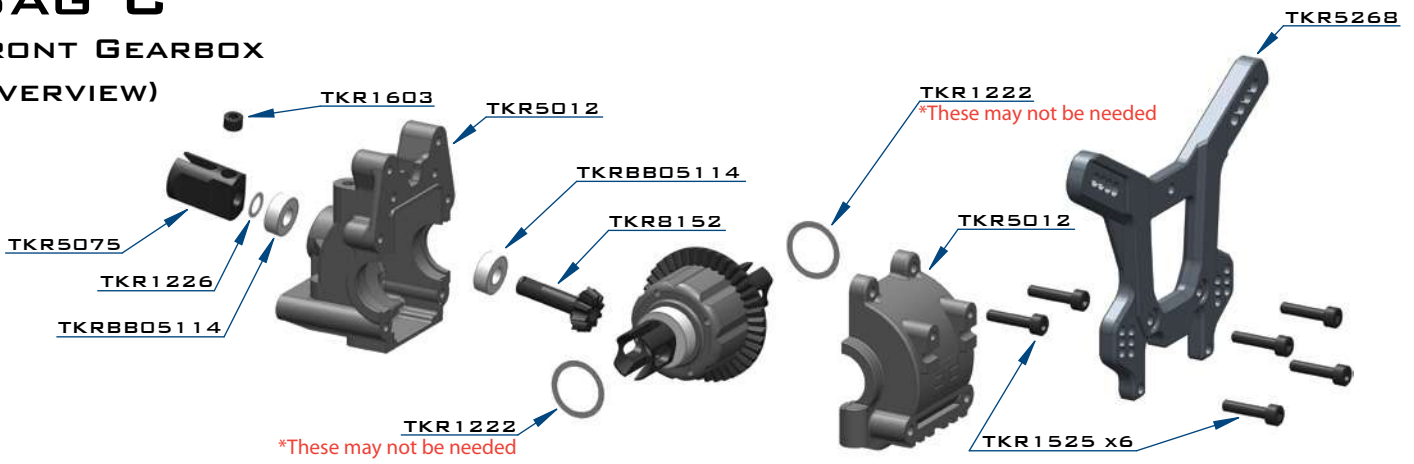

### STEP C-1

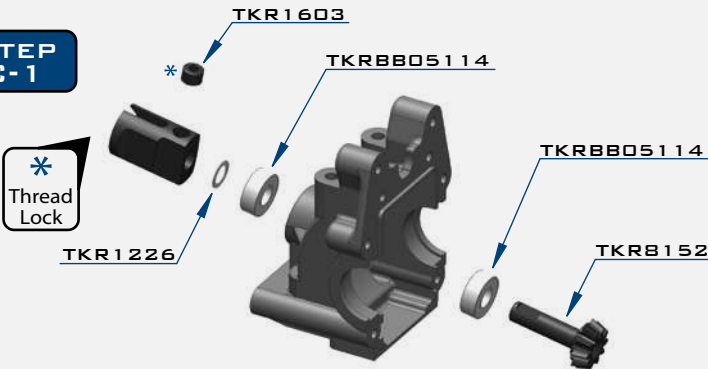

### INNER BULKHEADS

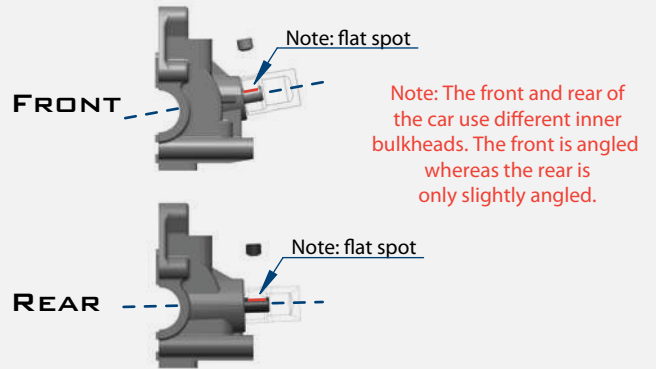

Note Step C-2: To properly shim the diff, start by test fitting the diff with no shims and check for side to side play. If no (or very little) play is present, then continue on to the next step. If you feel excessive side to side play, then start by adding one shim on the gear side of the diff assembly. This will move the mesh tighter and remove any play. If the mesh is too tight at this point, move the shim to the other side. In some rare cases, two shims may be necessary.

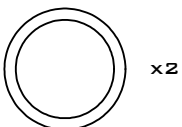

x2  
TKR1222  
13X16XD.1MM DIFF SHIM



x1  
TKR1226  
5X7XD.2MM SHIM

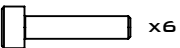

x6  
TKR1525  
M3X14MM CAP HEAD SCREW



x1  
TKR1603  
M5X4MM SET SCREW



x2  
TKRBB05114  
BALL BEARING (5X11X4)

### STEP C-2

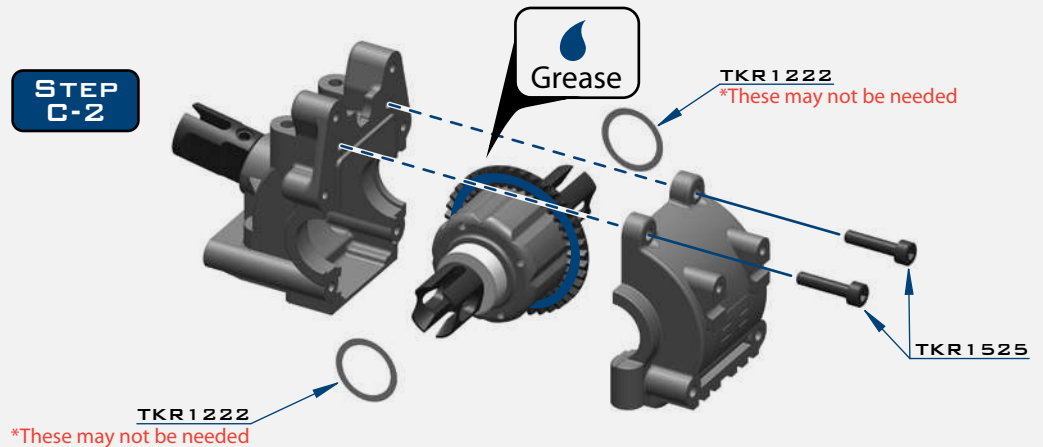

### STEP C-3



# BAG D

## REAR GEARBOX (OVERVIEW)

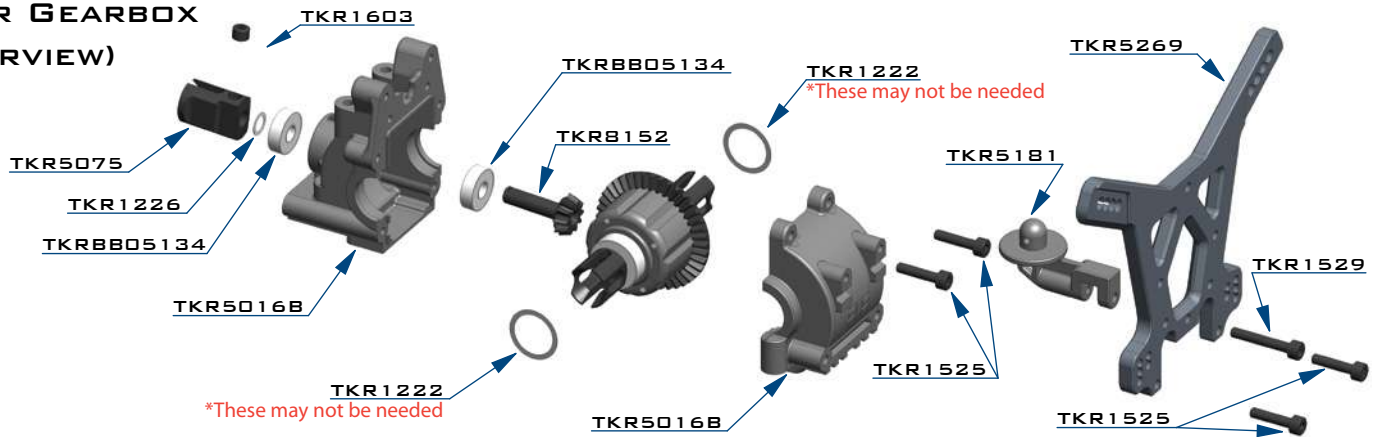

### STEP D-1

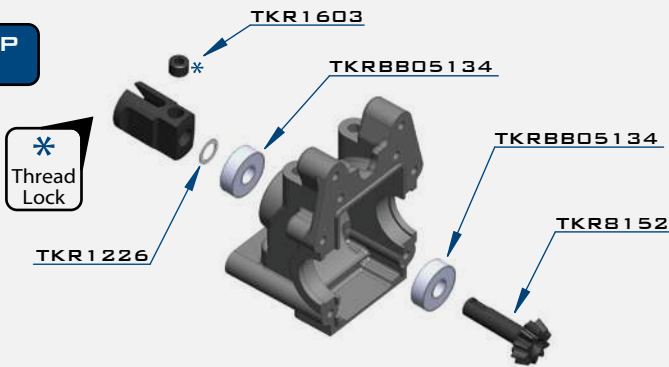

### INNER BULKHEADS

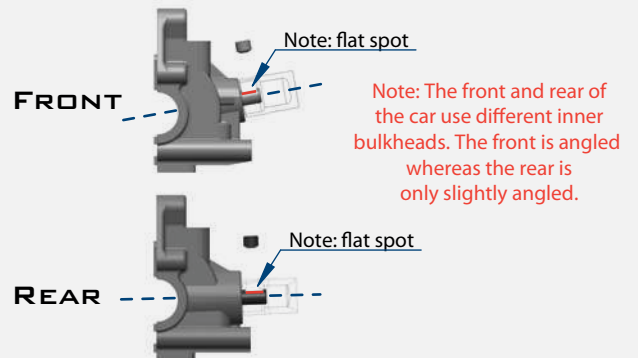

Note Step D-2: To properly shim the diff, start by test fitting the diff with no shims and check for side to side play. If no (or very little) play is present, then continue on to the next step. If you feel excessive side to side play, then start by adding one shim on the gear side of the diff assembly. This will move the mesh tighter and remove any play. If the mesh is too tight at this point, move the shim to the other side. In some rare cases, two shims may be necessary.

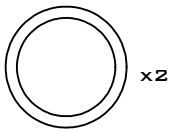

TKR1222  
13X16X0.1MM DIFF SHIM

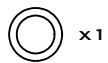

TKR1226  
5X7X0.2MM SHIM

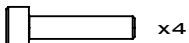

TKR1525  
M3X14MM CAP HEAD SCREW

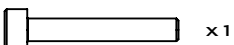

TKR1529  
M3X20MM CAP HEAD SCREW



TKR1603  
M5X4MM SET SCREW

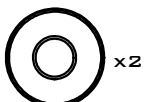

TKRBB05134  
BALL BEARING (5X13X4)

### STEP D-2

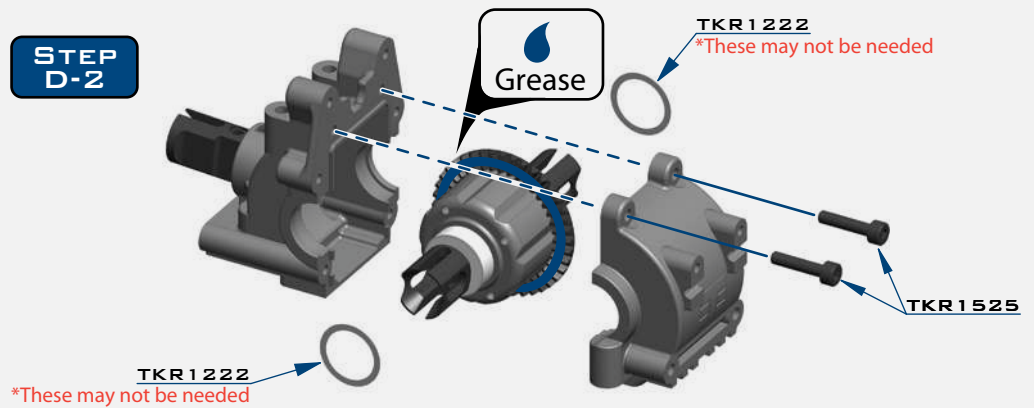

### STEP D-3

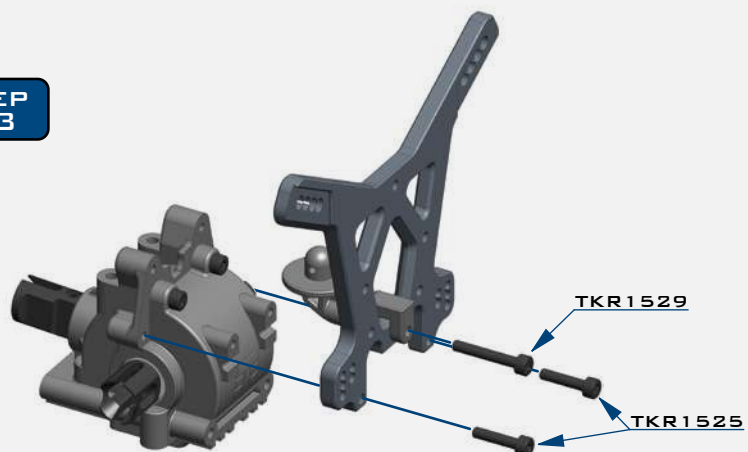

# BAG E

## LOW PROFILE WING MOUNT

### SETTINGS

#### POSITION SETTINGS

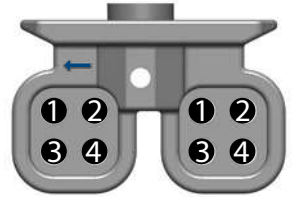

- 1 - REARWARD LOW
- 2 - FORWARD LOW
- 3 - REARWARD HIGH
- 4 - FORWARD HIGH

Note: Stock position setting is #2, Forward Low

#### DOWNFORCE SETTINGS

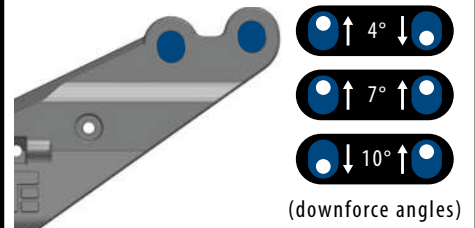

(downforce angles)

Note: Stock downforce setting is 4°

### STEP E-1

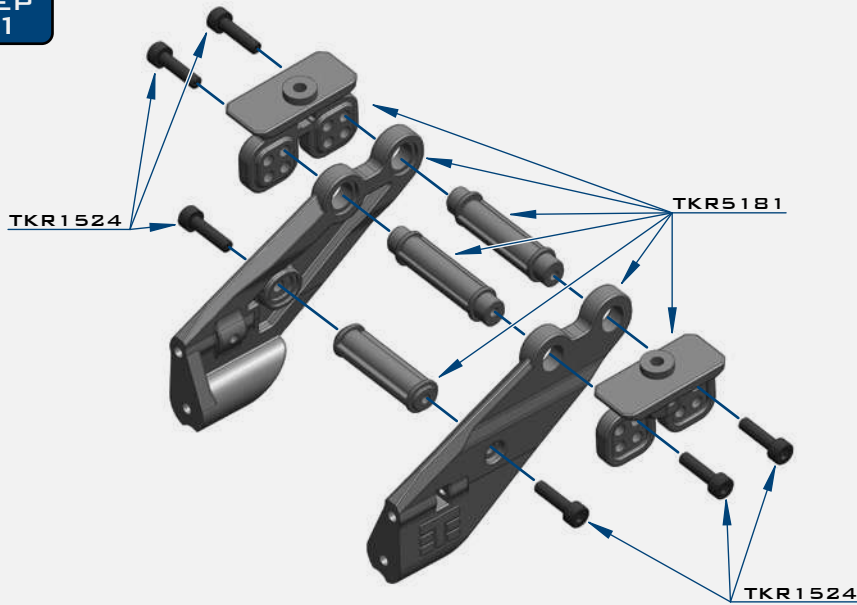

### STEP E-2

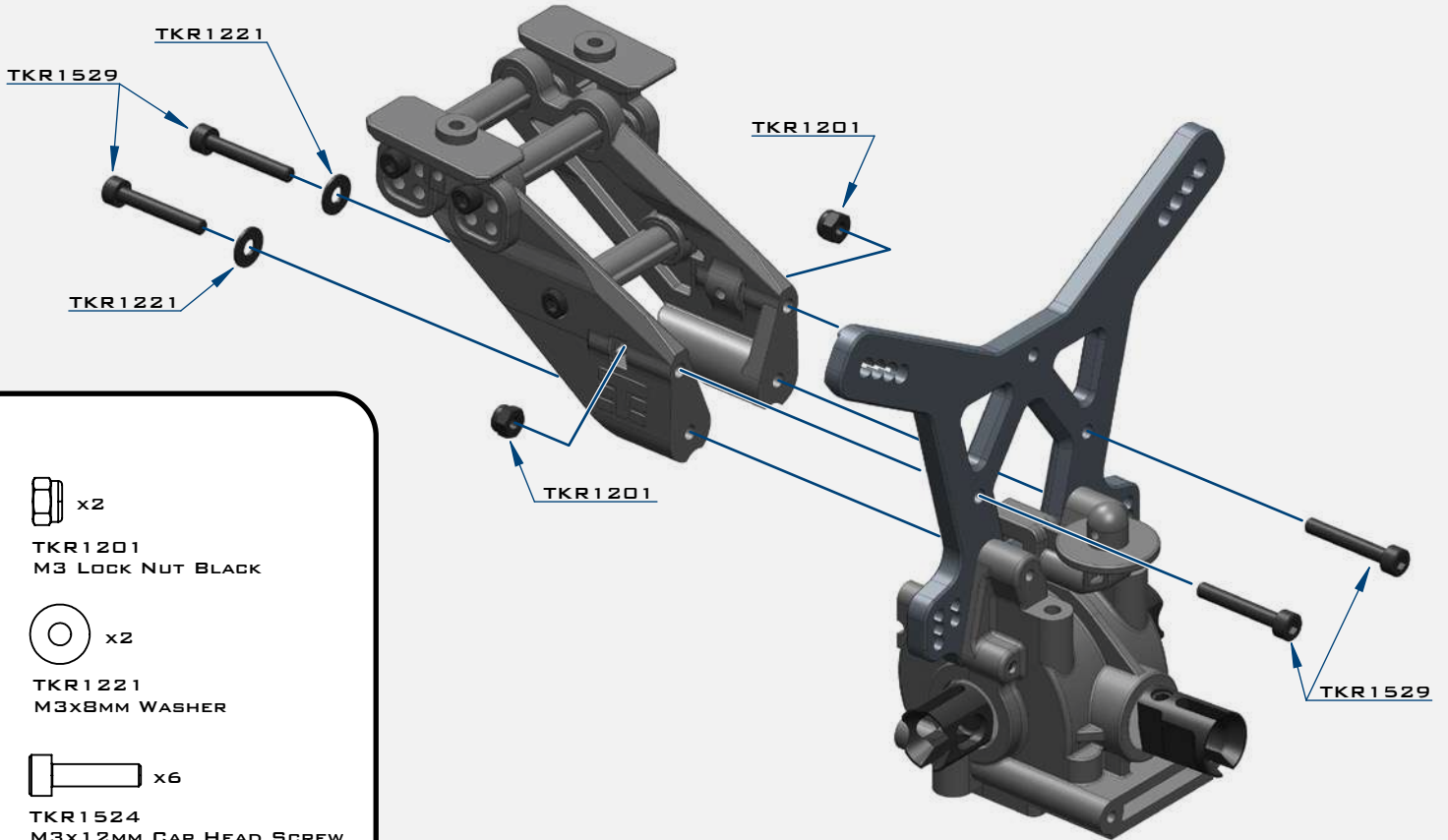

x2

TKR1201  
M3 LOCK NUT BLACK



x2

TKR1221  
M3X8MM WASHER

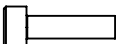

x6

TKR1524  
M3X12MM CAP HEAD SCREW

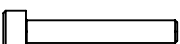

x4

TKR1529  
M3X20MM CAP HEAD SCREW

# BAG F

## REAR END

### STEP F-1

- TKR5491 - 2.4MM
- \*TKR5490 - 2.3MM
- \*TKR5492 - 2.5MM
- \*TKR5493 - 2.6MM
- \*TKR5494 - 2.8MM
- \*TKR5495 - 3.0MM (OPTION)

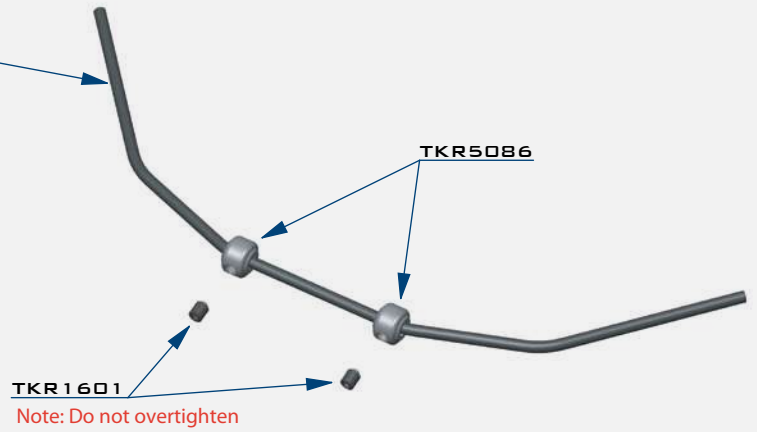
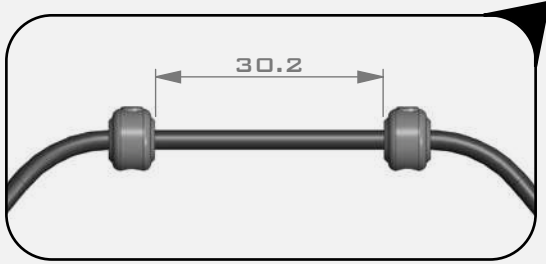

### STEP F-2

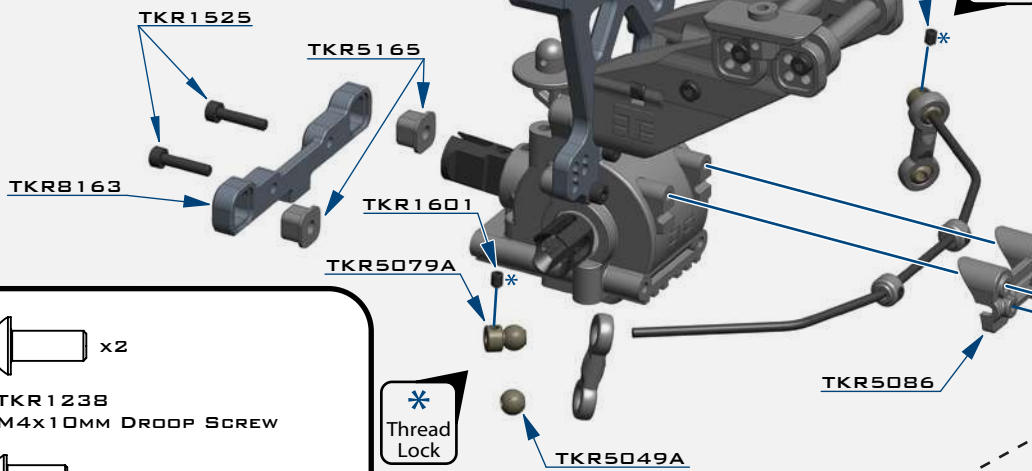

#### Pivot Ball Orientation

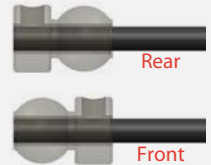

Install the sway bar ball onto the sway bar wire until the end of the wire is flush with the ball collar as pictured above.

#### ("C" Block)



Note: Loosen the M3x4 set screw (TKR1601) if the sway bar does not turn freely.

#### ("D" Block)



Note: With these stock settings, Anti-Squat = 2° / Rear Toe = 2.5°  
For reference, with center dot inserts in both braces, Toe = 3° / Anti-Squat = 2°

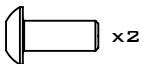

TKR1238  
M4x10MM DROOP SCREW

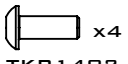

TKR1402  
M3x8MM BUTTON HEAD SCREW



TKR1522  
M3x8MM CAP HEAD SCREW

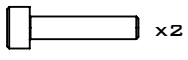

TKR1525  
M3x14MM CAP HEAD SCREW

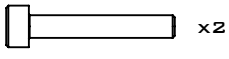

TKR1529  
M3x20MM CAP HEAD SCREW

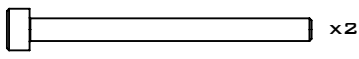

TKR1533  
M3x40MM CAP HEAD SCREW



TKR1601  
M3x4MM SET SCREW



TKR5049A  
PIVOT BALL SWAY BAR

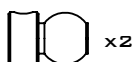

TKR5079A  
STABILIZER BALL

### STEP F-3

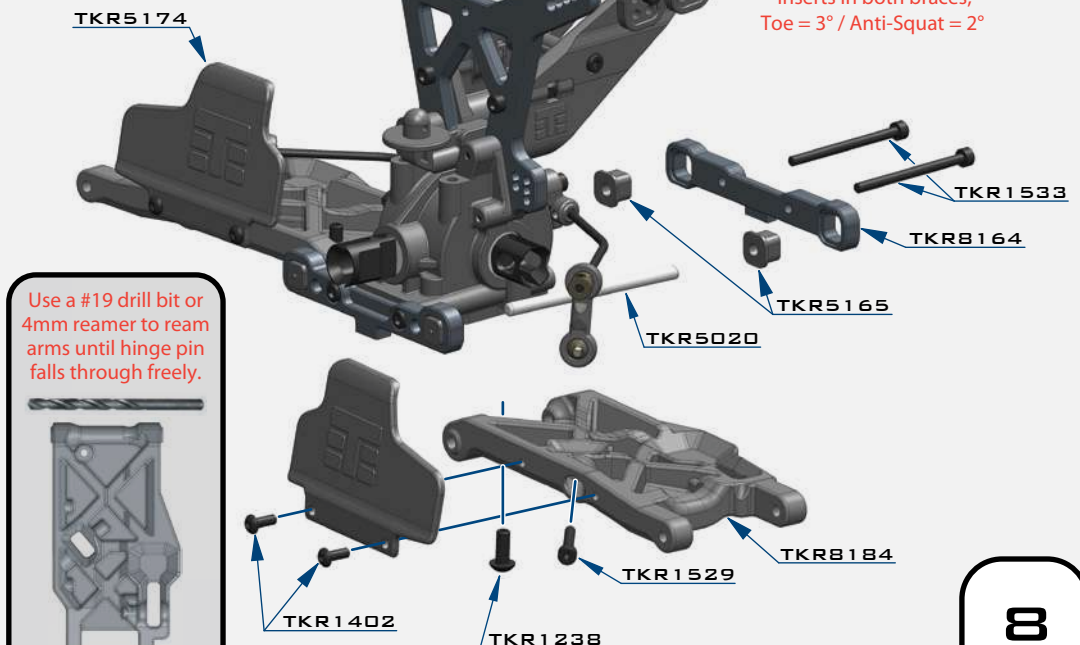

Use a #19 drill bit or 4mm reamer to ream arms until hinge pin falls through freely.



# BAG G

## REAR HUB/CVA ASSEMBLY



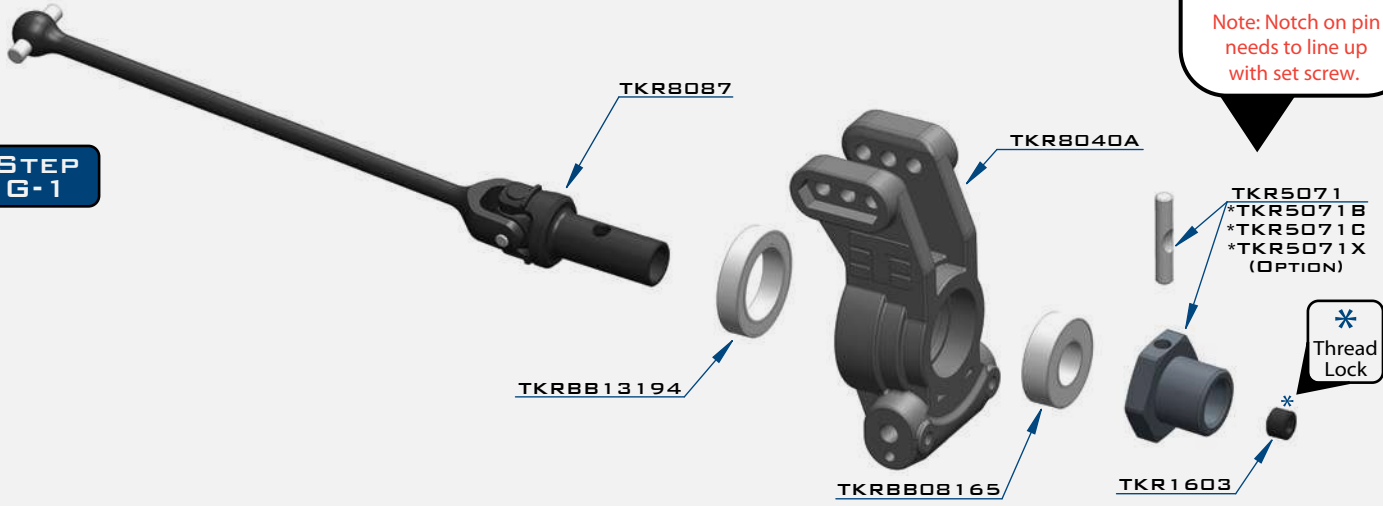

Note: Notch on pin needs to line up with set screw.

### STEP G-1

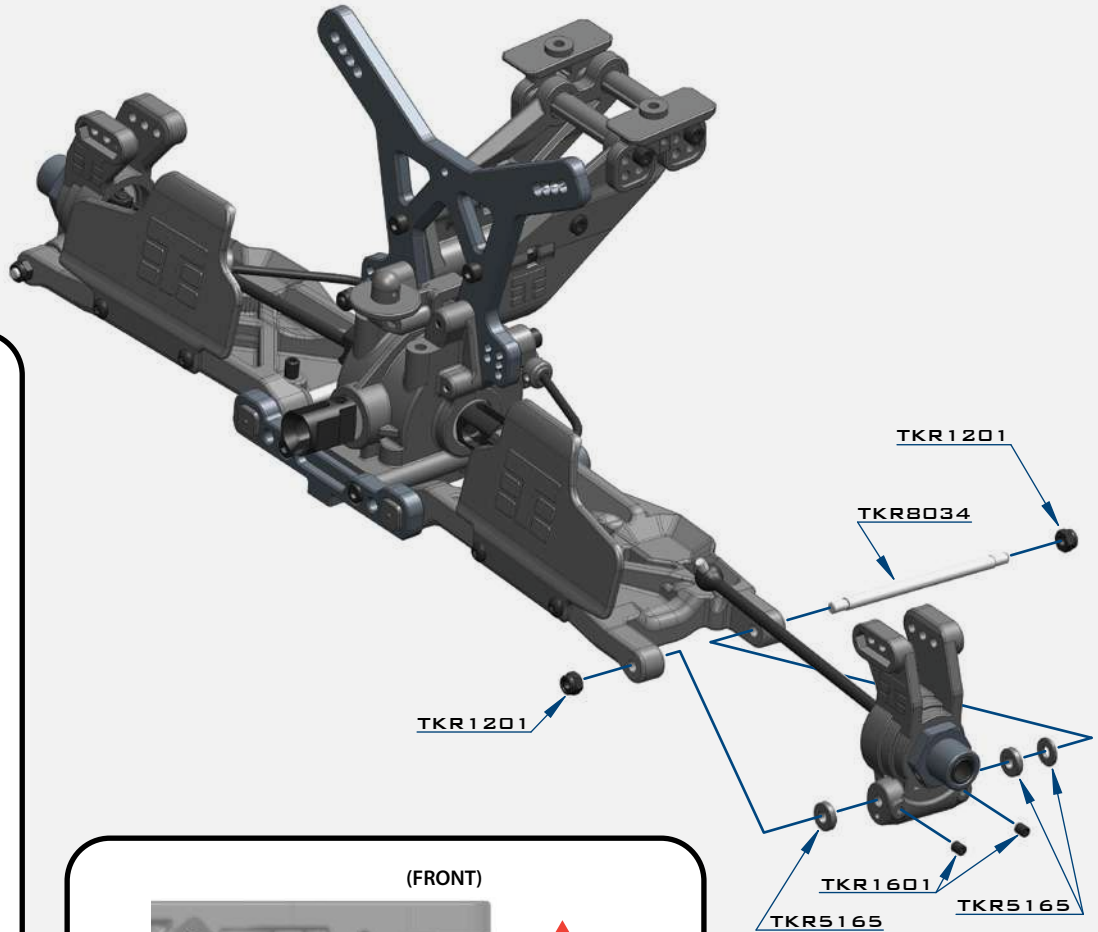

### STEP G-2

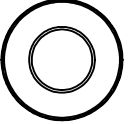
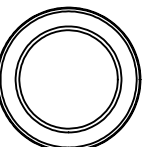

-  x4  
TKR1201  
M3 LOCKNUT BLACK
-  x4  
TKR1601  
M3X4MM SET SCREW
-  x2  
TKR1603  
M5X4MM SET SCREW
-  x2  
TKR5071  
M3X16.8MM PIN
-  x2  
TKRBB08165  
BALL BEARING (8X16X5)
-  x2  
TKRBB13194  
BALL BEARING (13X19X4)

(FRONT)  
(REAR)

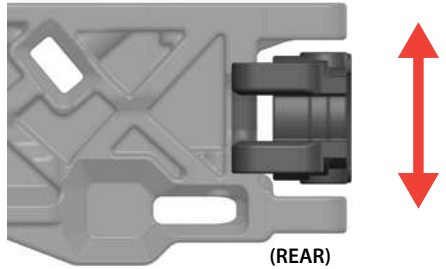

Changes to the wheelbase have a dramatic effect on handling, since it shifts the distribution of weight over the rear wheels. This adjusts traction. By shortening the wheelbase at the rear, you are placing more weight over the rear wheels.

Changes to the wheelbase also change the amount of sweep the rear driveshaft will have. More driveshaft sweep creates an effect similar to anti-squat, where the rear end gets pushed upwards on throttle. This helps reduce chassis slap when landing jumps on throttle.

# BAG G

## REAR CAMBER LINKS

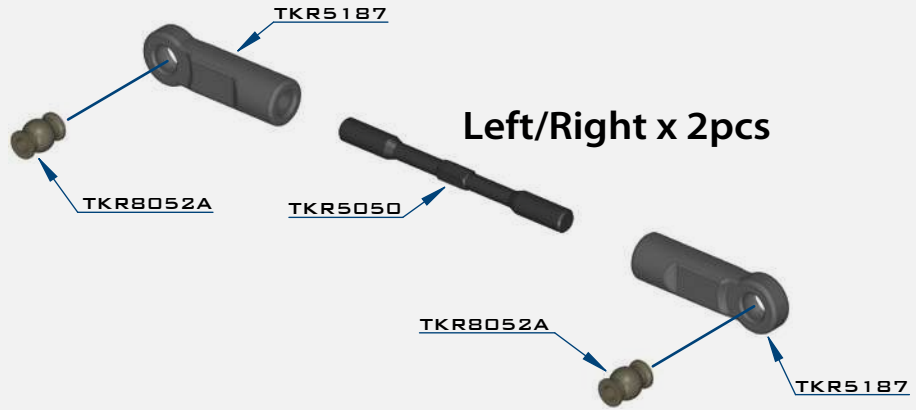

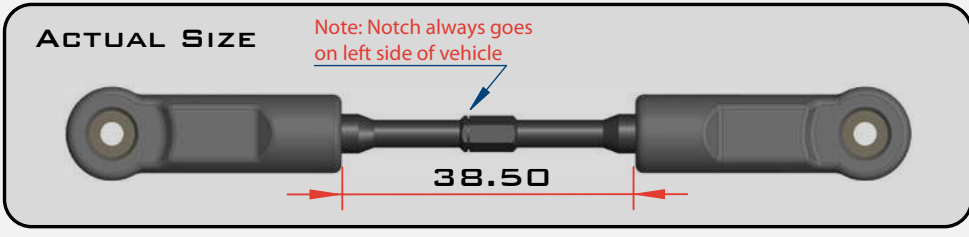

**STEP**  
**G-3**

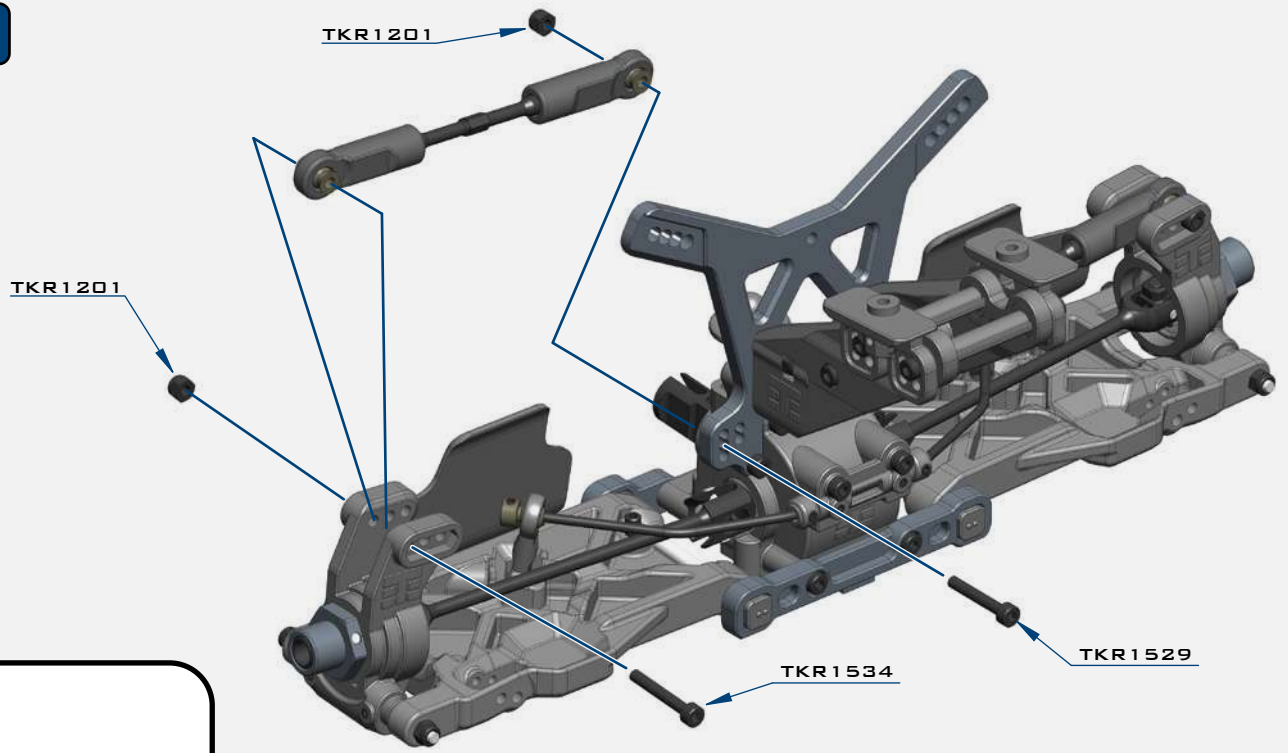

**STEP**  
**G-4**

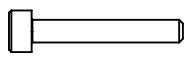
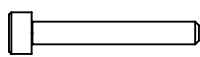

-  x4  
TKR1201  
M3 LOCKNUT BLACK
-  x2  
TKR1529  
M3X20MM CAP HEAD SCREW
-  x2  
TKR1534  
M3X22MM CAP HEAD SCREW
-  x2  
TKR8052A  
PIVOT BALL M3X6.8MM

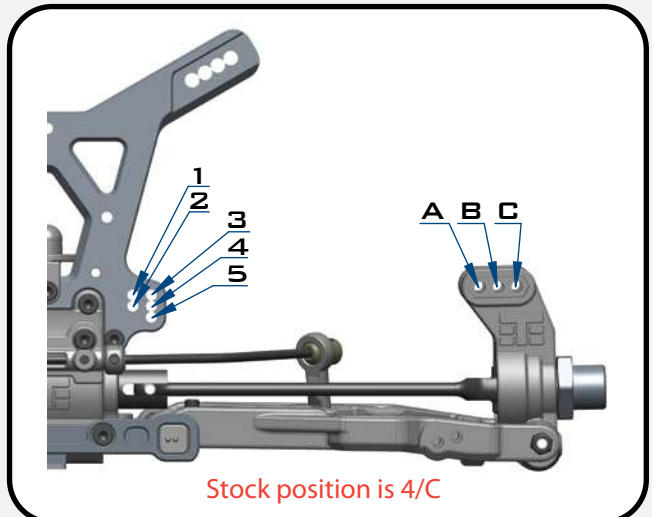

# BAG H

## FRONT END

### STEP H-1

- TKR5081 - 2.3MM
- \*TKR5080 - 2.2MM
- \*TKR5082 - 2.4MM
- \*TKR5083 - 2.5MM
- \*TKR5084 - 2.6MM
- \*TKR5085 - 2.8MM
- \*TKR5087 - 3.0MM (OPTION)

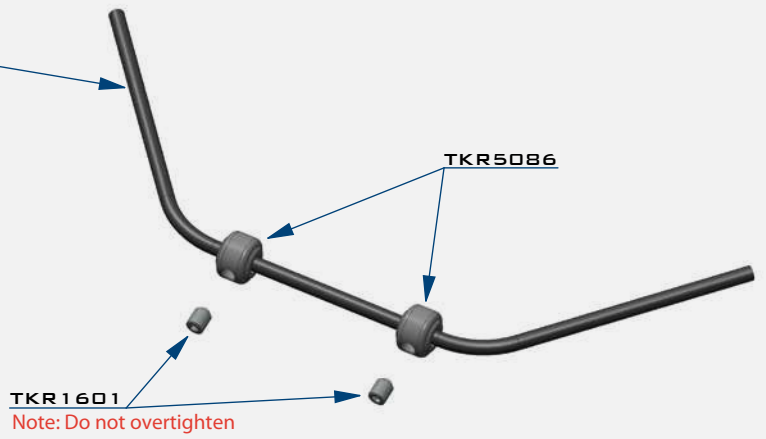
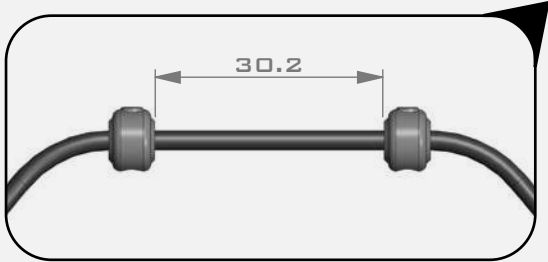

### STEP H-2

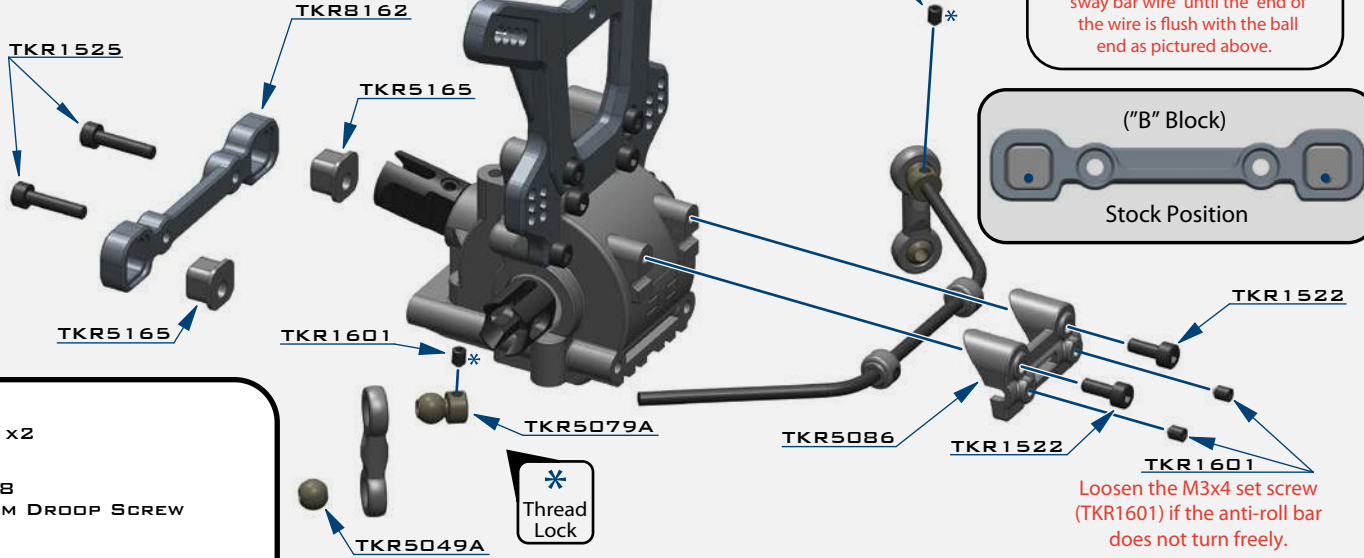

TKR1238  
M4X10MM DROOP SCREW



TKR1522  
M3X8MM CAP HEAD SCREW

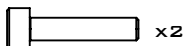

TKR1525  
M3X14MM CAP HEAD SCREW

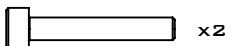

TKR1529  
M3X20MM CAP HEAD SCREW

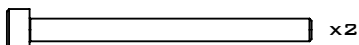

TKR1533  
M3X40MM CAP HEAD SCREW



TKR1601  
M3X4MM SET SCREW



TKR5049A  
PIVOT BALL SWAY BAR

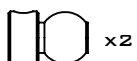

TKR5079A  
STABILIZER BALL

### STEP H-3

Use a #19 drill bit or 4mm reamer to ream arms until hinge pin falls through freely.

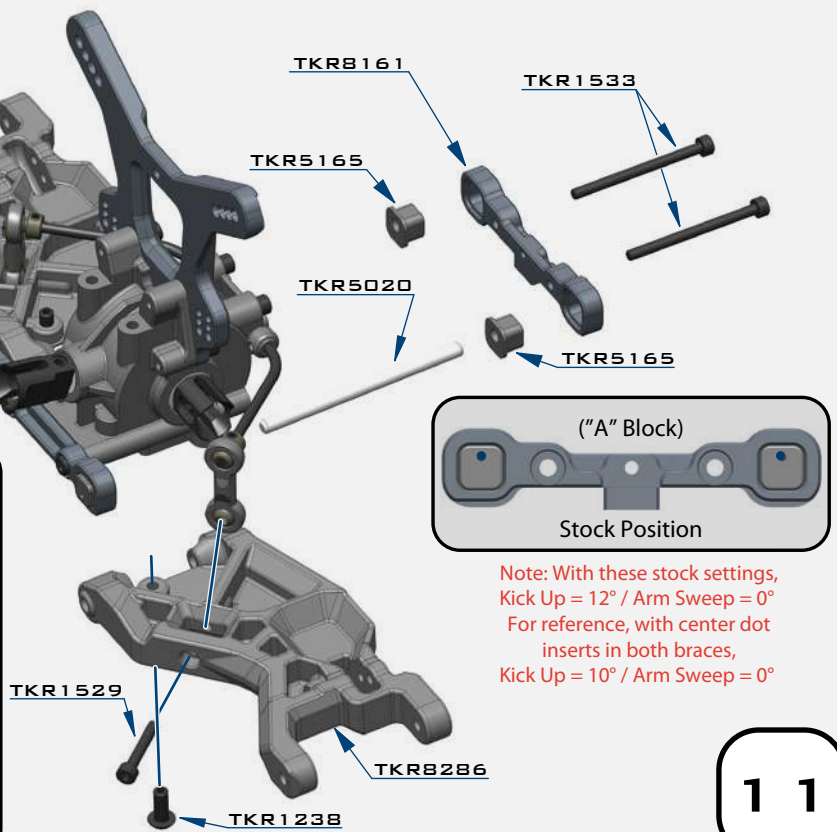
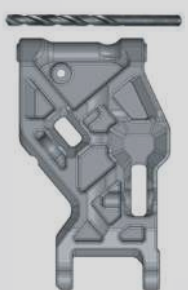

# BAG I

## FRONT SPINDLE / CVA ASSEMBLY

### STEP I-1

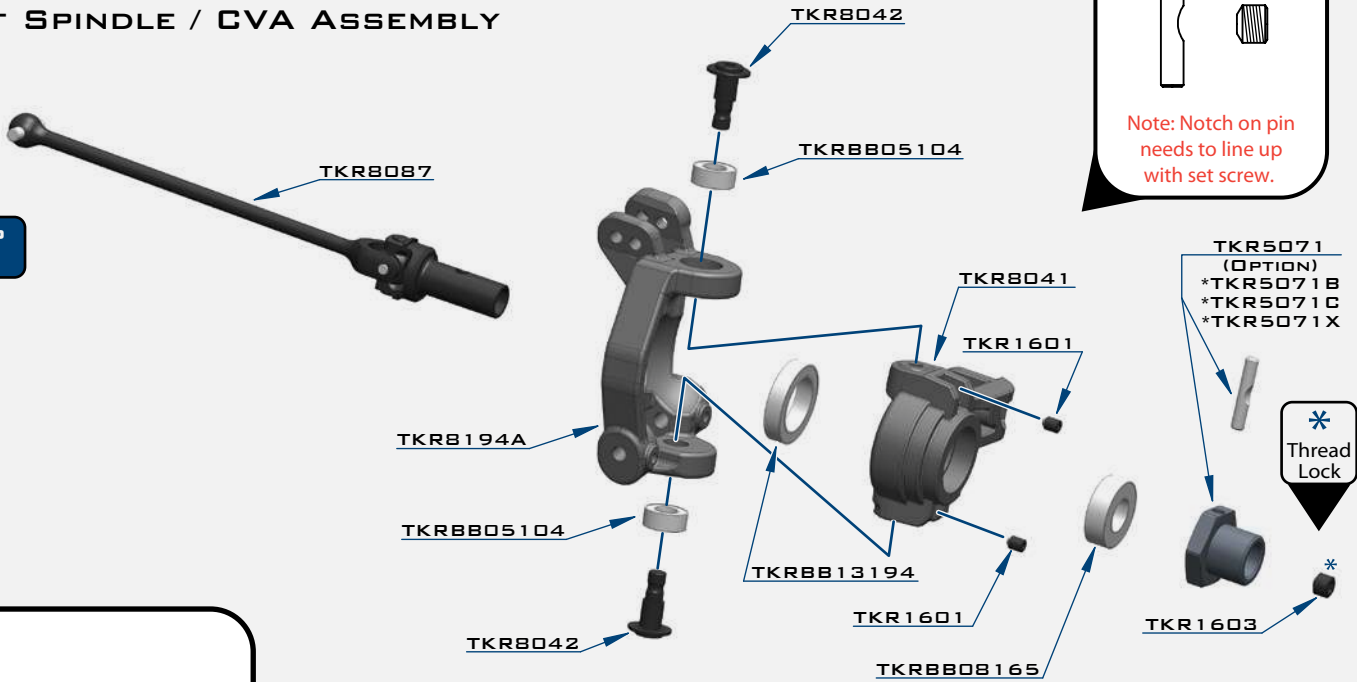

Note: Notch on pin needs to line up with set screw.

\* Thread Lock

x4  
TKR1201  
M3 LOCKNUT BLACK

x2  
TKR1221  
M3x8MM WASHER

x2  
TKR1401  
M3x6MM BUTTON HEAD SCREW

x8  
TKR1601  
M3x4MM SET SCREW

x2  
TKR1603  
M5x4MM SET SCREW

x2  
TKR5071  
M3x16.8MM PIN

x4  
TKRBB05104  
BALL BEARING (5x10x4)

x2  
TKRBB08165  
BALL BEARING (8x16x5)

x2  
TKRBB13194  
BALL BEARING (13x19x4)

Note: The TKR1601 set screws are meant to keep the TKR8042 screws from coming loose. After installing TKR8042 and ensuring the steering action is free, install TKR1601 in the locations indicated. Very slowly tighten the screws until you feel some resistance from contacting the TKR8042 screws. DO NOT OVERTIGHTEN. Also be sure to loosen TKR1601 before unscrewing TKR8042 or you will damage the screws and the parts.

### DO NOT SKIP THIS STEP!

### STEP I-2

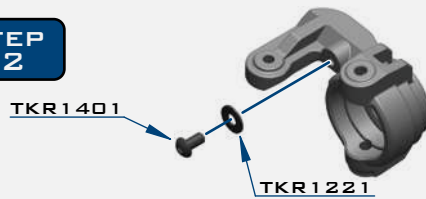

Note: The steering stops provide adjustable travel limiters to control overall steering throw. We recommend 1 washer on each side. With too much steering travel, the rear end will lose traction around corners, the vehicle will be very hard to drive and it will be more prone to breaking parts.

### STEP I-3

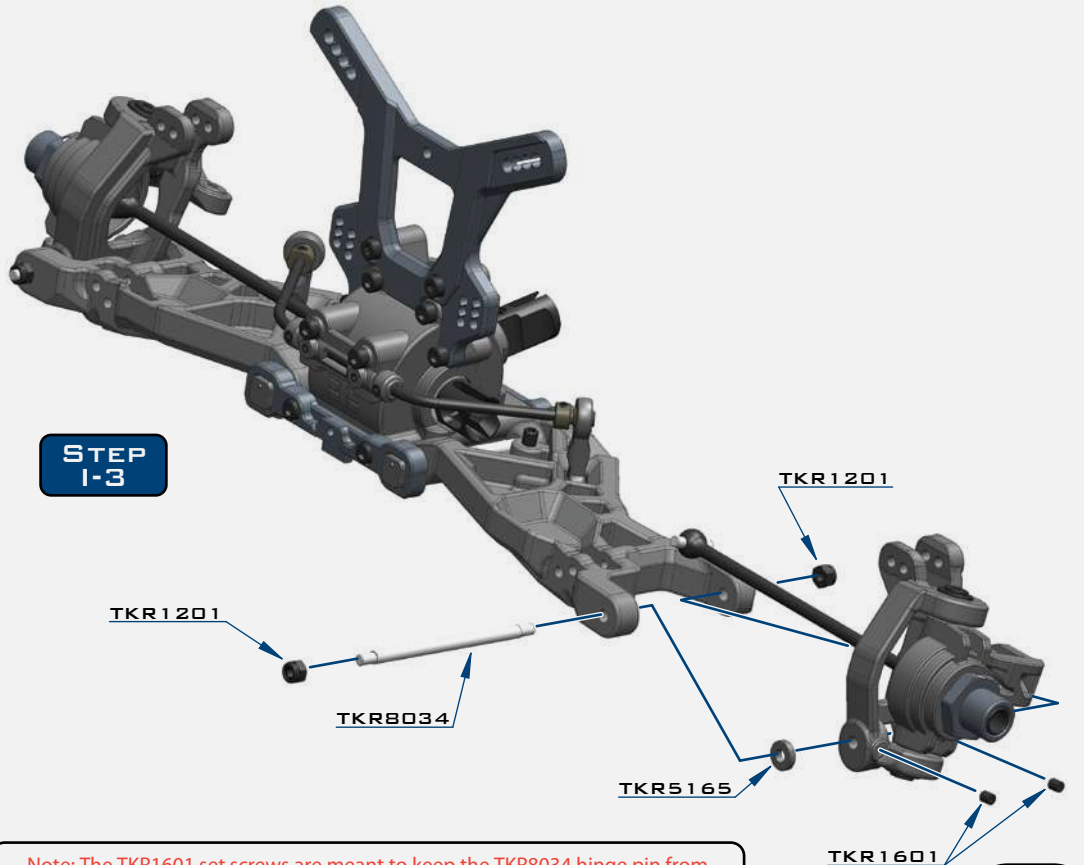

Note: The TKR1601 set screws are meant to keep the TKR8034 hinge pin from rotating. After installing TKR8034, install the TKR1601 in the locations indicated. Very slowly tighten the screws until you feel some resistance from contacting the TKR8034 hinge pin. DO NOT OVERTIGHTEN. Also be sure to loosen TKR1601 before removing TKR8034 or you will damage the hinge pin.

# BAG I

## FRONT CAMBER LINKS

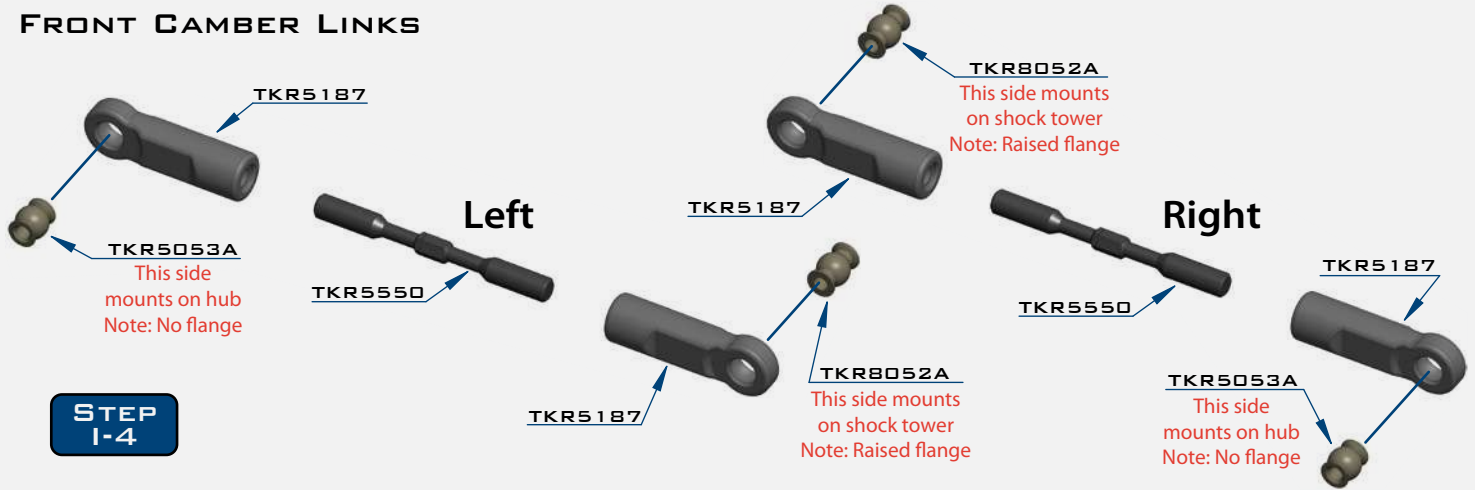

**STEP 1-4**

**STEP 1-5**

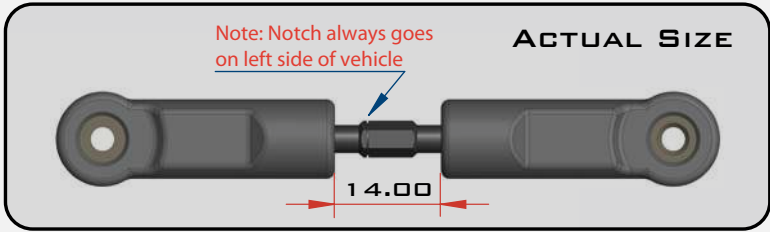
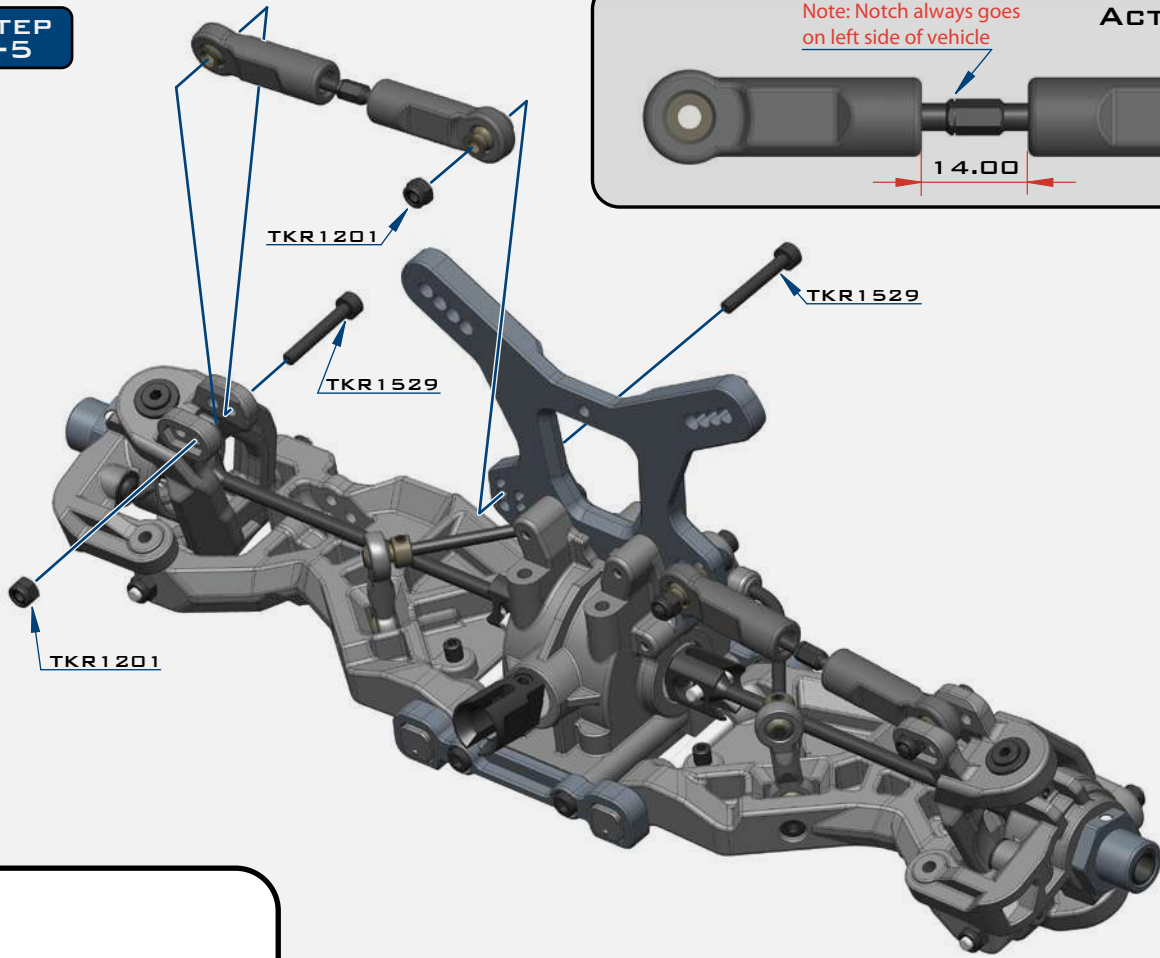

x4  
TKR1201  
M3 LOCK NUT BLACK

x4  
TKR1529  
M3X20MM CAP HEAD SCREW

x2  
TKR5053A  
PIVOT BALL M3X6.8MM  
NO FLANGE

x2  
TKR8052A  
PIVOT BALL M3X6.8MM

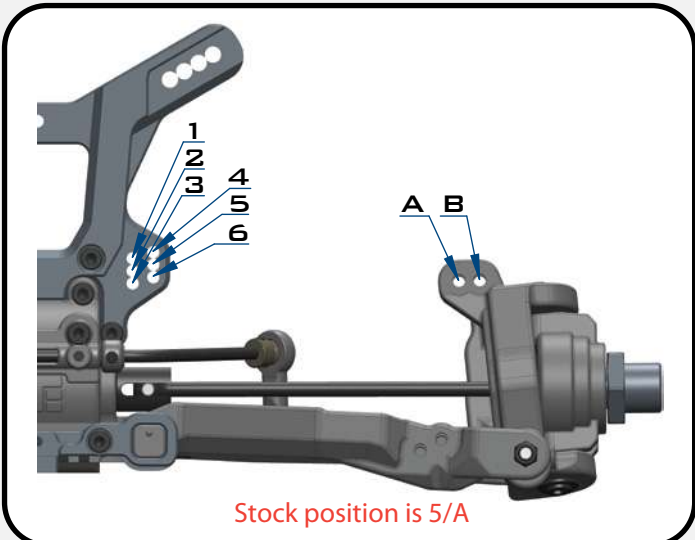

Stock position is 5/A

# BAG J

## STEERING ASSEMBLY (OVERVIEW)

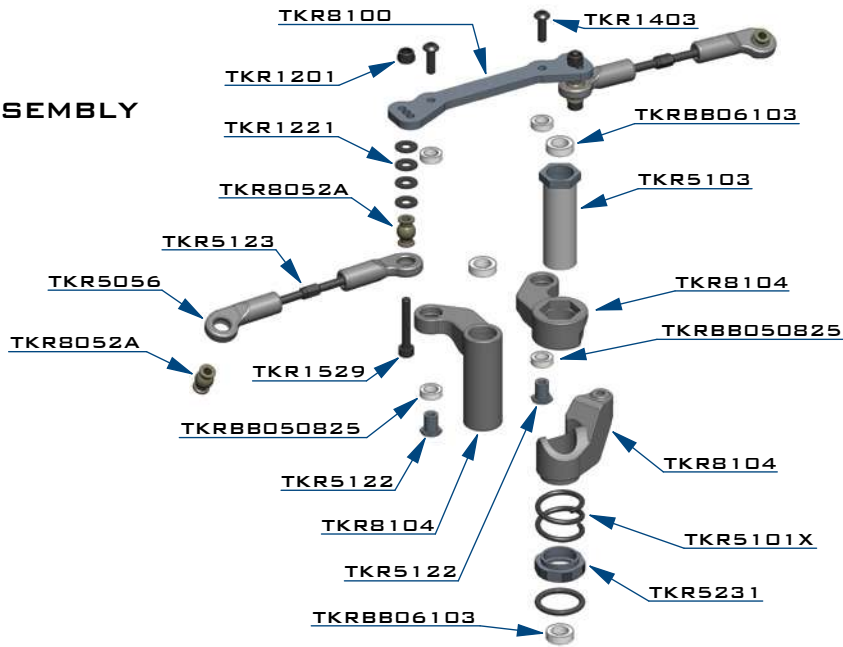

### STEP J-1





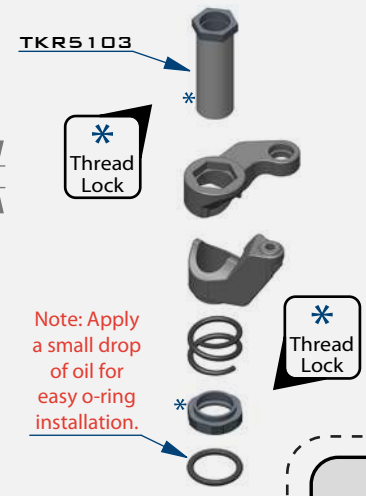



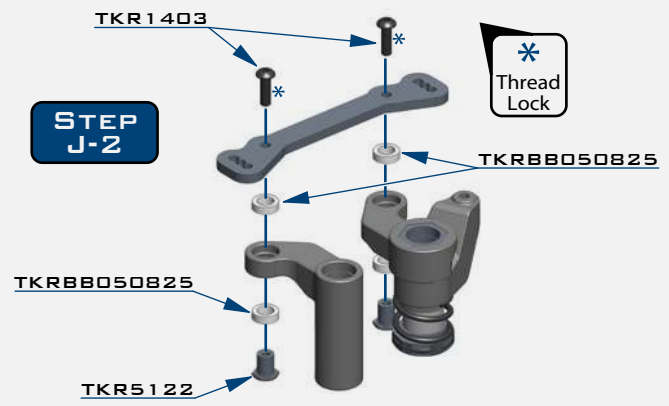

Note: Tighten nut all the way down, then back it off 3 full turns



Note: Apply a small drop of oil for easy o-ring installation.

### STEP J-2

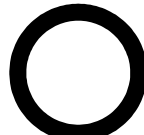

-  x2  
TKR1201  
M3 LOCK NUT BLACK
-  x8  
TKR1221  
M3X8MM WASHER
-  x2  
TKR1403  
M3X10MM BUTTON HEAD SCREW
-  x2  
TKR1529  
M3X20MM CAP HEAD SCREW
-  x4  
TKR8052A  
PIVOT BALL M3X6.8MM
-  x1  
TKR5231  
O-RING 16X12X2
-  x4  
TKRBB050825  
BALL BEARING (5X8X2.5)
-  x4  
TKRBB06103  
BALL BEARING (6X10X3)

### STEP J-3

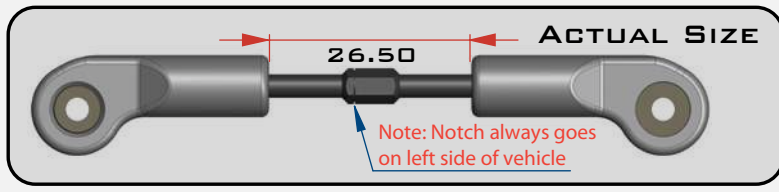

Left/Right x 2pcs

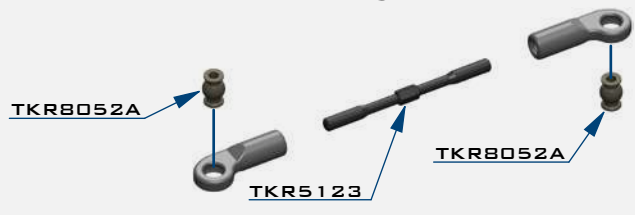

### STEP J-4

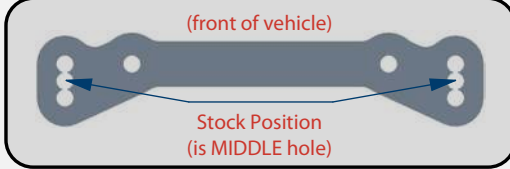
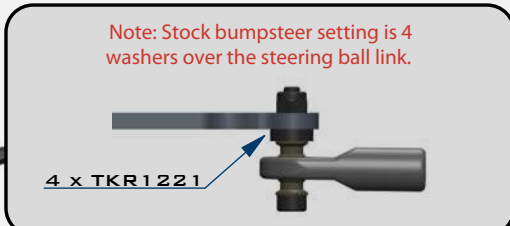
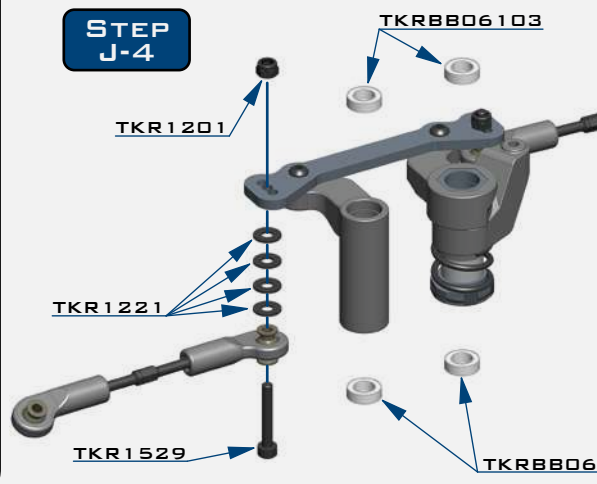

# BAG K

## FRONT END ASSEMBLY

### STEP K-1

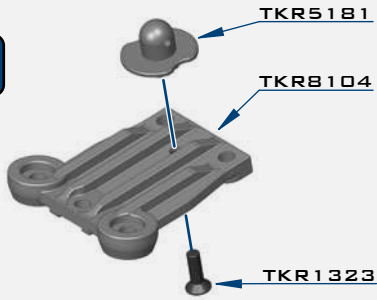

### STEP K-2

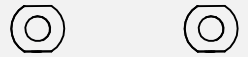
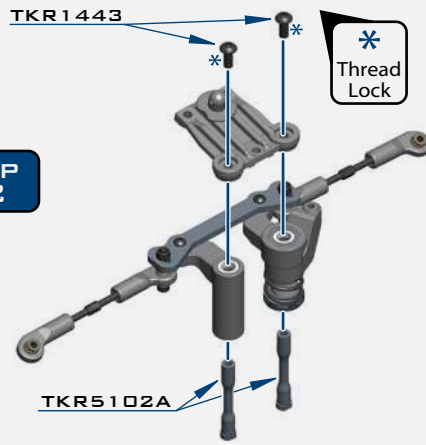

Note: On step K-4:  
Line up the bottom of the steering posts (TKR5102A) with the corresponding recess cut in the chassis.

### STEP K-3

Note: Initial bumpsteer setting is four washers below the steering ball link.

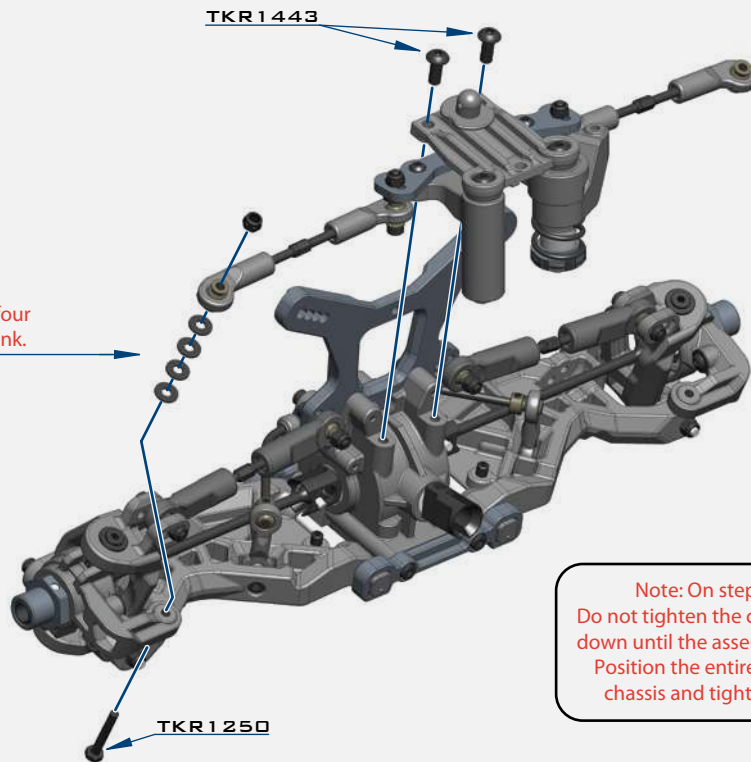

Note: On steps K-2, K-3 and K-4:  
Do not tighten the chassis screws all the way down until the assembly steps are complete. Position the entire front assembly on the chassis and tighten each screw evenly.

x2  
TKR1201  
M3 LOCK NUT BLACK

x8  
TKR1221  
M3x8MM WASHER

x2  
TKR1250  
M3 STEERING LINK SCREW

x1  
TKR1323  
M3x10MM FLAT HEAD SCREW

x2  
TKR1343  
M4x10MM FLAT HEAD SCREW

x6  
TKR1344  
M4x12MM FLAT HEAD SCREW

x5  
TKR1443  
M4x10MM BUTTON HEAD SCREW

x1  
TKR1522  
M3x8MM CAP HEAD SCREW

### STEP K-4

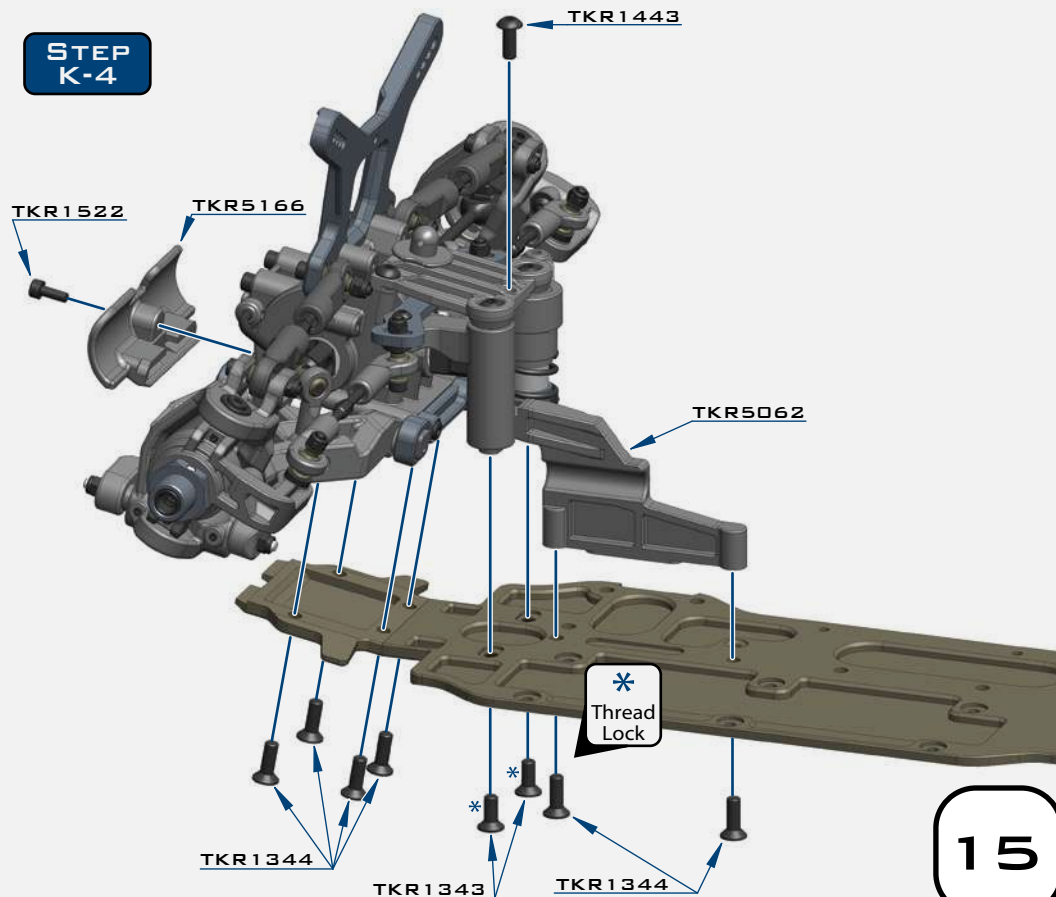

# BAG L

## CENTER/REAR ASSEMBLY

**STEP L-1**

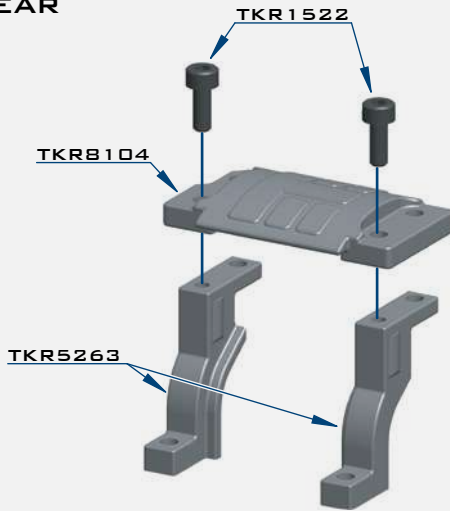

**STEP L-2**

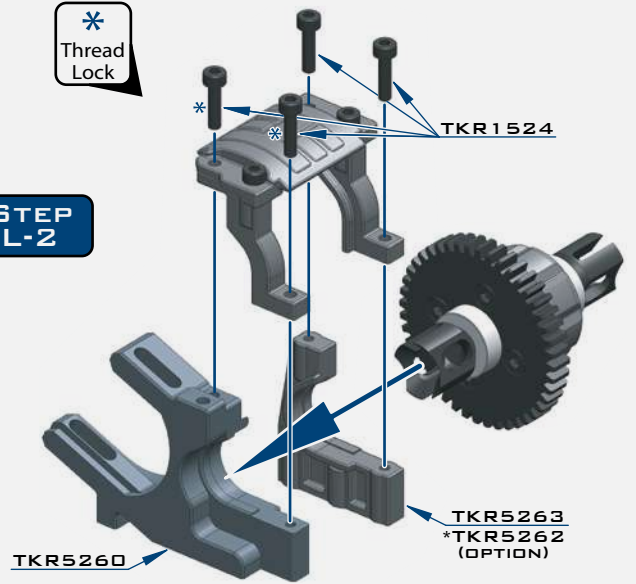

**STEP L-3**

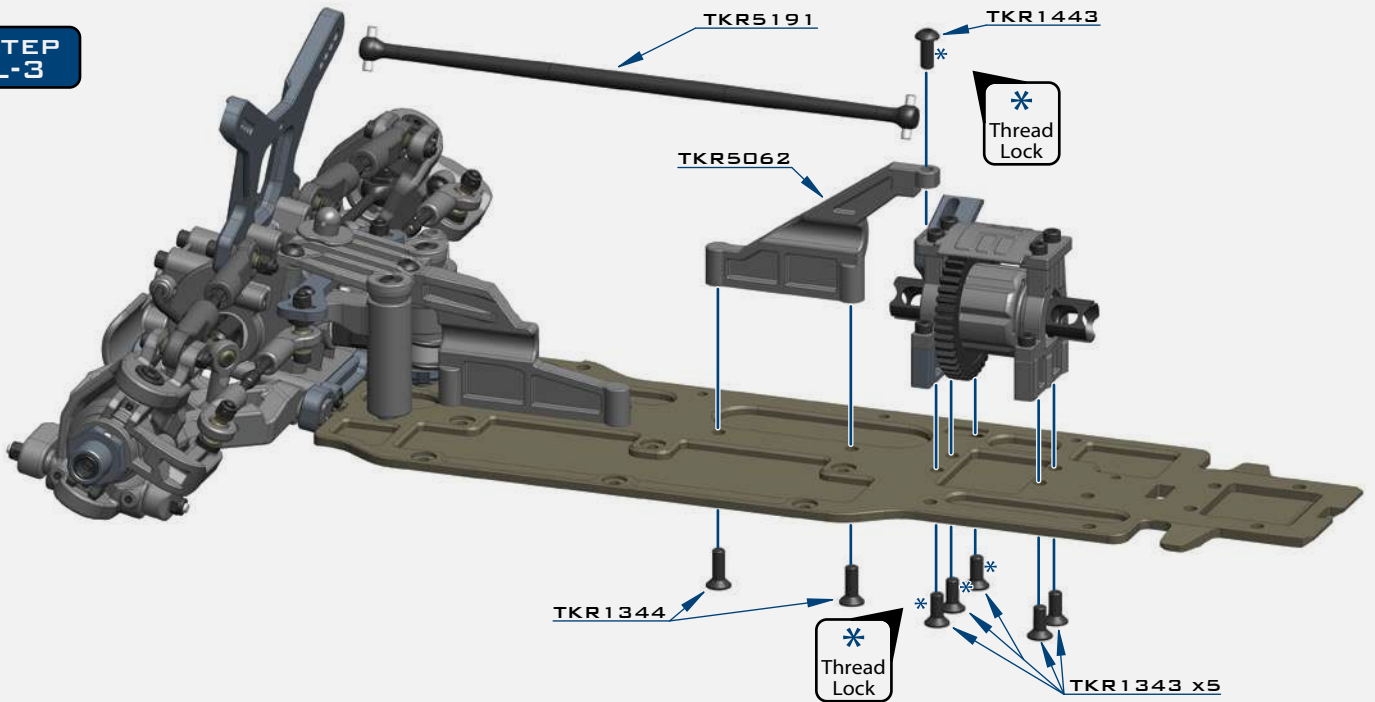

**STEP L-4**

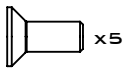

x5  
TKR1343  
M4X10MM FLAT HEAD SCREW



x7  
TKR1344  
M4X12MM FLAT HEAD SCREW

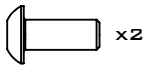

x2  
TKR1443  
M4X10MM BUTTON HEAD SCREW

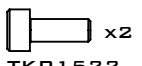

x2  
TKR1522  
M3X8MM CAP HEAD SCREW

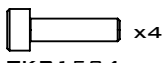

x4  
TKR1524  
M3X12MM CAP HEAD SCREW

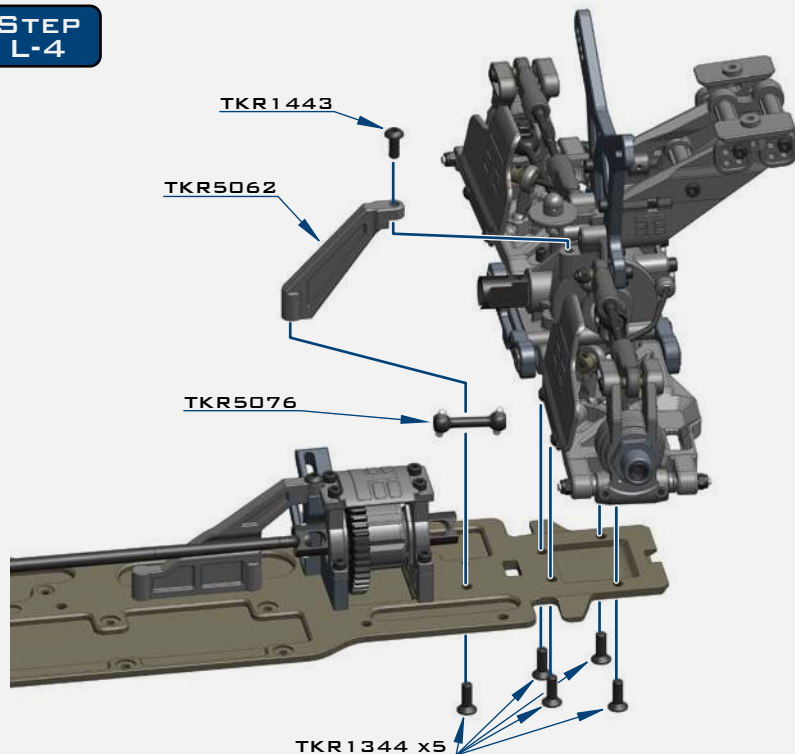



# BAG M

## FRONT SHOCK ASSEMBLY

### STEP M-1

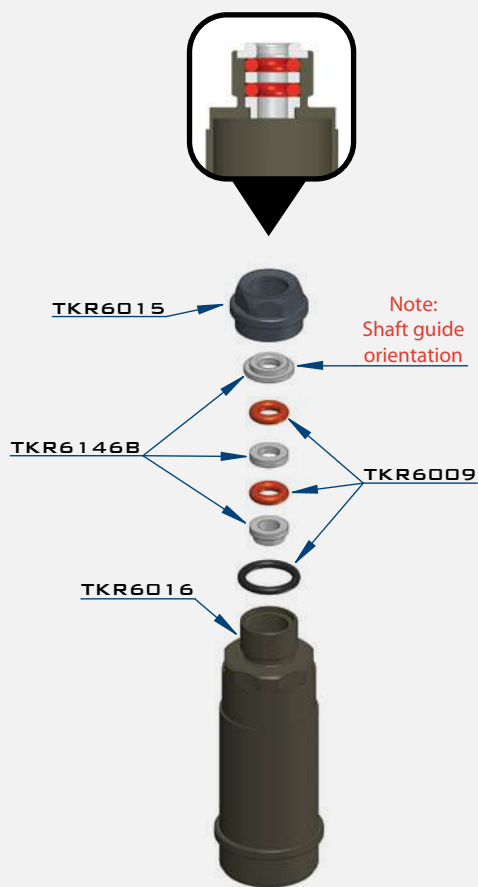

### STEP M-2



### STEP M-3

Refer to filling instructions on page 19 during this step.

Use #550wt oil FRONT

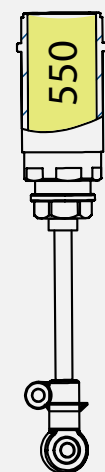

### STEP M-4

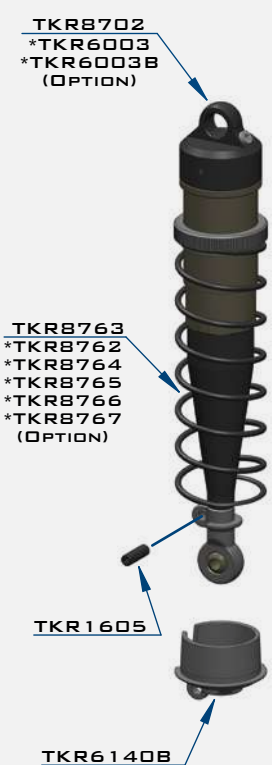



 x2  
TKR1200  
M2.5 LOCK NUT ZINC

 x2  
TKR1202  
M4 LOCK NUT BLACK

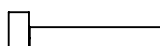
 x2  
TKR1211  
M3 LOCK NUT FLANGE BLACK

 x2  
TKR1240  
M3X18MM SHOCK MNT SCREW

 x2  
TKR1248  
M2X4MM EMULSION SCREW

 x2  
TKR1605  
M3X10MM SET SCREW

### STEP M-5

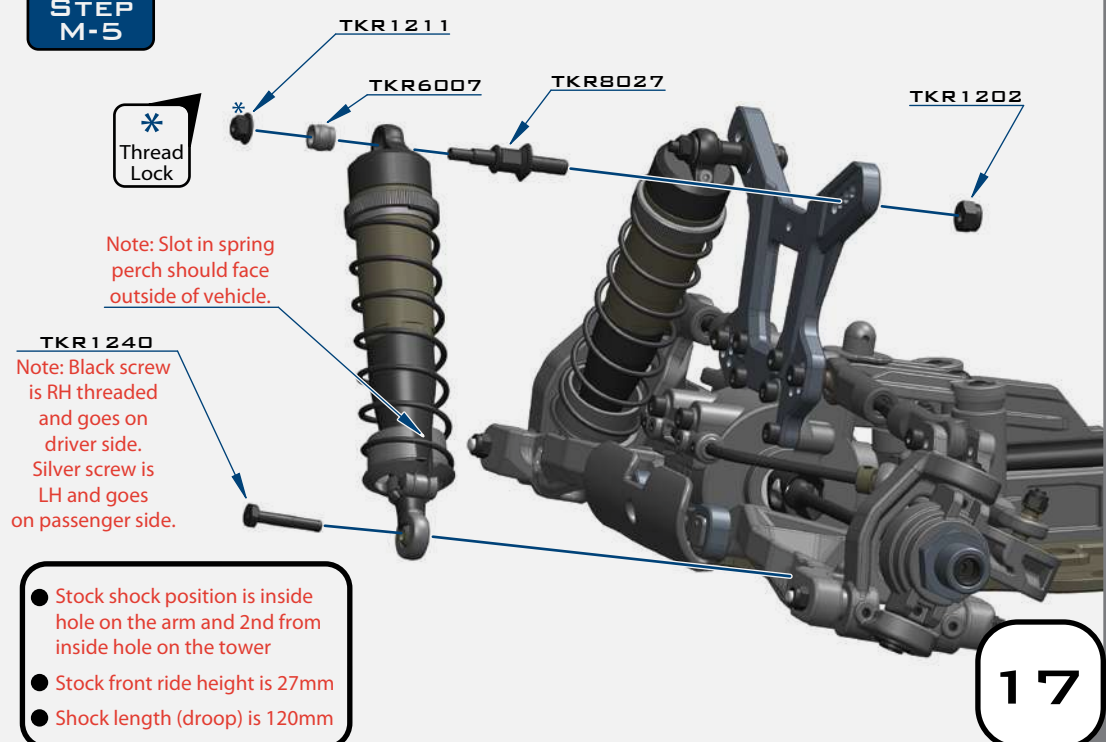

 Thread Lock

TKR1240  
Note: Black screw is RH threaded and goes on driver side. Silver screw is LH and goes on passenger side.

- Stock shock position is inside hole on the arm and 2nd from inside hole on the tower
- Stock front ride height is 27mm
- Shock length (droop) is 120mm

# BAG N

## REAR SHOCK ASSEMBLY

### STEP N-1

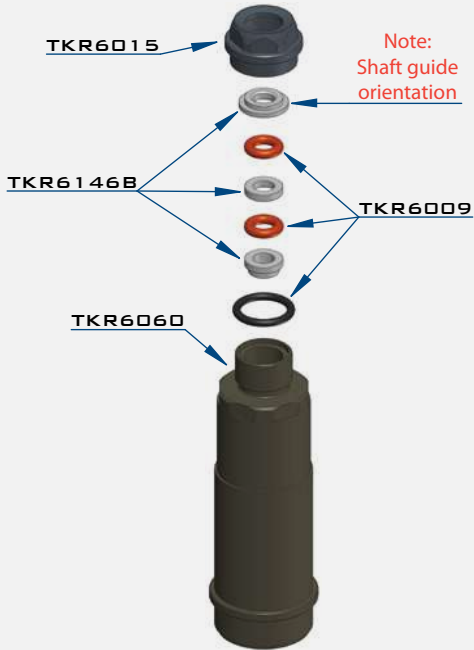
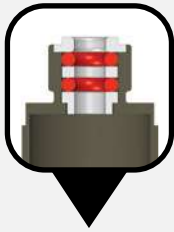

### STEP N-2



### STEP N-3

Refer to filling instructions on page 19 during this step.

Use #450wt oil REAR



### STEP N-4

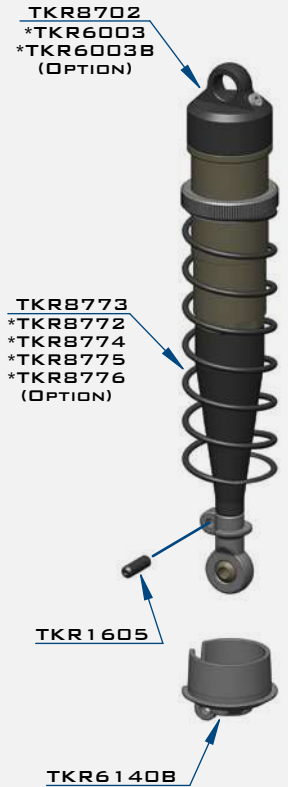

 x2  
TKR1200  
M2.5 LOCK NUT ZINC

 x2  
TKR1202  
M4 LOCK NUT BLACK

 x2  
TKR1211  
M3 LOCK NUT FLANGE BLACK

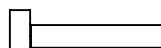
 x2  
TKR1240  
M3X18MM SHOCK MNT SCREW

 x2  
TKR1248  
M2X4MM EMULSION SCREW

 x2  
TKR1605  
M3X10MM SET SCREW

### STEP N-5

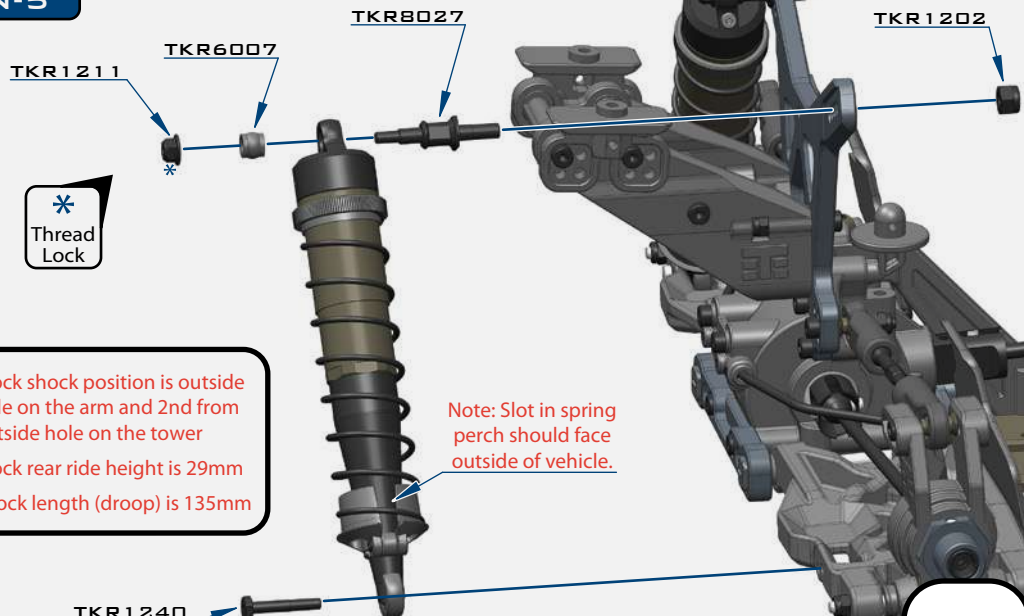

Note: Black screw is RH threaded and goes on passenger side. Silver screw is LH and goes on driver side.

# SHOCK FILLING INSTRUCTIONS

FOR BOTH FRONT AND REAR SHOCKS

We've found it's easiest to complete steps 1 & 2 on each shock before moving on to step 3. By the time you've finished step 2 on the last shock, the first one will be ready for step 3.

**Step 1.** Insert all four larger o-rings into the emulsion caps and set aside. Install the small o-rings onto the small emulsion screws by placing the o-rings on a pit mat or towel and pressing the screws into the o-rings.

**Step 2.** Fill shock with oil all the way to the top and pump the shock shaft up and down 3-5 times.

**Step 3.** Screw on the cap all the way tight (shock tool TKR1115 is helpful in tightening completely).

**Step 4.** With the shock at about a 45° angle, push and hold the shock shaft to the top and insert the prepared emulsion screw/seal. Oil will leak out during this process. Tighten the screw until snug (do not overtighten).

**Step 5.** Pump the shock shaft up and down about 30 times vigorously. This emulsifies the oil.

**Step 6.** With the shock shaft fully extended, remove the emulsion screw from the cap to do the final bleed.

**Step 7.** With the shock at about a 45° angle, push and hold the shock shaft to the top and insert the prepared emulsion screw/seal again. Oil will leak out during this process. Tighten the screw until snug (do not overtighten).

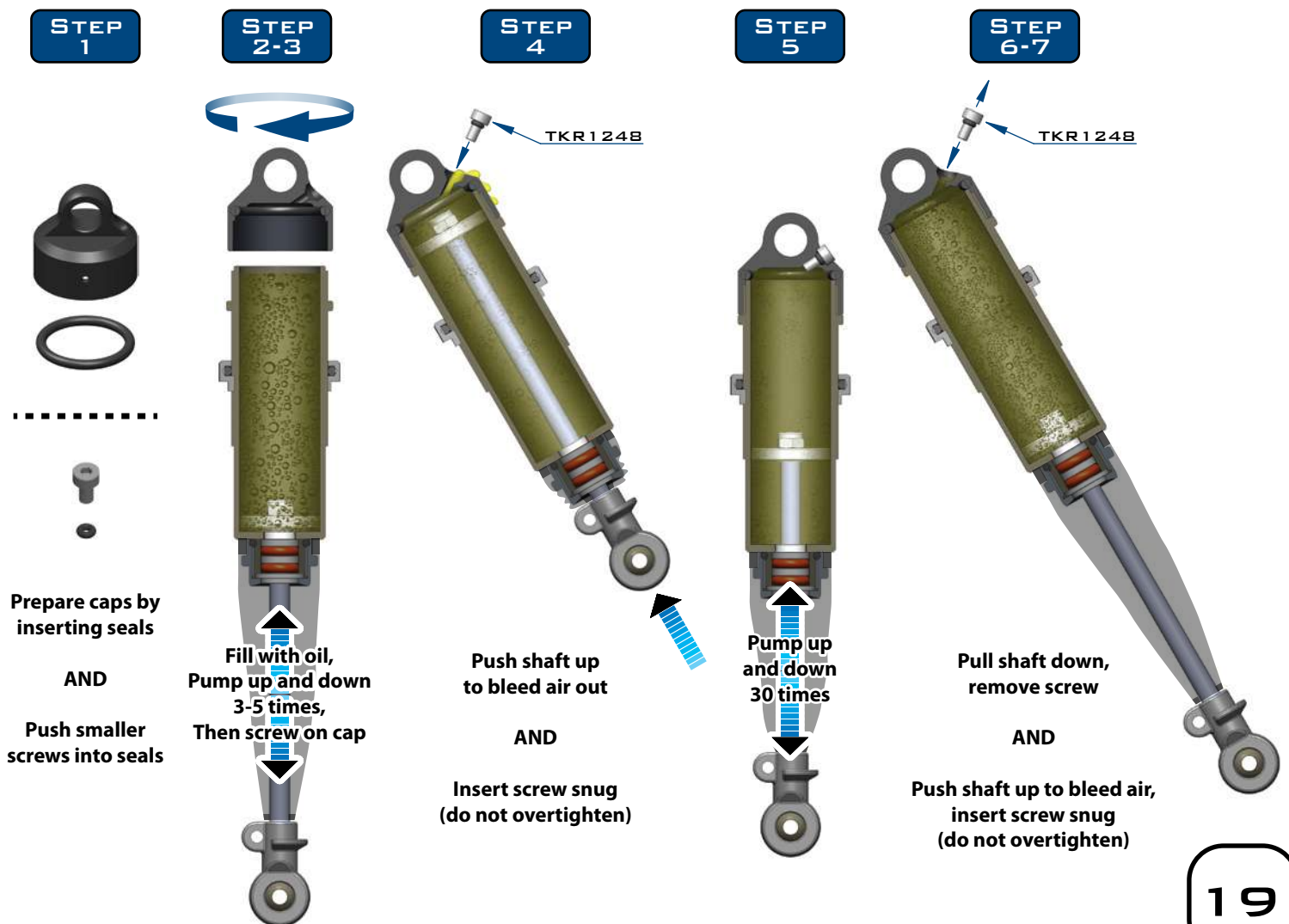

# BAG 0

## FINAL ASSEMBLY

Steering servo (not included)  
 Note: we recommend using a servo with at least 300 oz/in torque.

### STEP 0-1

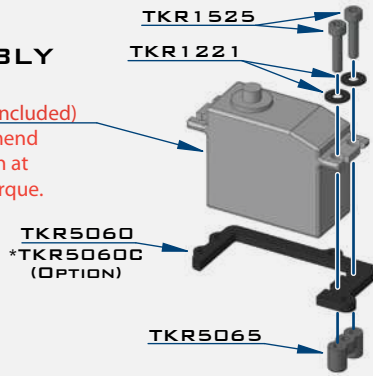

Electronic Speed Control (not included)

### STEP 0-2

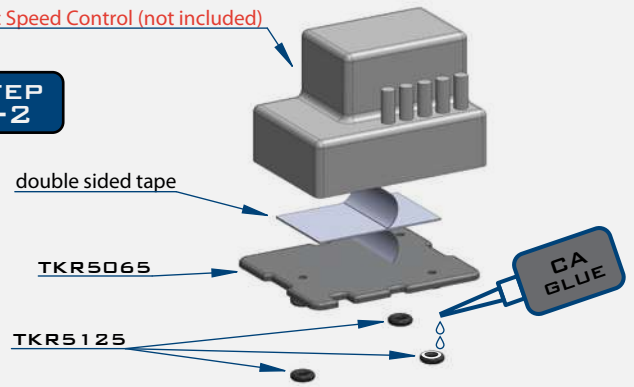

Note: CA glue 3 black o-rings (TKR5125) to the bottom legs of the ESC tray.

### STEP 0-3

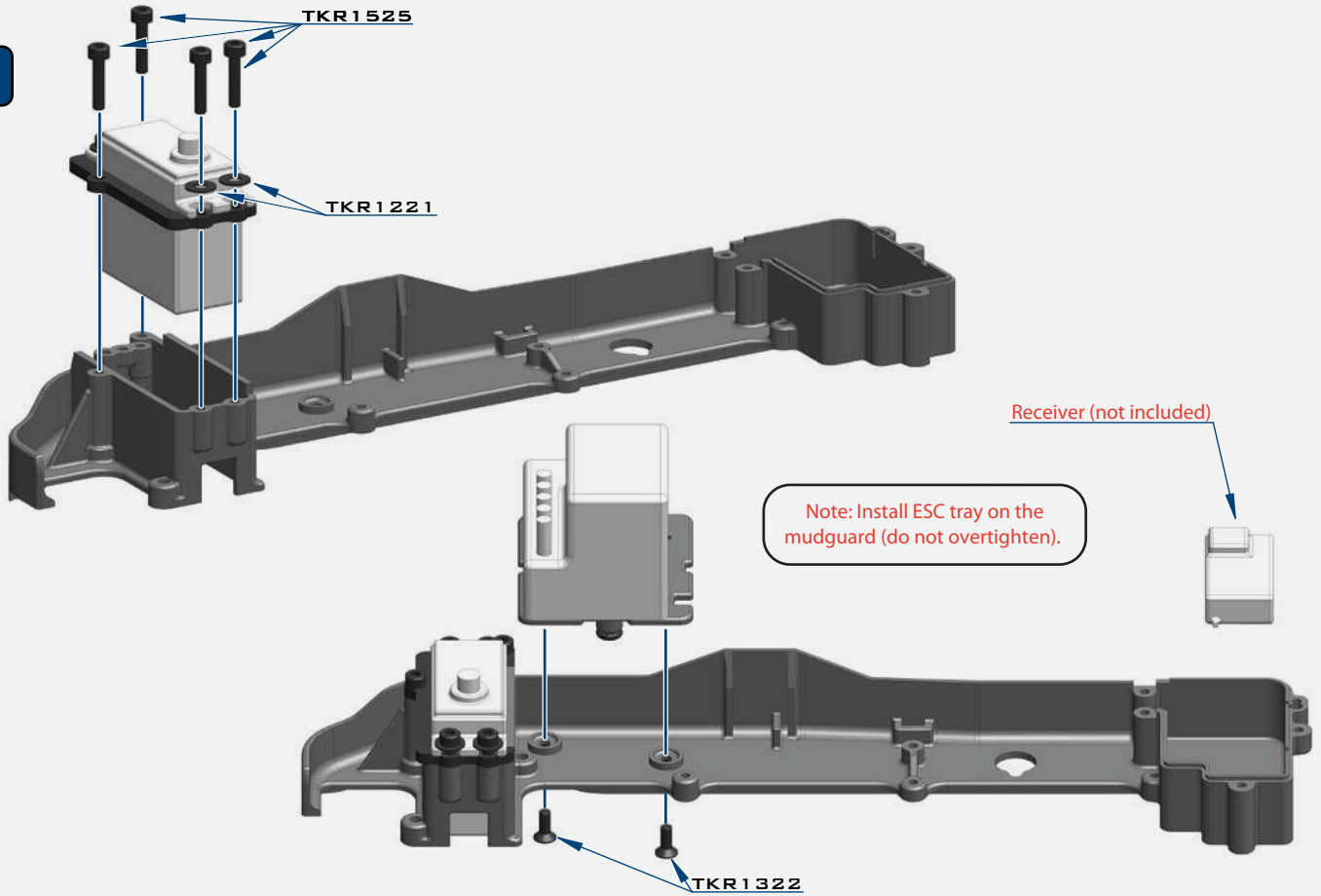

### STEP 0-4

Note: Feed the servo wire underneath the esc tray in between the mounting screws on the mud guard, then feed both ESC and servo wires into the RX box as shown. Install wire retainers (TKR5065) to secure them properly.

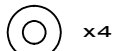
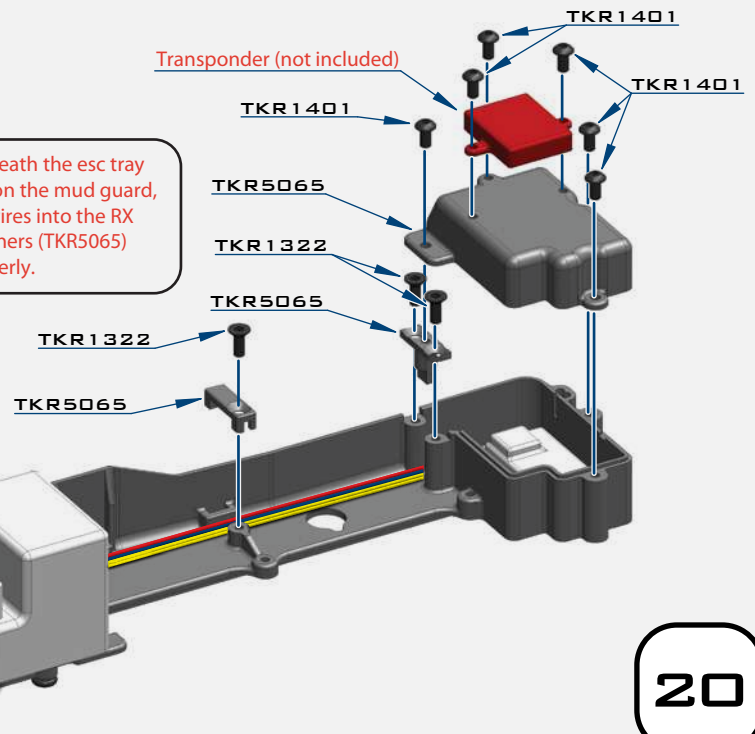

x4

TKR1221  
M3X8MM WASHER

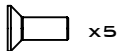

x5

TKR1322  
M3X8MM FLAT HEAD SCREW

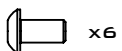

x6

TKR1401  
M3X6MM BUTTON HEAD SCREW

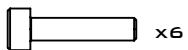

x6

TKR1525  
M3X14MM CAP HEAD SCREW



x3

TKR5125  
O-RING 3X7MM

# BAG P

## FINAL ASSEMBLY

**STEP P-1**

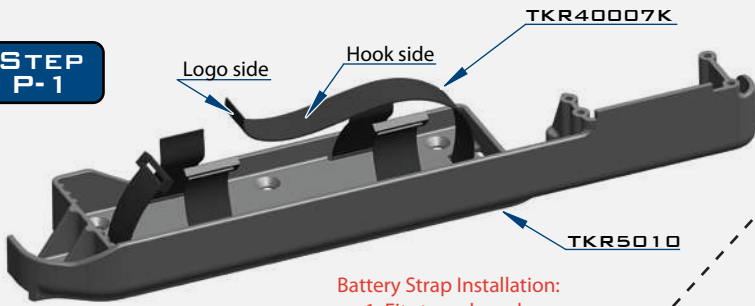

**Battery Strap Installation:**  
 1. Fit straps loosely  
 2. Position on chassis  
 3. Proceed to step P-2

**Motor (not included)**

**STEP P-2**

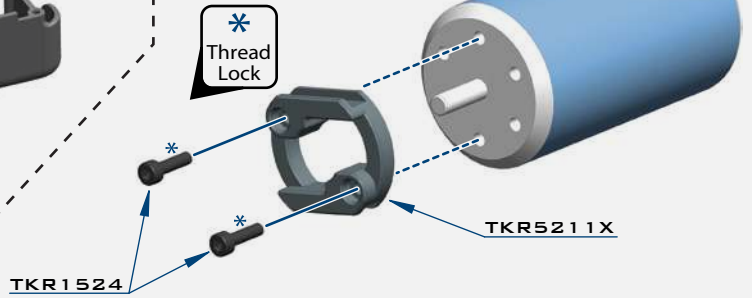

**STEP P-3**

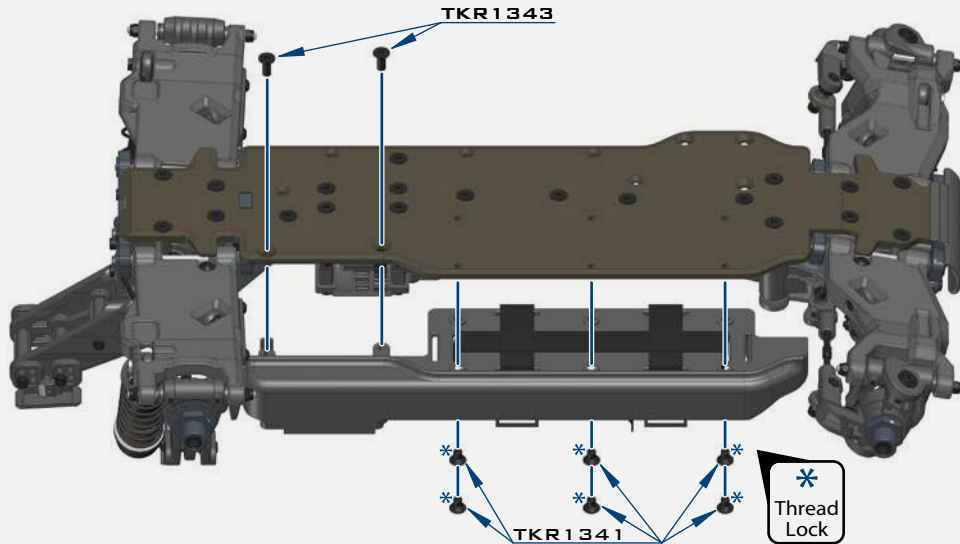

**STEP P-4**

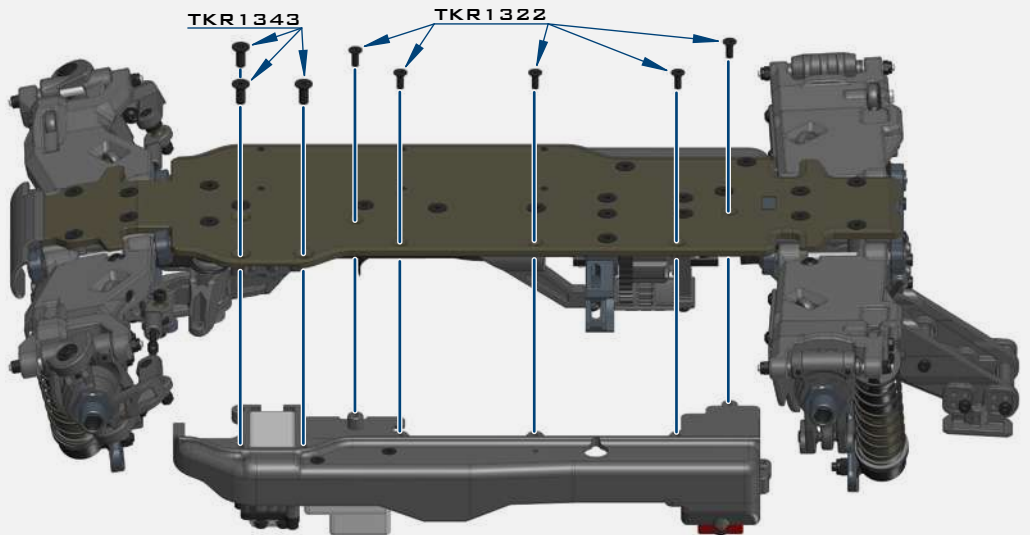

**STEP P-5**

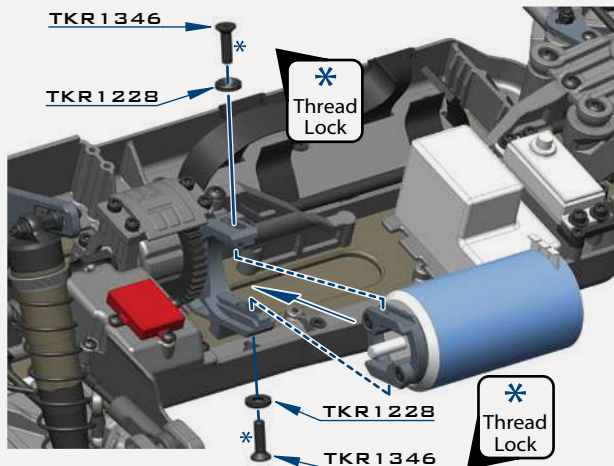

Note: Install MOD1 pinion 15t-25t (TKR4175-4185) at this step. Adjust gear mesh and tighten screws (TKR1346) well. \*Use thread lock.

 X2  
 TKR1228  
 M4 COUNTERSUNK WASHER

 X5  
 TKR1322  
 M3X8MM FLAT HEAD SCREW

 X6  
 TKR1341  
 M4X6MM FLAT HEAD SCREW

 X5  
 TKR1343  
 M4X10MM FLAT HEAD SCREW

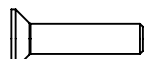
 X2  
 TKR1346  
 M4X15MM FLAT HEAD SCREW

 X2  
 TKR1524  
 M3X12MM CAP HEAD SCREW

# BAG P

## FINAL ASSEMBLY

### STEP P-6

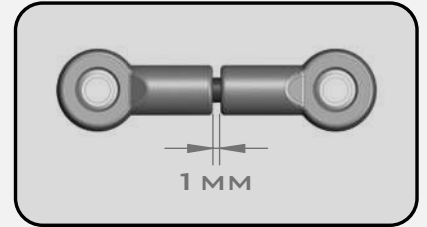
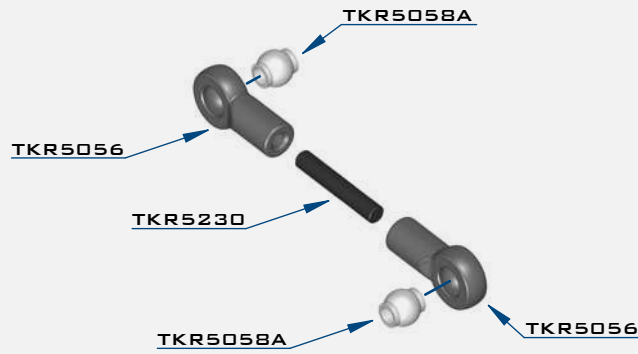

### STEP P-7

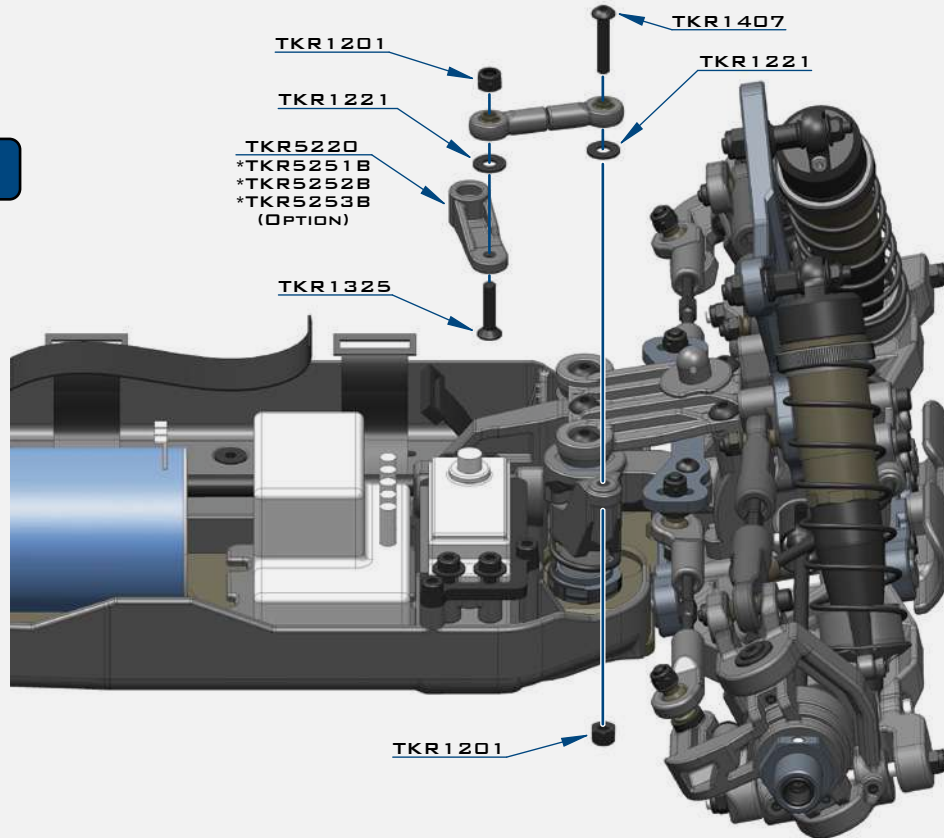



 x2  
TKR1201  
M3 LOCK NUT BLACK

 x2  
TKR1221  
M3X8MM WASHER

 x1  
TKR1325  
M3X14MM FLAT HEAD SCREW

 x1  
TKR1407  
M3X16MM BUTTON HEAD SCREW

 x2  
TKR5058A  
PIVOT BALL M3X5.8MM  
NO FLANGE

 x1  
TKR5230  
M3X18 THREADED ROD

### STEP P-8

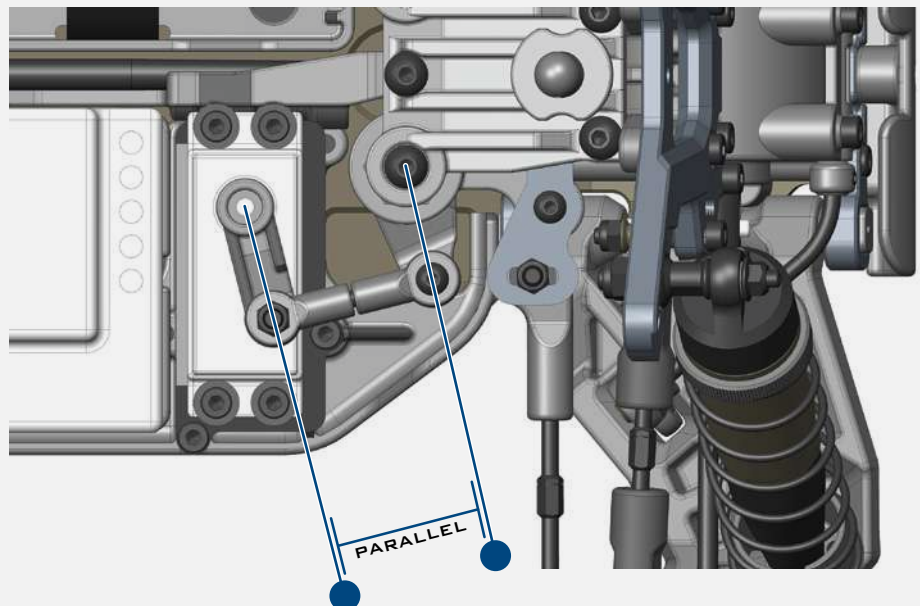

Note: Offset servo arm so it is parallel with the connecting arm at neutral or zero servo position.

# BAG Q

## WING/WHEELS/BODY

### STEP Q-1

#### WING HOLE OPTIONS

(Use Dimples as Hole Cutting Guides)

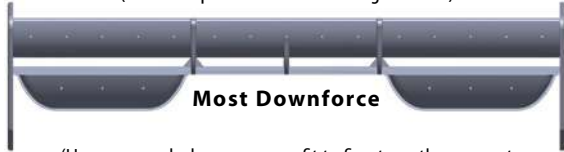

(Use as many holes as you see fit to fine tune the amount of downforce the wing creates.)

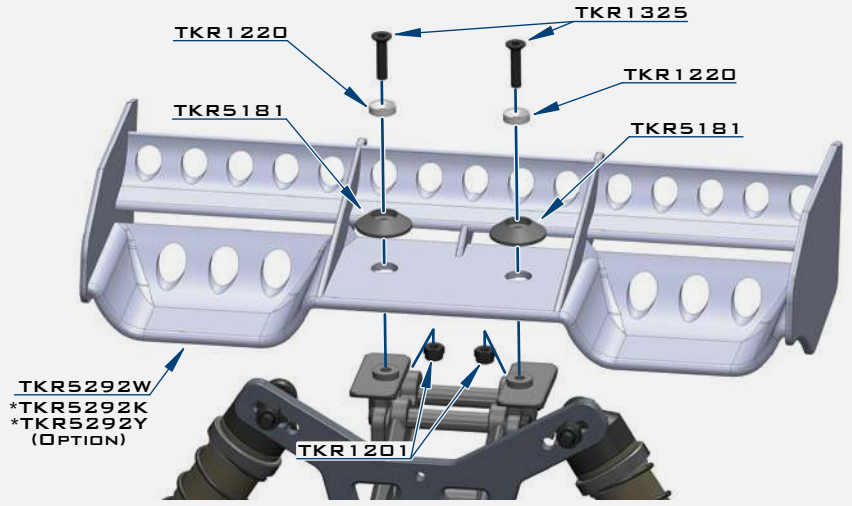

### STEP Q-2

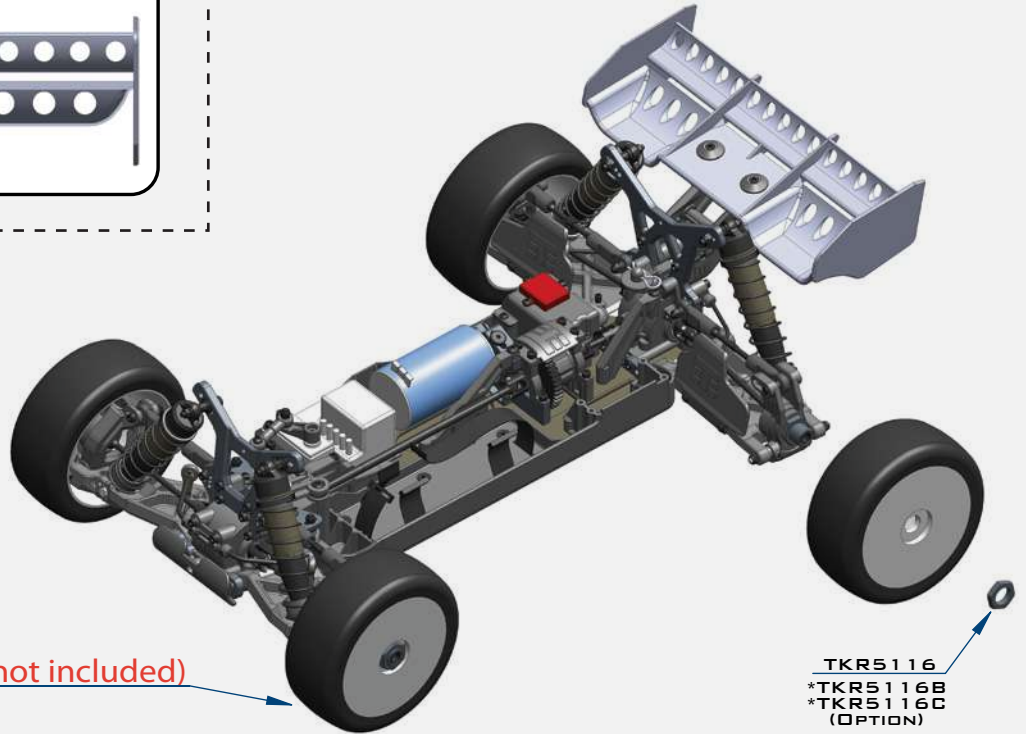

Note: It may be necessary to cut holes in the body for ventilation.

### STEP Q-3

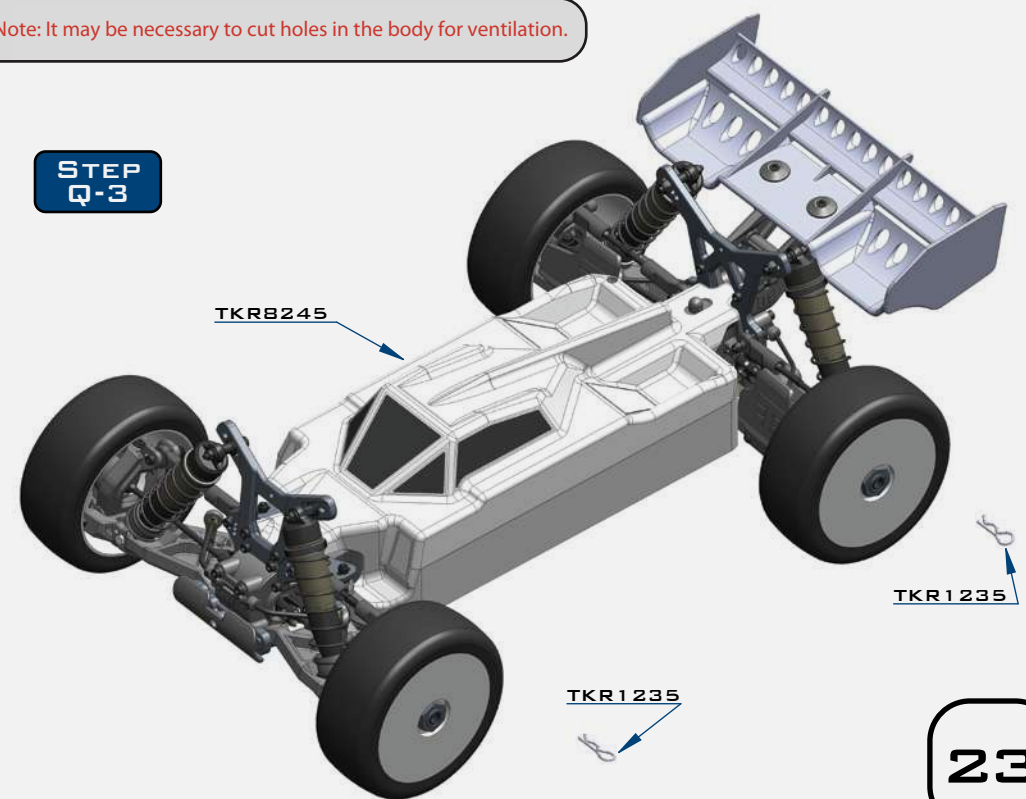

x2

TKR1201  
M3 LOCK NUT BLACK



x2

TKR1220  
M4 COUNTERSUNK WASHER

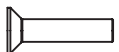

x2

TKR1325  
M3X14MM FLAT HEAD SCREW



x2

TKR1235  
BODY CLIP

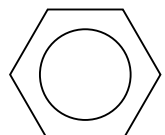

x4

TKR5116  
WHEEL NUT

# TKR8000 - EB48.41/8th Competition Electric Buggy Kit

## Parts List

TKR40007K – Battery Straps (EB48, black, 4 cell, 3pcs)  
TKR5010 – Battery Tray, Mud Guard (EB48, left side)  
TKR5011 – Radio Tray, Mud Guard (EB48, right side)  
TKR5012 – Gearbox (front)  
TKR5016B – Gearbox (rear, angled)  
TKR5020 – Hinge Pins (inner, front/rear)  
TKR5049A – Pivot Balls (6.8mm, no flng, sway bar, shck ends, almmn, 4pcs)  
TKR5050 – Turnbuckle (camber link, front/rear, 2pcs)  
TKR5053A – Pivot Balls (6.8mm, flanged, outside camber, aluminum, 4pcs)  
TKR5056 – Rod Ends (5.8mm, brake/steering/sway bar linkage, 8pcs)  
TKR5058A – Pivot Balls (5.8mm, no flange, brake/steering link, aluminum, 4pcs)  
TKR5060 – Steering Servo Brace (aluminum, gun metal ano)  
TKR5062 – Chassis Brace Set (front/rear/center)  
TKR5065 – ESC Tray and Radio/Battery Tray Accessories  
TKR5070 – Stub Axles (hardened steel, 2pcs)  
TKR5071 – Wheel Hubs (17mm, aluminum, gun metal ano, w/pins, 2pcs)  
TKR5075 – Diff Coupler (f/r, hardened steel)  
TKR5076 – Driveshaft (center, rear, hardened steel)  
TKR5079A – Stabilizer Balls (6.8mm, sway bars, aluminum, 4pcs)  
TKR5081 – Sway Bar (2.3mm, front)  
TKR5086 – Sway Bar Mounts  
TKR5101X – Servo Saver Spring (HD, EB48, SCT410, NB48)  
TKR5102A – Steering Posts (aluminum)  
TKR5103 – Servo Saver Post (aluminum, gun metal ano)  
TKR5116 – Wheel Nuts (17mm, serrated, gun metal ano, M12x1.0, 4pcs)  
TKR5122 – Steering Rack Bushings (aluminum, gun metal ano, 2pcs)  
TKR5123 – Turnbuckle (steering links, 2pcs)  
TKR5125 – O-Ring (ESC tray, 3pcs)  
TKR5126 – Antenna tube (universal, w/ caps, 5pcs)  
TKR5165 – V2 Hinge Pin Inserts, Wheelbase Shims (EB/NB/ET/NT/SCT)  
TKR5166 – Front Bumper (revised, EB/NB/ET/NT48)  
TKR5174 – Rear Arm Mud Guards (for TKR5184, EB/NB)  
TKR5181 – Low Profile Wing Mount and Body Mounts (EB/NB48/EB48SL)  
TKR5187 – Rod Ends (straight, 6.8mm, EB/NB/ET/NT48, 8pcs)  
TKR5191 – Tapered Driveshaft (EB48, ET48, center, front, 7075 aluminum, black ano)  
TKR5211X – Motor Mount Insert (aluminum, gun metal anodized, lightened)  
TKR5220 – Servo Horns (steering, brakes)  
TKR5230 – Steering linkage (M3x18mm threaded rod, 10pcs)  
TKR5231 – Servo Saver Nut and Spring  
TKR5260 – CNC Split Cntr Diff Mount (mtr mnt only, 7075, gun metal ano, EB/ET/SCT)  
TKR5263 – Split Cntr Diff Mount (composite, requires TKR5260, EB/ET/SCT/SL)  
TKR5268 – Shock Tower (front, 7075 CNC, gun metal ano, EB/NB48.3)  
TKR5269 – Shock Tower (rear, 7075 CNC, gun metal ano, EB/NB48.3)  
TKR5292W – Wing (high downforce, hole guides, white)  
TKR5491 – Sway Bar (2.4mm, rear)  
TKR5550 – Turnbuckle (camber link, front, 2pcs)  
TKR8006 – Chassis (7075, hard ano, EB48.4)  
TKR8027 – Shock Standoffs (fits TKR8702, TKR6018, TKR6003, 2pcs)  
TKR8034 – Hinge Pins (outer, f/r, EB/NB48.4)  
TKR8040A – Rear Hubs (L/R, 0 RC offset, EB/NB48.4)  
TKR8041 – Spindles (L/R, EB/NB48.4)  
TKR8042 – Kingpin Shoulder Screws (EB/NB48.4, 4pcs)  
TKR8052A – Pivot Balls (6.8mm, camber, str links, almmn, centered, 4pcs)  
TKR8087 – Universal Driveshaft Set (f/r, 96.5mm, EB/NB.4, 2 pcs)  
TKR8100 – Ackerman Plate (7075, EB/NB48.4)  
TKR8104 – Bell Cranks and Top Plates (ALL, requires TKR8100)  
TKR8161 – Hinge Pin Brace (CNC, 7075, EB/NB48.4, A Block)  
TKR8162 – Hinge Pin Brace (CNC, 7075, EB/NB48.4, B Block)  
TKR8163 – Hinge Pin Brace (CNC, 7075, EB/NB48.4, C Block)  
TKR8164 – Hinge Pin Brace (CNC, 7075, EB/NB48.4, D Block)  
TKR8184 – Suspension Arms (rear, EB/NB48.4)  
TKR8194A – Spindle Carriers (L/R, 15 degree, 0 RC offset, EB/NB.4)  
TKR8245 – Body (.040 lexan, EB48/48.3/48.4, SL, w/ window mask)  
TKR8286 – Suspension Arms (front, EB/NB48.4)

## Differential List

TKR5113 – Differential Case (f/c/r)  
TKR5114XB – Differential Outdrives (f/r, lightened, revised)  
TKR5143 – Differential Seals (3pcs)  
TKR5144 – Differential O-Rings (6pcs)  
TKR5145B – Differential Shims (revised, 6x17mm, 6pcs)  
TKR5149 – Differential Cross Pins (steel, 6pcs)  
TKR5150 – Differential Gear Set (internal gears only)  
TKR5237K – Spur Gear (44t, black, composite)  
TKR8151 – Differential Ring Gear (CNC, 40t, use with TKR8152)  
TKR8152 – Diff Pinion (12t, CNC, use with TKR8151)

## Shocks List

TKR6007 – Shock Cap Bushings (4pcs, EB/NB/ET/NT/SCT)  
TKR6009 – Shock O-Ring and Bladder Set (for 2 shocks)  
TKR6013 – Shock Adjustment Nuts (aluminum, gun metal ano, 2pcs)  
TKR6015 – Shock Cartridge Caps (aluminum, gun metal ano, 2pcs)  
TKR6016 – Shock Body (rear, aluminum, hard ano, 2pcs)  
TKR6017 – Shock Shafts (rear, steel, 2pcs)  
TKR6060 – Shock Body (rear, x-long, aluminum, hard ano, 2pcs)  
TKR6061 – Shock Shafts (rear, x-long, steel, 2pcs)  
TKR6140B – Locking Shock Rod End and Spring Perch Set (revised, EB/NB/ET/NT/SCT)  
TKR6144 – Shock Boots (long length, EB/NB, 2pcs)  
TKR6145 – Shock Boots (X-long length, rear EB/NB, 2pcs)  
TKR6146B – Shock Cartridge Set (revised, CNC, Delrin, EB/NB/ET/NT/SCT)  
TKR6165 – Shock Pistons (CNC, flat/flat, 4x1.9, 11.3mm2)  
TKR8702 – Shock Caps (7075, emulsion/vented/standard, black ano, 2pcs)  
TKR8725 – Emulsion O-ring Set (4x cap seals, 8x emulsion o-rings, for 16mm shocks)  
TKR8763 – Shock Spring Set (front, 1.6x11.6, 3.58lb/in, 75mm, black)  
TKR8773 – Shock Spring Set (rear, 1.6x14.5, 2.75lb/in, 85mm, orange)

## Bearings List

TKRBB050825 – Ball Bearing (5x8x2.5mm, 4pcs)  
TKRBB05104 – Ball Bearing (5x10x4, 4pcs)  
TKRBB05114 – Ball Bearing (5x11x4, 4pcs)  
TKRBB05134 – Ball Bearing (5x13x4, 4pcs)  
TKRBB06103 – Ball Bearing (6x10x3, 4pcs)  
TKRBB08165 – Ball Bearing (8x16x5, 4pcs)  
TKRBB13194 – Ball Bearing (13x19x4, 4pcs)

## Hardware List

TKR1200 – M2.5 Locknuts (zinc finish, 10pcs)  
TKR1201 – M3 Locknuts (black, 10pcs)  
TKR1202 – M4 Locknuts (black, 10pcs)  
TKR1211 – M3 Locknuts (flanged, black, 10pcs)  
TKR1220 – M3 Countersunk Washers (aluminum, natural, 10pcs)  
TKR1221 – M3x8mm Washer (black, 10pcs)  
TKR1222 – 13x16x.1mm Diff Shims (10pcs)  
TKR1226 – 5x7x.2mm shims (10pcs)  
TKR1228 – M4 Countersunk Washer (black, 10pcs)  
TKR1235 – Body Clips (10pcs)  
TKR1238 – Droop Adjustment Screws (M4x10mm, 8pcs)  
TKR1240 – Lower Shock Mount Screws (2 CW thread, 2 CCW thread, EB/NB/SCT)  
TKR1248 – M2x4mm Cap Head Screws (black, 10pcs)  
TKR1250 – Steering Link Screws (black, steel, 2pcs)  
TKR1322 – M3x8mm Flat Head Screws (black, 10pcs)  
TKR1323 – M3x10mm Flat Head Screws (black, 10pcs)  
TKR1325 – M3x14mm Flat Head Screws (black, 10pcs)  
TKR1341 – M4x6mm Flat Head Screws (black, 10pcs)  
TKR1343 – M4x10mm Flat Head Screws (black, 10pcs)  
TKR1344 – M4x12mm Flat Head Screws (black, 10pcs)  
TKR1346 – M4x15mm Flat Head Screws (black, 10pcs)  
TKR1401 – M3x6mm Button Head Screws (black, 10pcs)  
TKR1402 – M3x8mm Button Head Screws (black, 10pcs)  
TKR1403 – M3x10mm Button Head Screws (black, 10pcs)  
TKR1407 – M3x16mm Button Head Screws (black, 10pcs)  
TKR1443 – M4x10mm Button Head Screws (black, 10pcs)  
TKR1522 – M3x8mm Cap Head Screws (black, 10pcs)  
TKR1524 – M3x12mm Cap Head Screws (black, 10pcs)  
TKR1525 – M3x14mm Cap Head Screws (black, 10pcs)  
TKR1529 – M3x20mm Cap Head Screws (black, 10pcs)  
TKR1533 – M3x40mm Cap Head Screws (black, 10pcs)  
TKR1534 – M3x22mm Cap Head Screws (black, 10pcs)  
TKR1601 – M3x4mm Set Screws (black, 10pcs)  
TKR1603 – M5x4mm Set Screws (black, 10pcs)  
TKR1605 – M3x10mm Set Screws (black, 10pcs)

## Option Parts

TKR1103 – Turnbuckle Wrench (4mm, 5mm, hardened steel)  
TKR1104 – XT Hex Wrench (1.5mm, adjustable length, 4mm shank)  
TKR1105 – XT Hex Wrench (2.0mm, adjustable length, 4mm shank)  
TKR1106 – XT Hex Wrench (2.5mm, adjustable length, 4mm shank)  
TKR1107 – XT Nut Driver (5.0mm, adjustable length, 4mm shank)  
TKR1108 – XT Nut Driver (5.5mm, adjustable length, 4mm shank)  
TKR1115 – Pivot Ball and Shock Multi-tool (aluminum)  
TKR1116 – 17mm Wheel Wrench, Shock Cap Tool  
TKR1119 – 5.5mm / 7.0mm Wrench (hardened steel)  
TKR5060C – Steering Servo Brace (carbon fiber)  
TKR5071B – Wheel Hubs (17mm, alum, ltnd, gun metal ano, 1mm off, w/pins, 2pcs)  
TKR5071C – Wheel Hubs (17mm, alum, ltnd, gun metal ano, 2mm off, w/pins, 2pcs)  
TKR5071X – Wheel Hubs (aluminum, lightened, gun metal ano, w/pins, 2pcs)  
TKR5080 – Sway Bar (front, 2.2mm)  
TKR5082 – Sway Bar (front, 2.4mm)  
TKR5083 – Sway Bar (front, 2.5mm)  
TKR5084 – Sway Bar (front, 2.6mm)  
TKR5085 – Sway Bar (front, 2.8mm)  
TKR5087 – Sway Bar (front, 3.0mm)  
TKR5092 – Sway Bar (front, 2.0mm, EB.3/NB.3/SL/SCT.3)  
TKR5093 – Sway Bar (front, 2.1mm, EB.3/NB.3/SL/SCT.3)  
TKR5094 – Sway Bar (front, 2.7mm, EB.3/NB.3/SL/SCT.3)  
TKR5095 – Sway Bar (front, 2.9mm, EB.3/NB.3/SL/SCT.3)  
TKR5149A – Diff Cross Pins (aluminum, 6pcs, requires TKR5150)  
TKR5237 – Spur Gear (44t, composite, natural color)  
TKR5251B – Aluminum Servo Horn (23t spline, M3 clamp, double hole arm)  
TKR5252B – Aluminum Servo Horn (24t spline, M3 clamp, double hole arm)  
TKR5253B – Aluminum Servo Horn (25t spline, M3 clamp, double hole arm)  
TKR5262 – CNC Split Cntr Diff Mount (diff mounts only, 7075, gun metal ano, EB/ET/SCT)  
TKR5292K – Wing (high down force, hole guides, ROAR/IFMAR legal, black)  
TKR5292Y – Wing (high down force, hole guides, ROAR/IFMAR legal, yellow)  
TKR5490 – Sway Bar (rear, 2.3mm)  
TKR5492 – Sway Bar (rear, 2.5mm)  
TKR5493 – Sway Bar (rear, 2.6mm)  
TKR5494 – Sway Bar (rear, 2.8mm)  
TKR5495 – Sway Bar (rear, 3.0mm)  
TKR5496 – Sway Bar (rear, 2.1mm, EB.3/NB.3/SL/SCT.3, ET48, NT48)  
TKR5497 – Sway Bar (rear, 2.2mm, EB.3/NB.3/SL/SCT.3, ET48, NT48)  
TKR5498 – Sway Bar (rear, 2.7mm, EB.3/NB.3/SL/SCT.3, ET48, NT48)  
TKR5499 – Sway Bar (rear, 2.9mm, EB.3/NB.3/SL/SCT.3, ET48, NT48)  
TKR6003 – Shock Caps (aluminum, gun metal ano, 2pcs, EB48)  
TKR6003B – Shock Caps (aluminum, non-vented top, 2pcs)  
TKR6009B – Shock O-Ring Set (16pcs)  
TKR6017T – Shock Shafts w/ TiNi coating (rear, steel, 2pcs)  
TKR6061T – Shock Shafts w/ TiNi coating (rear, x-long, steel, 2pcs)  
TKR6152 – Full Option Shock Kit (122mm, no springs, no pistons)  
TKR6153 – Full Option Shock Kit (137mm, no springs, no pistons)  
TKR6159 – Shock Pistons (CNC, flat/tapered, 4x1.8mm)  
TKR6160 – Shock Piston Blanks (CNC, flat/tapered, 16 dimples)  
TKR6162 – Shock Pistons (CNC, flat/tapered, 3x2.1, 10.4mm2, 4pcs)  
TKR6163 – Shock Piston Blanks (CNC, flat/flat, 16 dimples)



Name: Box Stock Date: \_\_\_\_\_ Event: \_\_\_\_\_

Track: Indoor  Outdoor  Size: Small  Medium  Large  Traction: Low  Med  High

Surface: Smooth  Bumpy  Rutted  Type: Loose/Loamy  Hard Pack  Blue Groove  Clay

Bumpsteer/Ackerman/Servo Saver/Steering Stop: \_\_\_\_\_ Condition: Dusty  Dry  Wet  Muddy

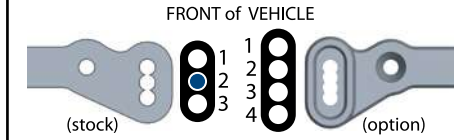

### Shocks:

	FRONT	REAR
OIL	550	450
BRAND		
PISTON	4x 1.9 flat	4x 1.9 flat
SPRING	black	orange
REBOUND	0 %	0 %
STD/EMUL/VENT	emul	emul

NOTES:

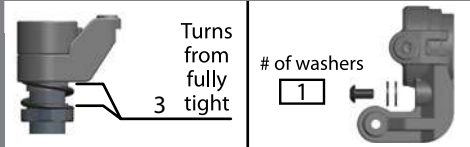
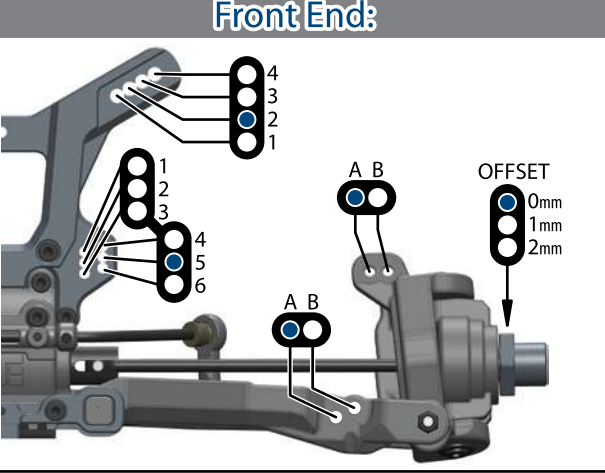

### Tires / Wheels:

	FRONT	REAR
BRAND/TREAD		
COMPOUND		
INSERT		
WHEEL		

NOTES:

### Suspension:

	FRONT	REAR
RIDE HEIGHT	27	29
CAMBER	-2 deg	-2 deg
CASTER	15 deg	
SWEEP	0 deg	
KICK UP	12 deg	
ANTI-SQUAT		2 deg
TOE (in/out)	.5 deg out	2.5 deg
SWAY BAR	2.3mm	2.4mm
SHOCK LENGTH (DROOP)	120	135



### Differential Oil:

FRONT	CENTER	REAR
10k	10k	7k

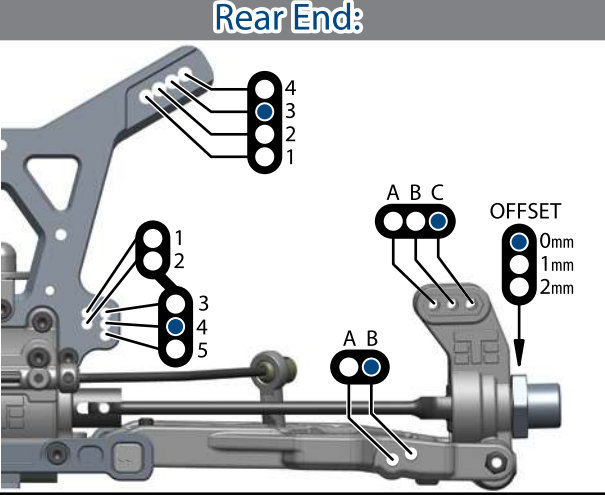

### Body/Wing:

BODY MAKE	stock
WING MAKE	stock

### Electronics:

ESC:	
BATTERY:	
MOTOR:	
RADIO:	
SERVO:	300oz/in min

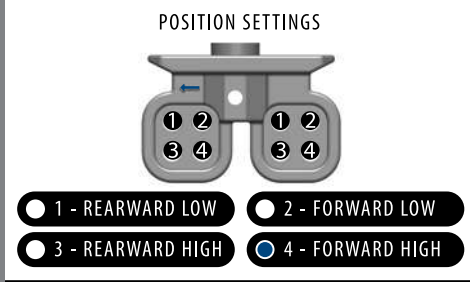

### Drivetrain:

PINION SIZE		(teeth)
-------------	--	---------

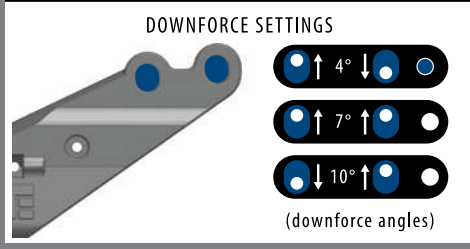
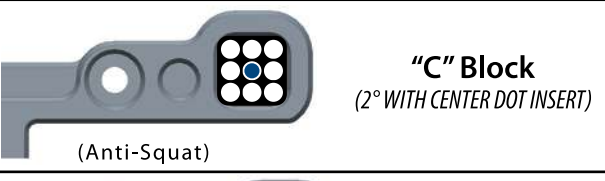

### Chassis Braces:

Front  Middle  Rear

(front brace is always recommended)

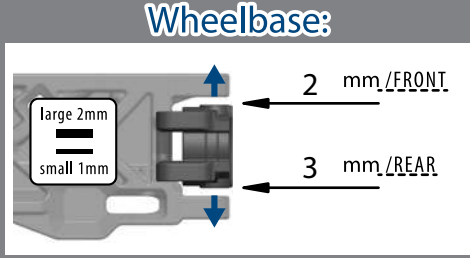

### Notes:





Name: \_\_\_\_\_ Date: \_\_\_\_\_ Event: \_\_\_\_\_

Track: Indoor  Outdoor  Size: Small  Medium  Large  Traction: Low  Med  High

Surface: Smooth  Bumpy  Rutted  Type: Loose/Loamy  Hard Pack  Blue Groove  Clay

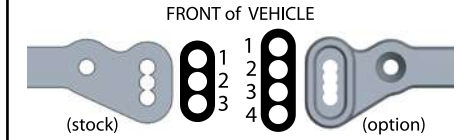
Bumpsteer/Ackerman/Servo Saver/Steering Stop: \_\_\_\_\_ Condition: Dusty  Dry  Wet  Muddy



### Shocks:

	FRONT	REAR
OIL		
BRAND		
PISTON		
SPRING		
REBOUND	%	%
STD/EMUL/VENT		
NOTES:		

### Front End:

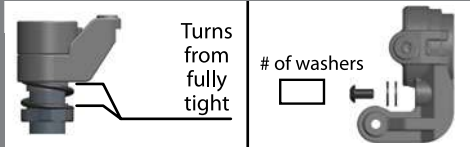
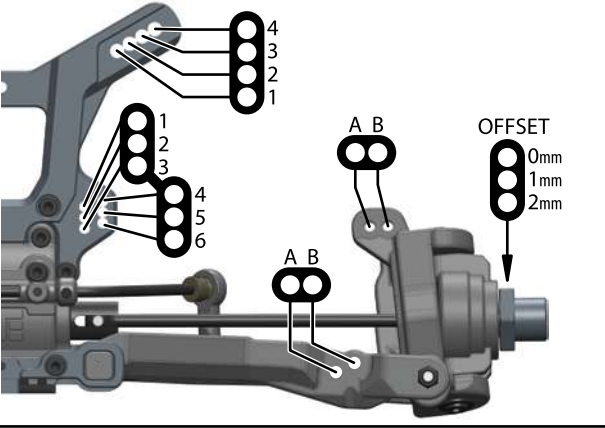

### Suspension:

	FRONT	REAR
RIDE HEIGHT		
CAMBER		
CASTER		
SWEEP		
KICK UP		
ANTI-SQUAT		
TOE (in/out)		
SWAY BAR		
SHOCK LENGTH (DROOP)		

### Tires / Wheels:

	FRONT	REAR
BRAND/TREAD		
COMPOUND		
INSERT		
WHEEL		
NOTES:		

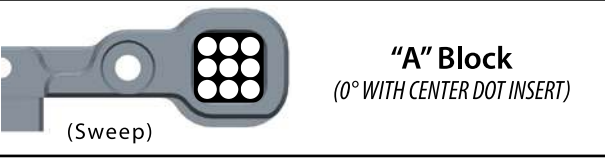

### Differential Oil:

	FRONT	CENTER	REAR

### Rear End:

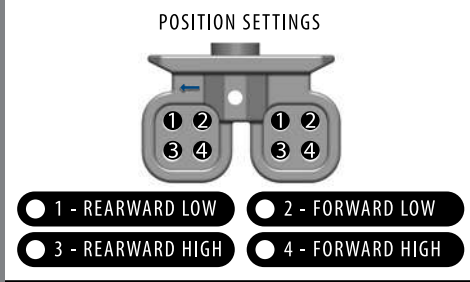
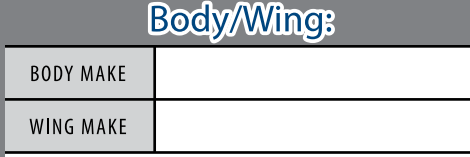
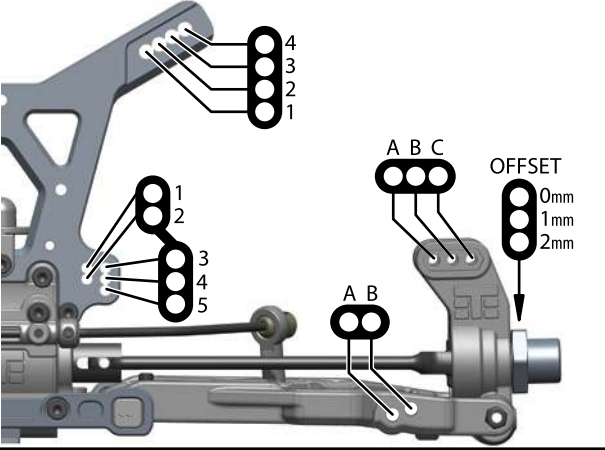

### Electronics:

ESC:	
BATTERY:	
MOTOR:	
RADIO:	
SERVO:	

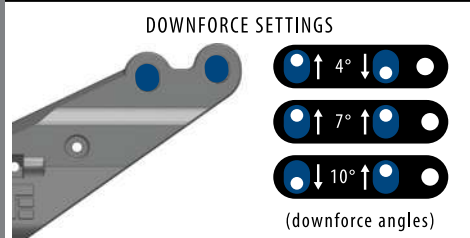

### Drivetrain:

PINION SIZE		(teeth)
-------------	--	---------

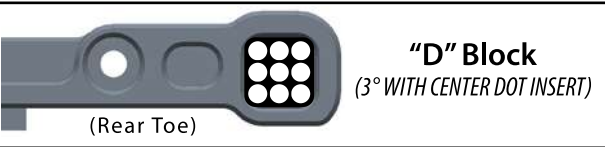
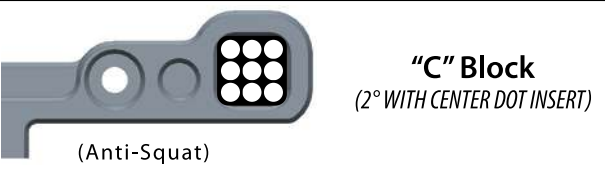

### Chassis Braces:

Front	<input type="radio"/>	Middle	<input type="radio"/>	Rear	<input type="radio"/>
(front brace is always recommended)					

### Wheelbase:

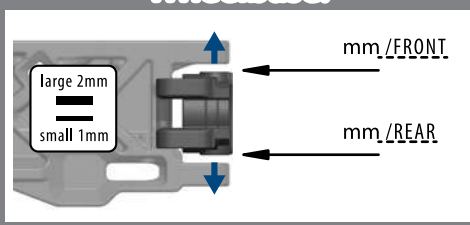

### Notes:





Name: \_\_\_\_\_ Date: \_\_\_\_\_ Event: \_\_\_\_\_

Track: Indoor  Outdoor  Size: Small  Medium  Large  Traction: Low  Med  High

Surface: Smooth  Bumpy  Rutted  Type: Loose/Loamy  Hard Pack  Blue Groove  Clay

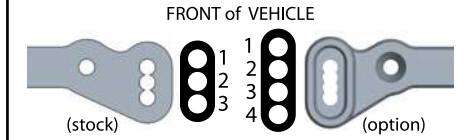
Bumpsteer/Ackerman/Servo Saver/Steering Stop: \_\_\_\_\_ Condition: Dusty  Dry  Wet  Muddy



### Shocks:

	FRONT	REAR
OIL		
BRAND		
PISTON		
SPRING		
REBOUND	%	%
STD/EMUL/VENT		
NOTES:		

### Front End:

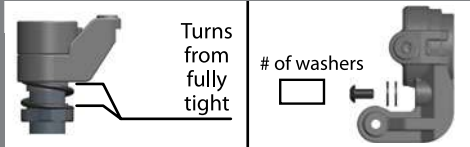
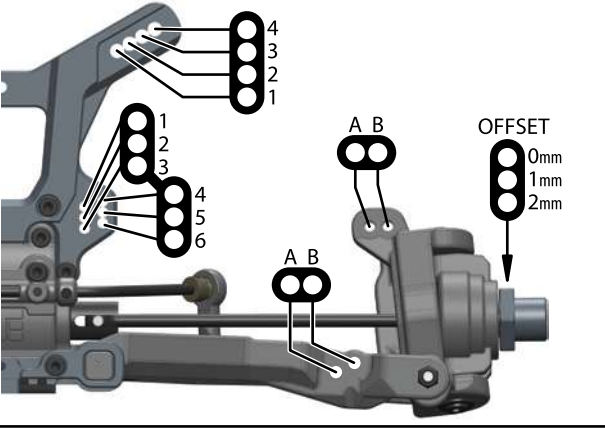

### Suspension:

	FRONT	REAR
RIDE HEIGHT		
CAMBER		
CASTER		
SWEEP		
KICK UP		
ANTI-SQUAT		
TOE (in/out)		
SWAY BAR		
SHOCK LENGTH (DROOP)		

### Tires / Wheels:

	FRONT	REAR
BRAND/TREAD		
COMPOUND		
INSERT		
WHEEL		
NOTES:		

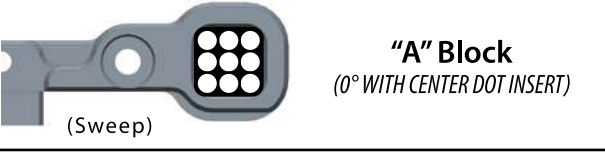

### Differential Oil:

	FRONT	CENTER	REAR

### Rear End:

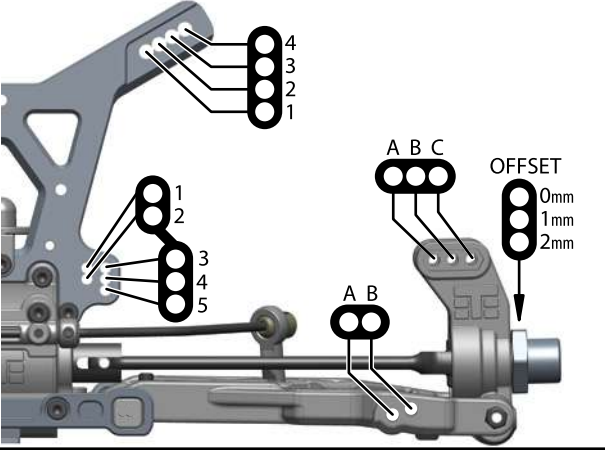

### POSITION SETTINGS

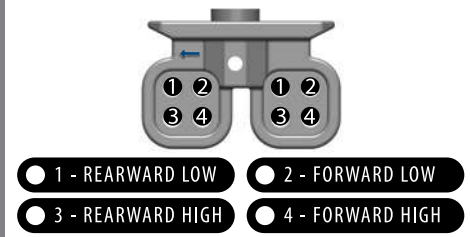

### DOWNFORCE SETTINGS

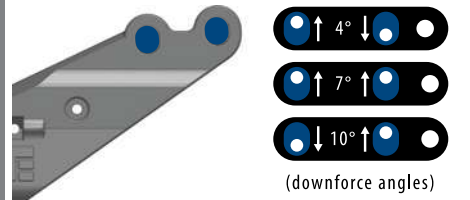

### Electronics:

ESC:	
BATTERY:	
MOTOR:	
RADIO:	
SERVO:	



### Drivetrain:

PINION SIZE		(teeth)
-------------	--	---------

### Chassis Braces:

Front <input type="radio"/>	Middle <input type="radio"/>	Rear <input type="radio"/>
(front brace is always recommended)		

### Wheelbase:

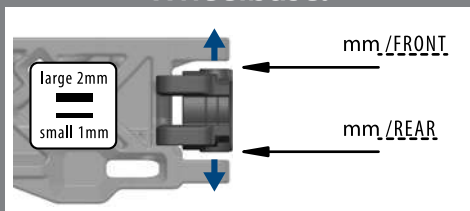

### Notes:





Tekno RC  
10755 Scripps Poway Pkwy #598  
San Diego CA 92131  
USA

[www.teknorc.com](http://www.teknorc.com)

