

Tekno RC RX/Battery Box and Fuel Tank Conversion for REVO

****PLEASE READ AND FOLLOW INSTRUCTIONS CAREFULLY TO ENSURE PROPER INSTALLATION - USE MEDIUM THREAD LOCKING COMPOUND WHERE INDICATED****

What you'll need for installation: Drill, 1/16" drill bit, 7/64" drill bit, thread locking compound, the tools that came with your REVO (or equivalent). If you are running the **stock tank** you will also need Traxxas part #5376 (see Fig. 3).

1. Decide which tank and RX box configuration you will be running - Below is a configuration matrix outlining what tanks go with each configuration. A diagram of the inside of the battery box top with mounting location information follows.

| Tank | Stock Config | Alt. Config | Mounting locations | Small Bracket | Large Bracket |
|-------------|--------------|-------------|----------------------|---------------|---------------|
| TRAS363 | X | - | G (tank), A & E (RX) | - | - |
| TRAS363 | - | X | G | - | - |
| OFNA 19504 | - | X | B | front | rear |
| OFNA 19076 | - | X | C | rear | - |
| OFNA 18047 | - | X | F | - | - |
| OFNA 18047 | X | - | F (tank), A & E (RX) | - | - |
| Mugen ED812 | - | X | C | - | - |
| Mugen C0853 | - | X | D | - | - |

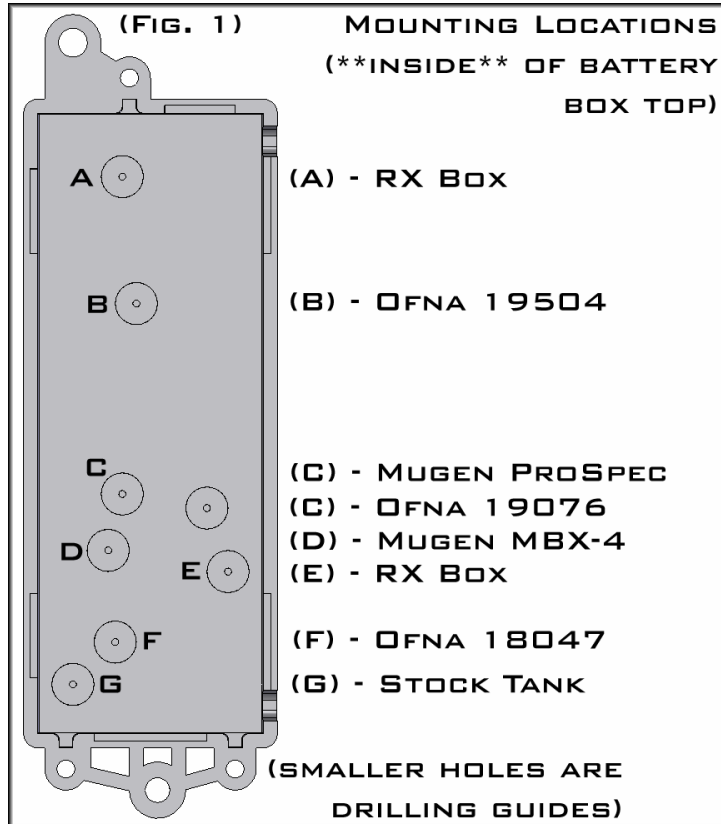

2. Remove stock Fuel Tank and RX/Battery box - If you are going to run the stock tank, leave the rear tank mounting post installed on the truck and set the tank aside. If you will be running a non-stock tank, remove the rear tank mount post as part of this step.

3. Install the Tekno RC Battery Box top - Note the two screws needing medium thread locking compound as shown in the diagram (Fig. 2, above, right).

Questions? Email us at support@teknorc.com or visit us at www.teknorc.com.

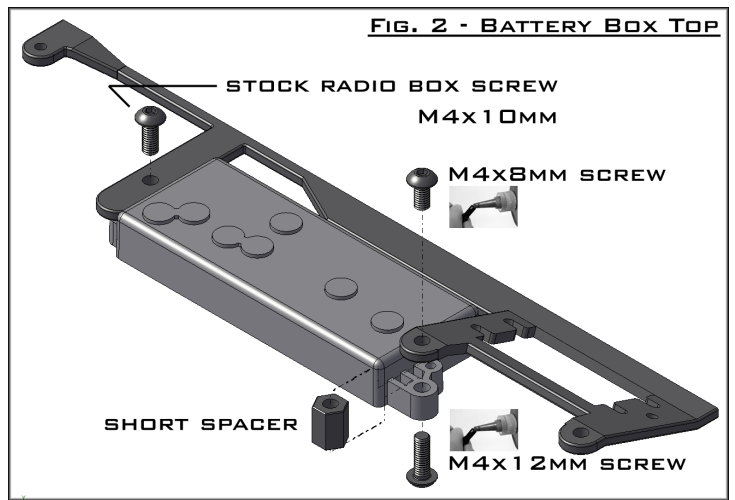

4. Drill required holes (READ CAREFULLY, we can't be held responsible for improperly drilled holes) - With the top of the battery box mounted, turn your REVO upside down. Locate the holes you will need to drill according to your chosen configuration. Using the molded in drill guides for centering, carefully drill each required hole with the 1/16" drill bit first. Then use the 7/64" drill bit to carefully drill each hole again. This process will ensure that the holes are centered and drilled out to the proper diameter for the screws to fit.

5. Mount the RX box and tank mount posts
Stock Configuration - You should have drilled 3 holes for the stock RX box configuration. Thread the supplied M3x10mm screws into each hole. These screws will fasten the tank mount post and the RX box to the battery box top as shown below (Fig. 3). Do not overtighten the screws, you want them to be snug without stripping the mounting post or the RX box mounting holes. There is a little stub on the bottom of the stock post that needs to be ground down in order for the tank mount post to sit flush with the battery box.

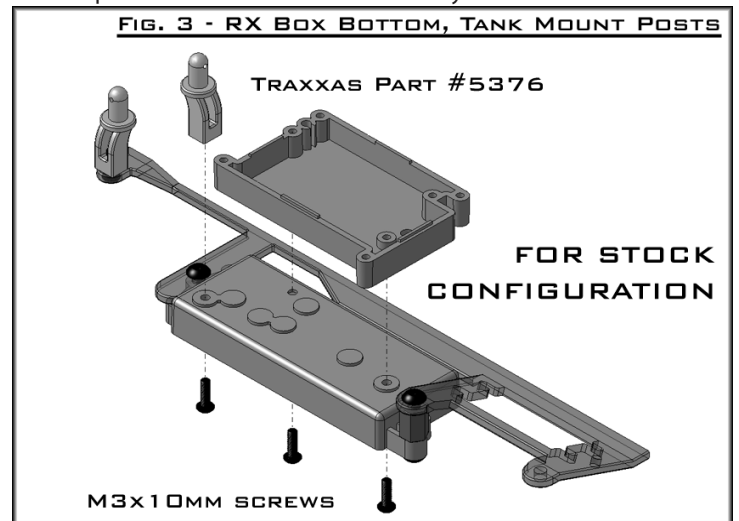

Alternate Configuration - You should have drilled 1 hole for the alternate configuration. This single hole is for the tank mount post. The hole location will vary depending on the tank you choose, but we will use the OFNA 19504 location for the instruction diagrams (Fig. 4, over, top left). Tighten the aluminum tank mounting posts to the chassis and the battery box top. Note that these 2 screws need medium thread locking compound. Next, secure the RX box bottom to the chassis, being careful not to overtighten the screws.

6. Apply tape to RX and Battery box - The white double sided tape is used to fasten the receiver to the bottom of the RX box. Peel off one side and apply it to the bottom of your receiver.

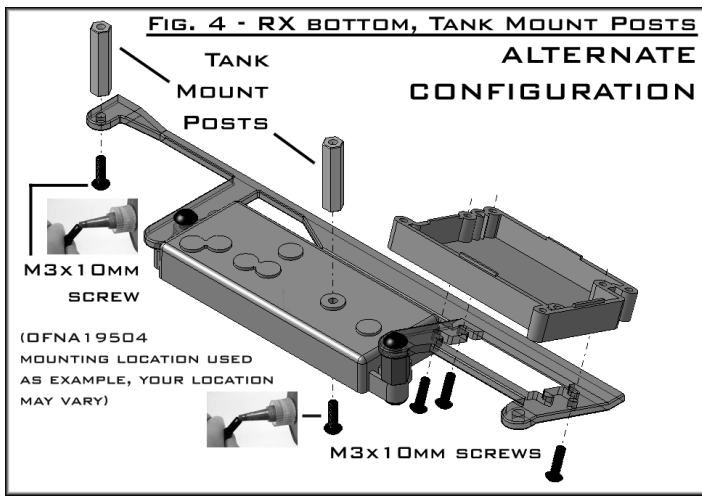

Set the receiver aside. The 3 strips of black tape are used for cushioning the battery. Apply the two thin strips to the (over) grooves in the bottom of the battery box cover. Apply the thicker strip to the middle of the inside of the battery box top.

7. Install battery and battery box cover - With your REVO upside down, place the battery in the battery box top and route the battery lead through the front slot in the box. Using the supplied M3x10mm screws, secure the battery box cover to the battery box top as shown in the figure below (Fig. 5).

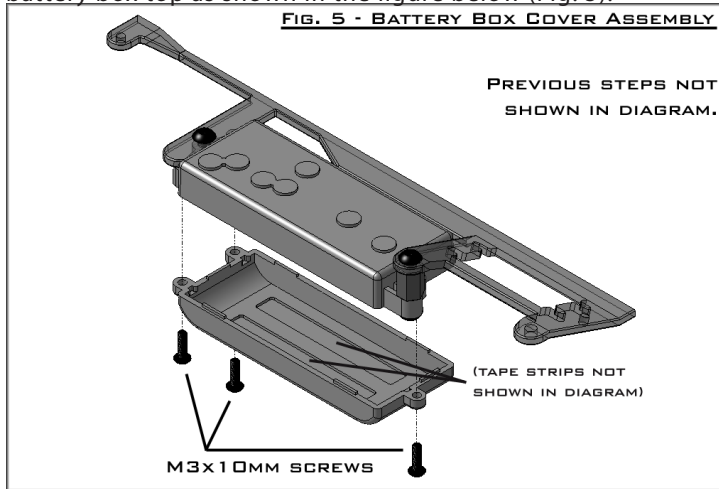

8. Install antenna tube and receiver - Thread your receiver's antenna through the antenna tube (this may already be done). Insert the antenna tube into the integrated antenna tube mount as shown in the diagram (Fig. 6 - above right).

Pull the antenna through the tube until the receiver sits inside the RX box (about 3/4" between the receiver and the tube). Once you have the receiver where you want it, twist it up slightly and pull off the other side of the mounting tape, exposing the adhesive. Carefully press the receiver back down, fastening it to the RX box.

9. Mount the receiver switch, plug in electronics and secure the RX box top - There is a cutout in the RX box top to mount the stock switch harness (most standard switch harnesses will also fit). Using a couple 2x8mm screws (not supplied) mount the switch to the RX box top.

Next, plug your servo, battery and switch harness leads into the receiver. Make sure you plug them in correctly. Some people like to use a couple small zip ties to tidy up the servo leads. **For easier battery charging**, you may want to route the red charging lead out one of the holes in the RX box top.

Before securing the RX box top, check to make sure your radio and servos are functioning properly. If everything checks out, secure the RX box top with the supplied M3x6mm screws as shown in the diagram (Fig. 6, right). Doublecheck to make sure the box top is seated correctly and that all of

your servo leads are routed properly and aren't being pinched by the RX box top.

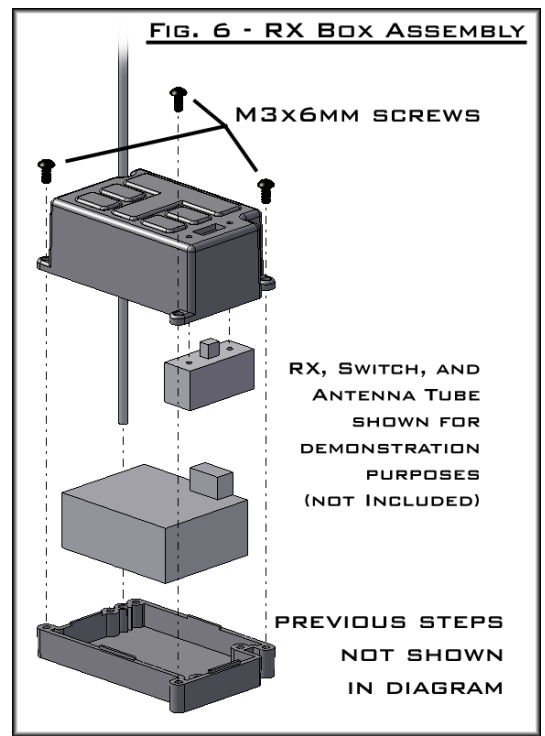

10. Mount the fuel tank

Stock Tank - If you are running the stock tank, you will need Traxxas part# 5376 for the extra tank mount. Reconnect your fuel lines (or replace them), mount the body, and you're all done!

Non-stock tank - If you're using a non-stock tank, the tank mounting holes should line up with the aluminum mounting posts that you previously installed. Some tanks, such as the 250cc tank, require the use of the supplied mounting brackets. Check the configuration matrix (over, top left) for your tank's requirements. The diagram below shows the proper o-ring, washer, and bracket assembly order for both cases (with brackets, or without brackets). Note the use of medium thread locking compound on all metal to metal connections here. Tighten down the screws enough to compress the o-rings about half way, but do not overtighten.



Body modification - Most of the non-stock tanks will require you to cut out a new fuel filler hole. Make sure it is big enough for the fuel lid to open/close properly. If you're running the stock body and the 250cc tank, minor body trimming around the existing fuel filler hole is recommended for a better fit.

Note - The mounting hardware in the kit will allow you to mount many other tanks that aren't listed here.